



(19) **United States**

(12) **Patent Application Publication**  
**Grigoryan et al.**

(10) **Pub. No.: US 2021/0303431 A1**

(43) **Pub. Date: Sep. 30, 2021**

(54) **METHODS AND SYSTEMS THAT IDENTIFY DIMENSIONS RELATED TO ANOMALIES IN SYSTEM COMPONENTS OF DISTRIBUTED COMPUTER SYSTEMS USING CLUSTERED TRACES, METRICS, AND COMPONENT-ASSOCIATED ATTRIBUTE VALUES**

(52) **U.S. Cl.**  
CPC ..... **G06F 11/3006** (2013.01); **G06F 11/3075** (2013.01); **G06F 11/3476** (2013.01); **G06F 11/323** (2013.01)

(57) **ABSTRACT**

(71) Applicant: **VMware, Inc.**, Palo Alto, CA (US)

(72) Inventors: **Naira Movses Grigoryan**, Yerevan (AM); **Arnak Poghosyan**, Yerevan (AM); **Ashot Nshan Harutyunyan**, Yerevan (AM); **Clement Pang**, Palo Alto, CA (US); **Dev Nag**, Palo Alto, CA (US)

(73) Assignee: **VMware, Inc.**, Palo Alto, CA (US)

(21) Appl. No.: **17/119,462**

(22) Filed: **Dec. 11, 2020**

**Related U.S. Application Data**

(63) Continuation-in-part of application No. 16/833,102, filed on Mar. 27, 2020.

**Publication Classification**

(51) **Int. Cl.**  
**G06F 11/30** (2006.01)  
**G06F 11/32** (2006.01)  
**G06F 11/34** (2006.01)

The current document is directed to methods and systems that employ distributed-computer-system metrics collected by one or more distributed-computer-system metrics-collection services, call traces collected by one or more call-trace services, and attribute values for distributed-computer-system components to identify attribute dimensions related to anomalous behavior of distributed-computer-system components. In a described implementation, nodes correspond to particular types of system components and node instances are individual components of the component type corresponding to a node. Node instances are associated with attribute values and node are associated with attribute-value spaces defined by attribute dimensions. A set of call traces is partitioned, by clustering. Using attribute values and call traces, attribute dimensions that are likely related to particular anomalous behaviors of distributed-computer-system components are determined by decision-tree-related analyses for each partition and are reported to one or more computational entities to facilitate resolution of the anomalous behaviors.

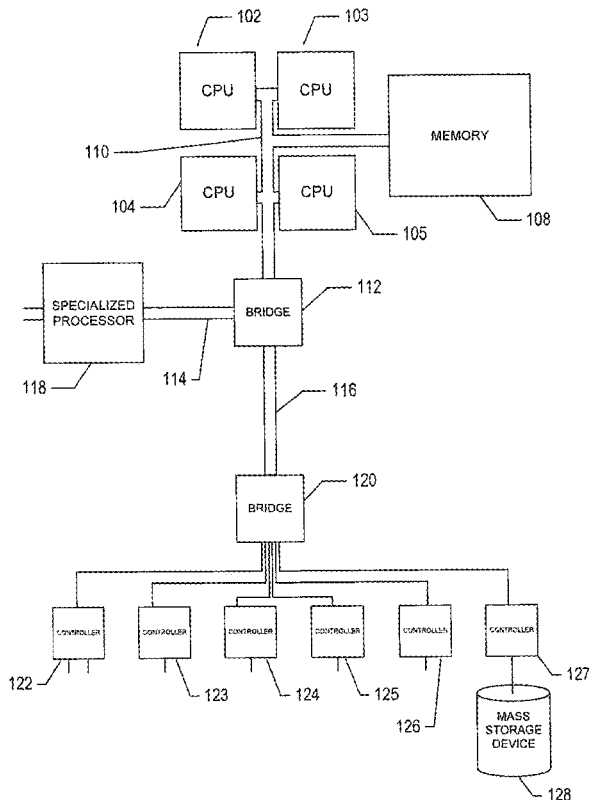

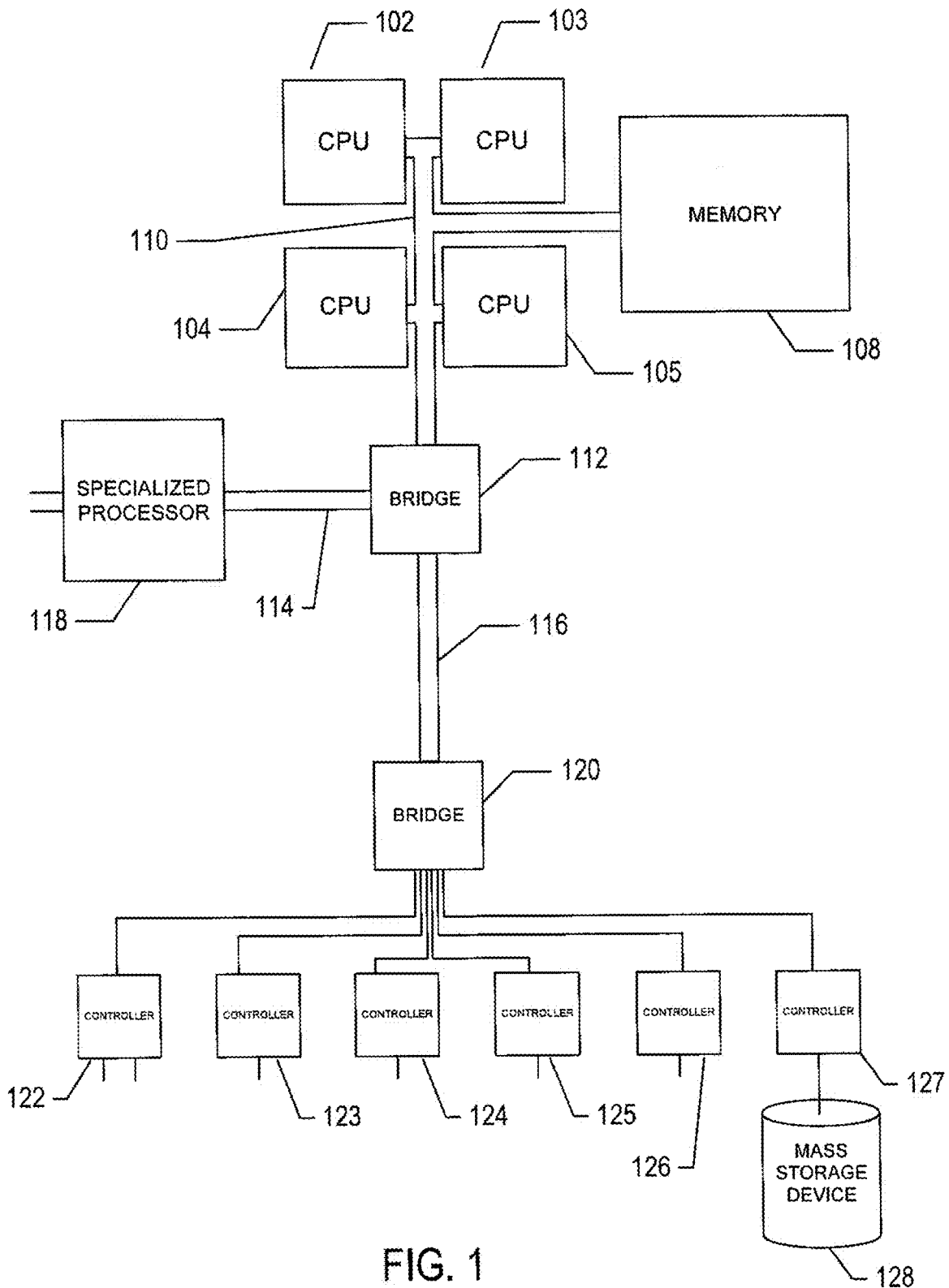

FIG. 1

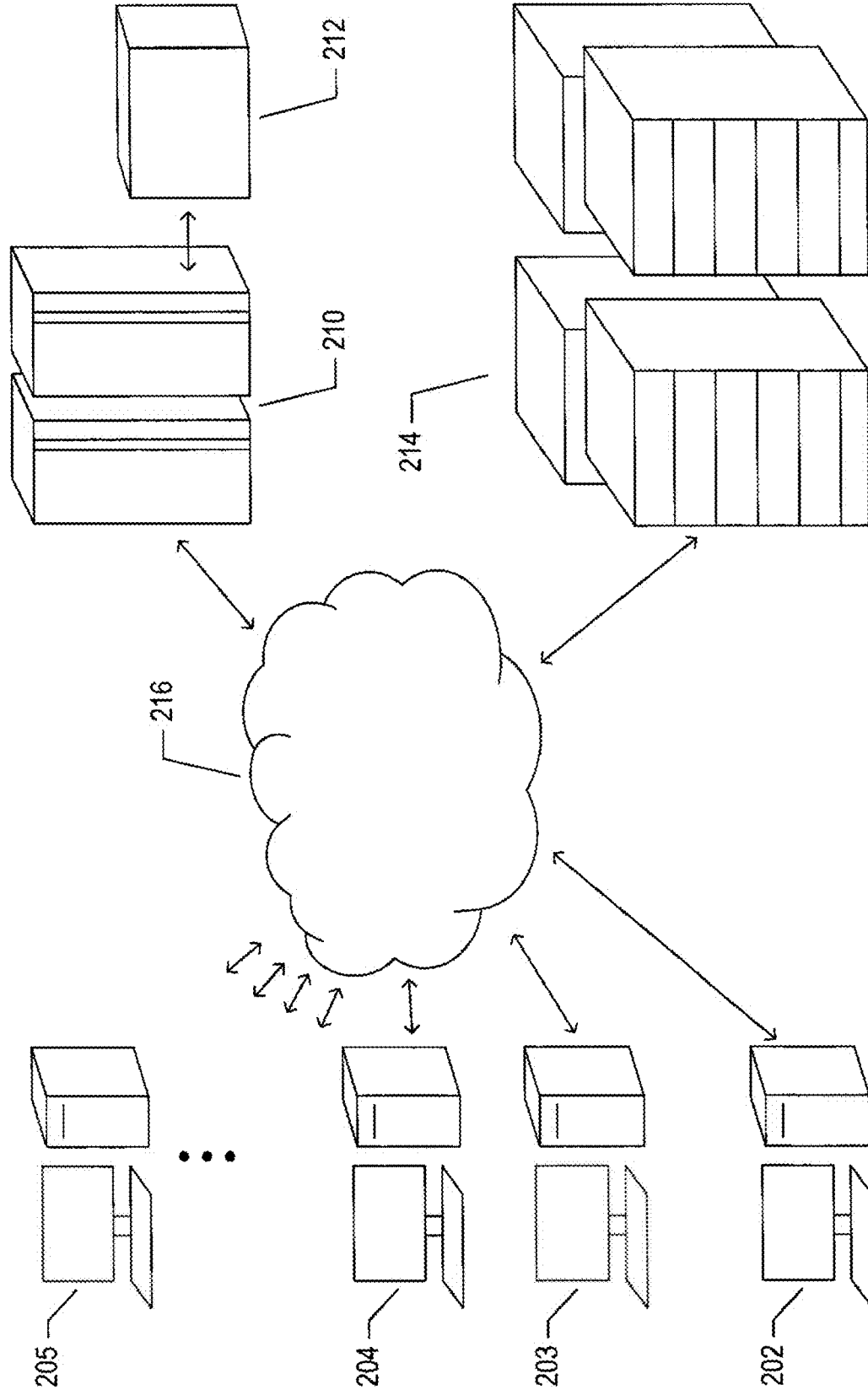

FIG. 2

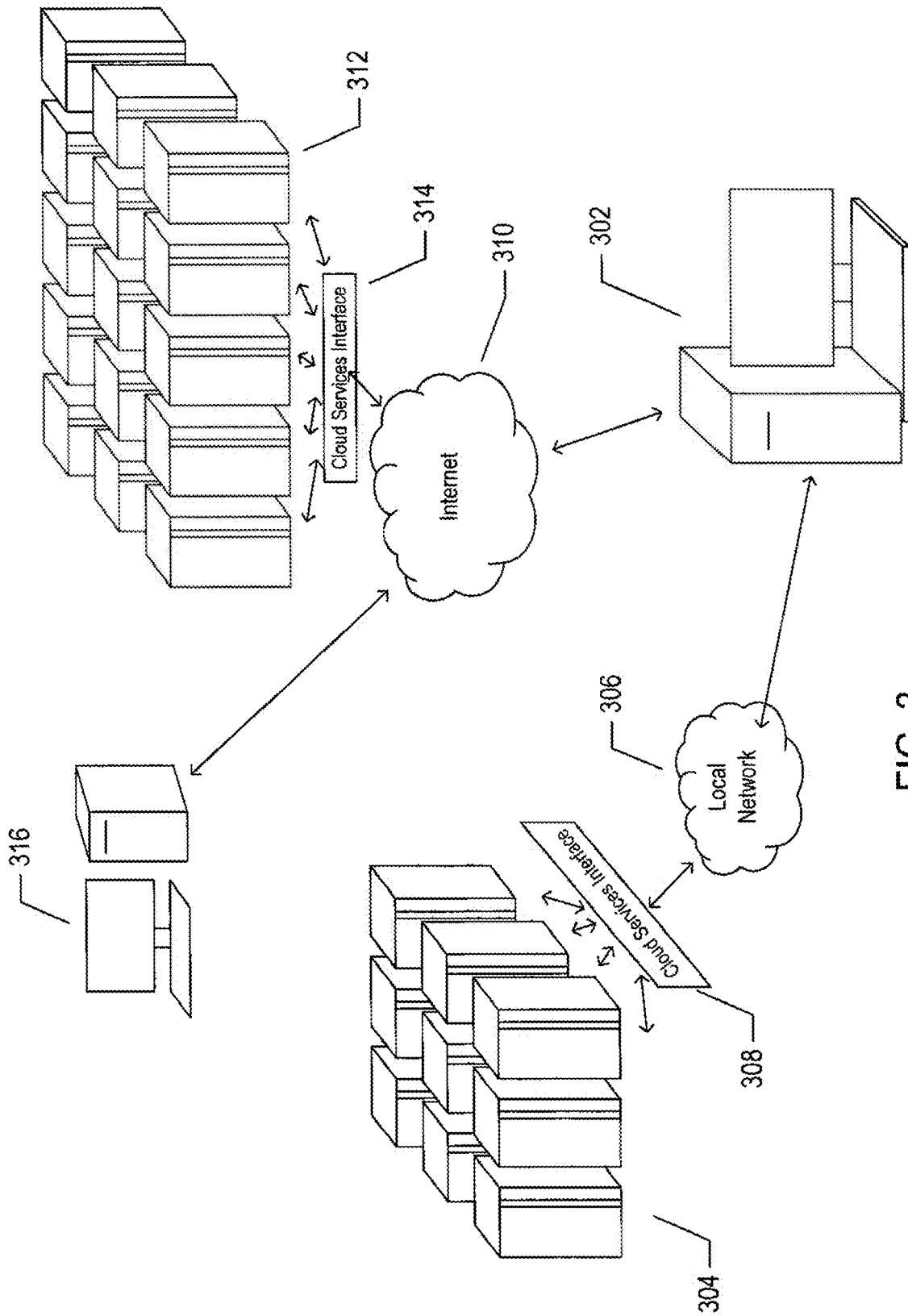

FIG. 3

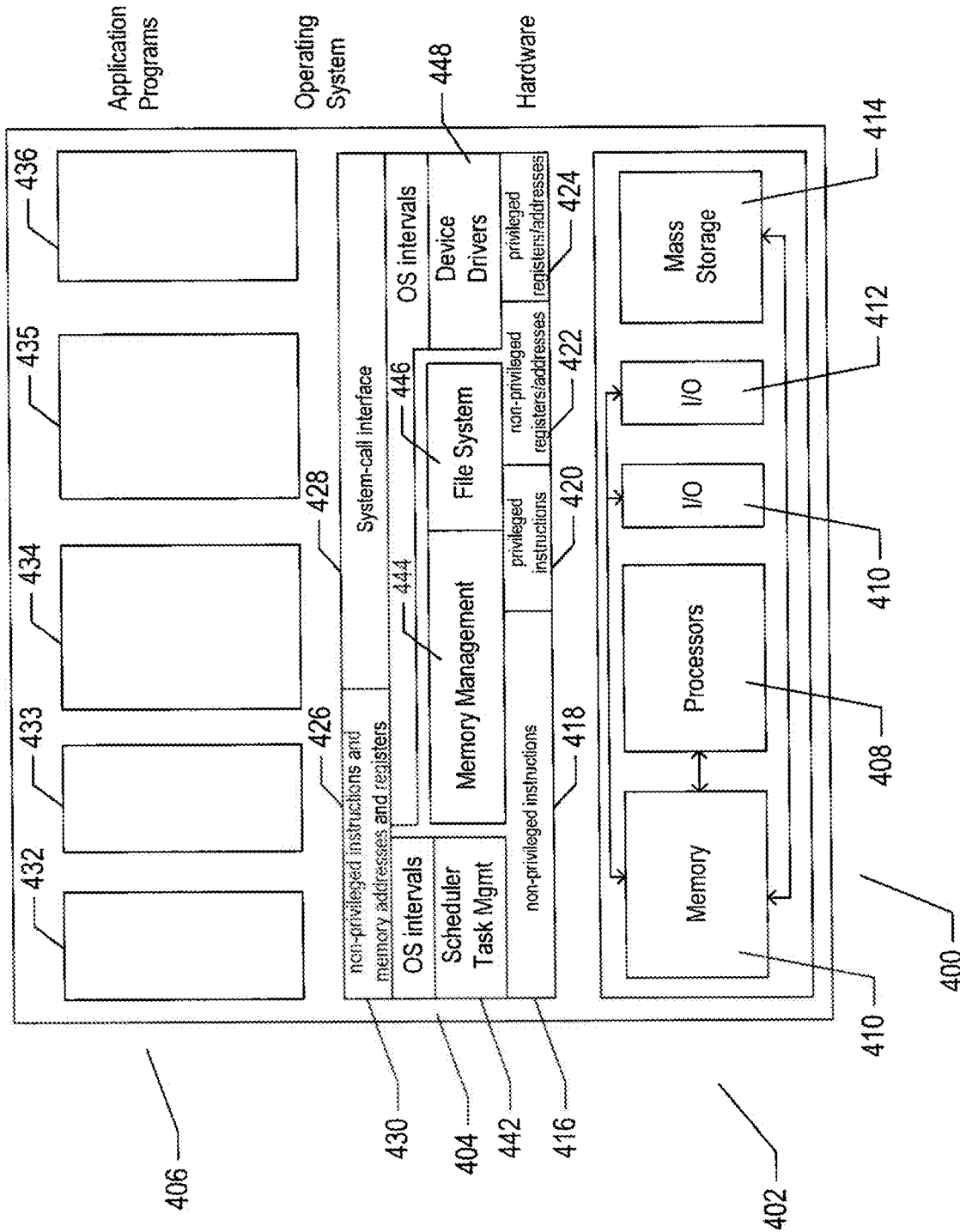

FIG. 4

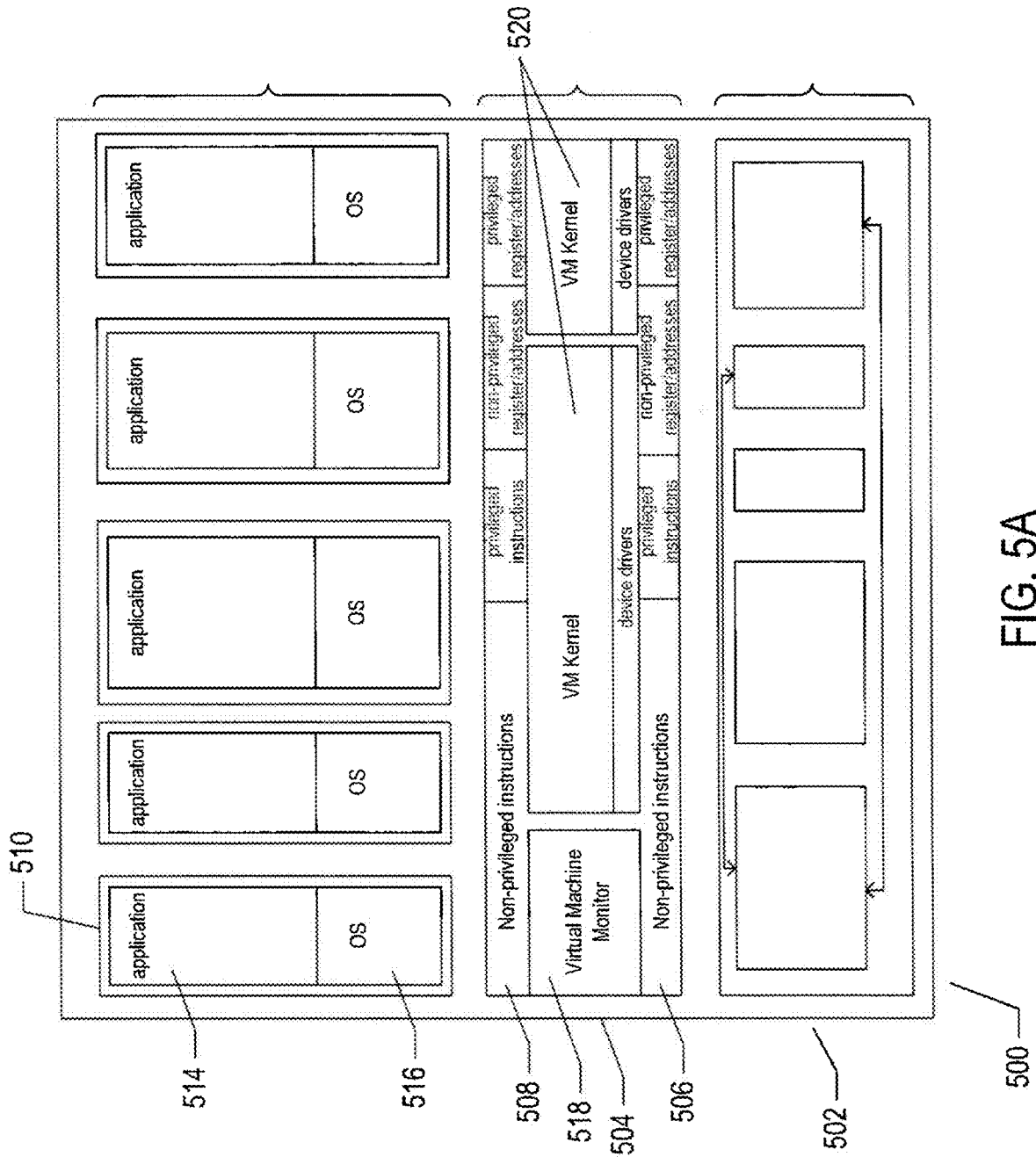
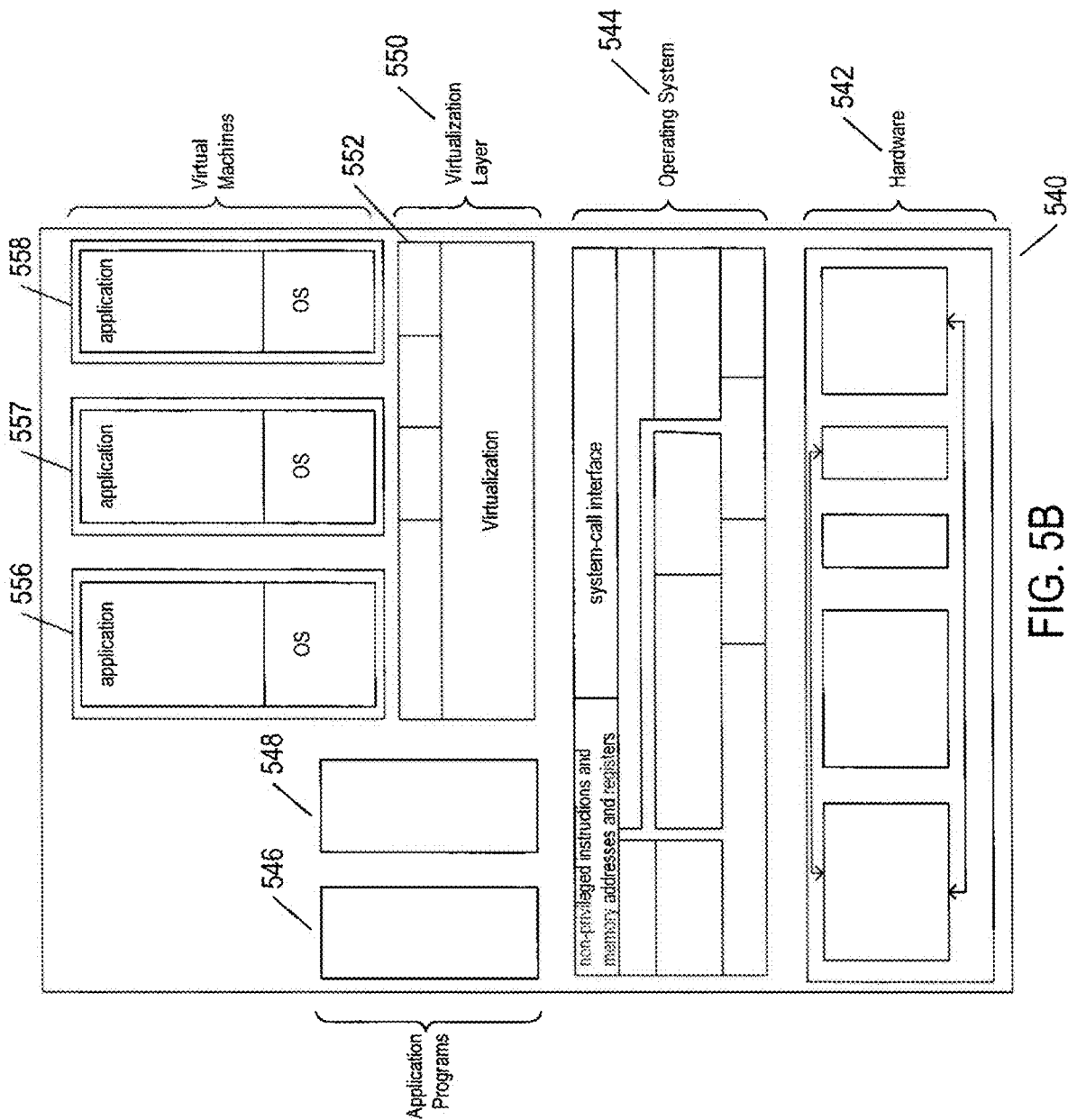

FIG. 5A



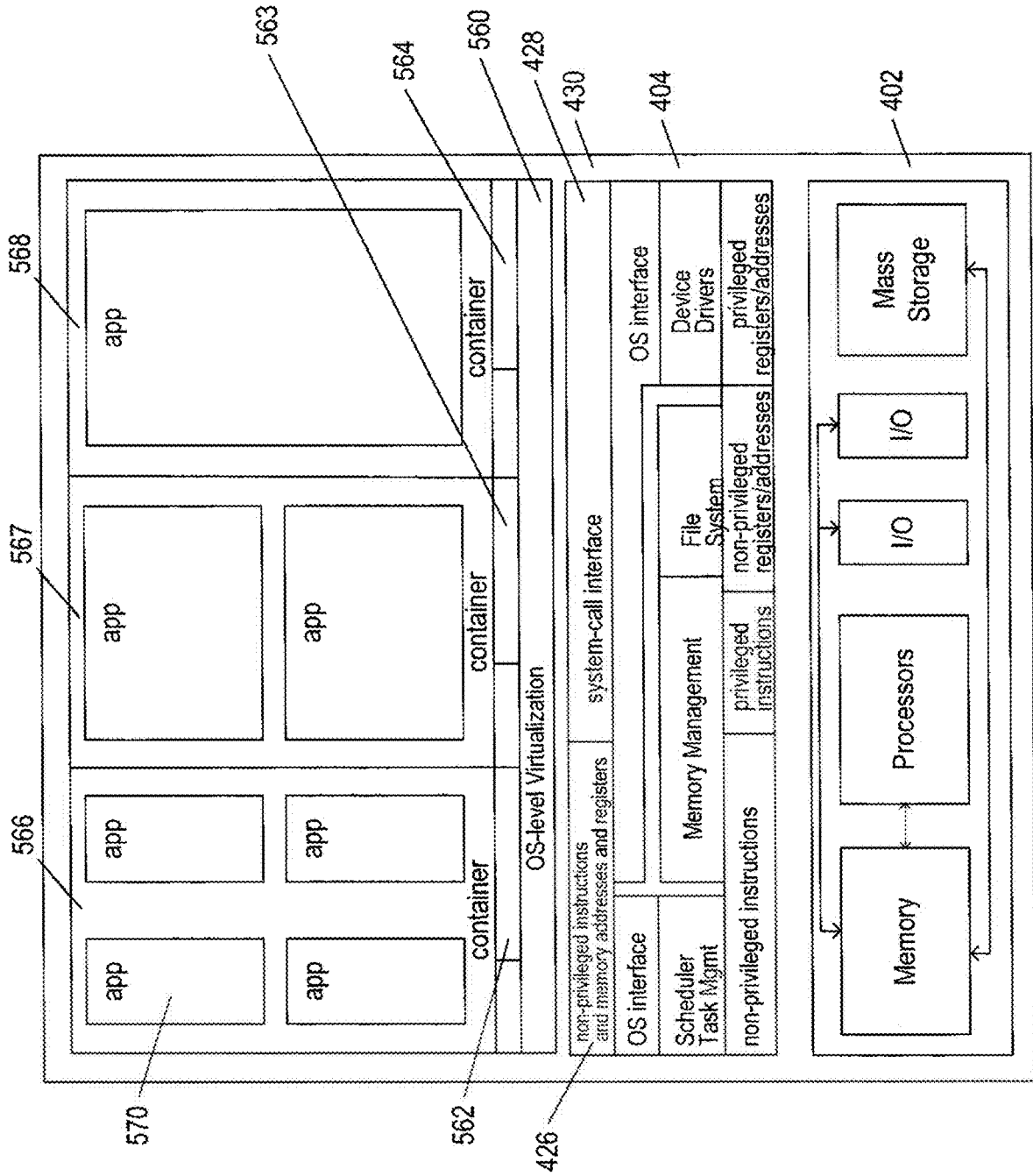

FIG. 5C



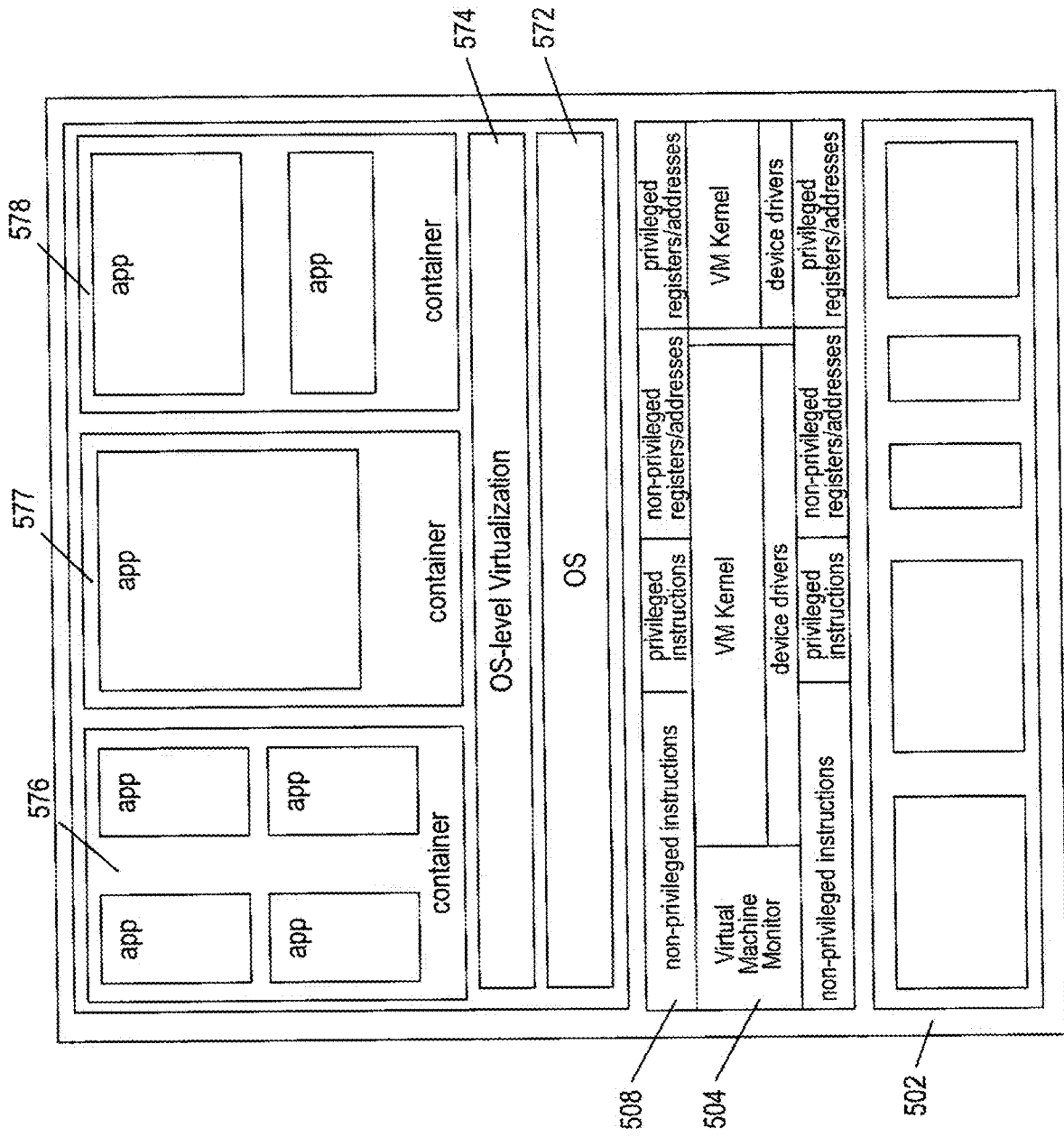
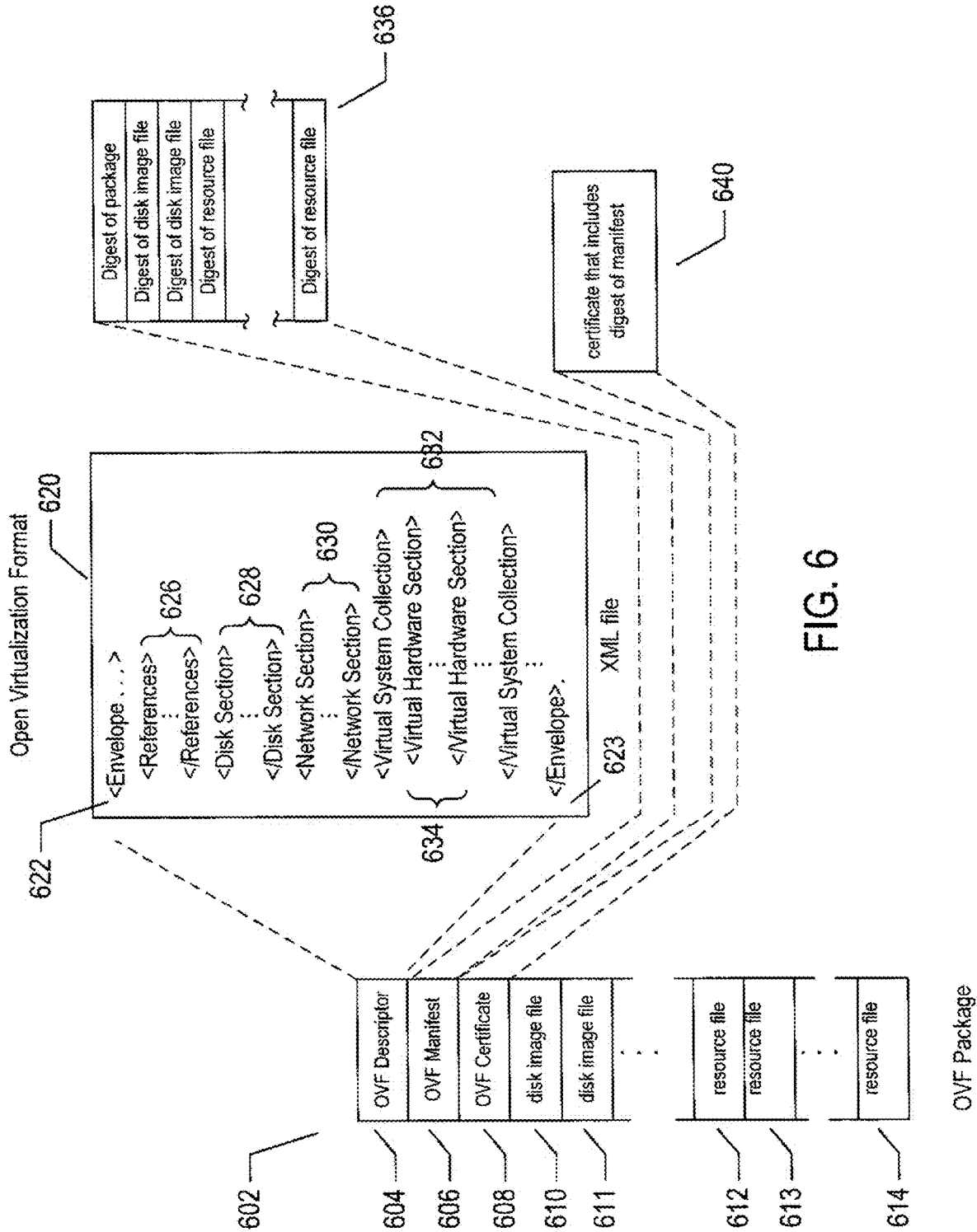
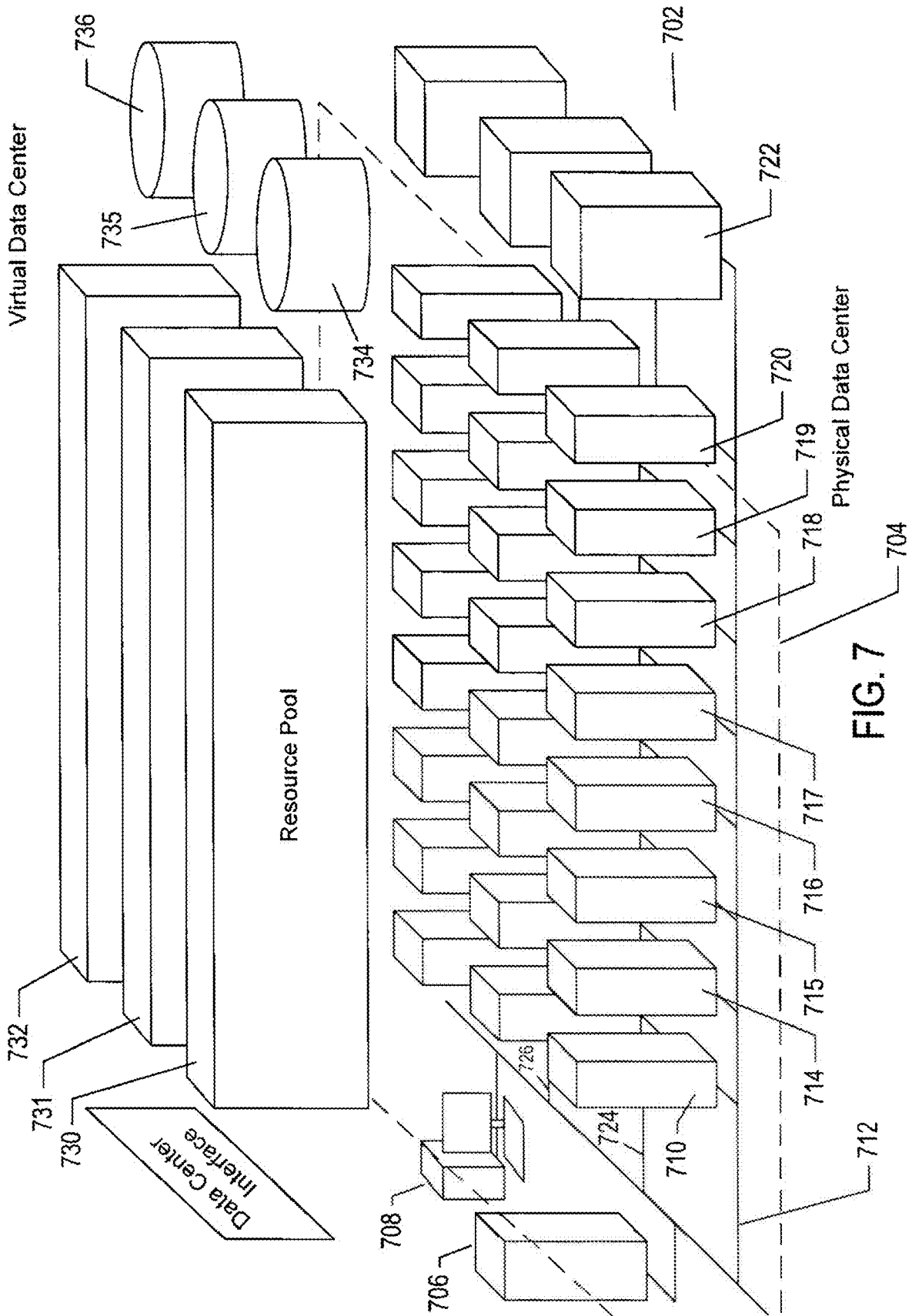

FIG. 5D





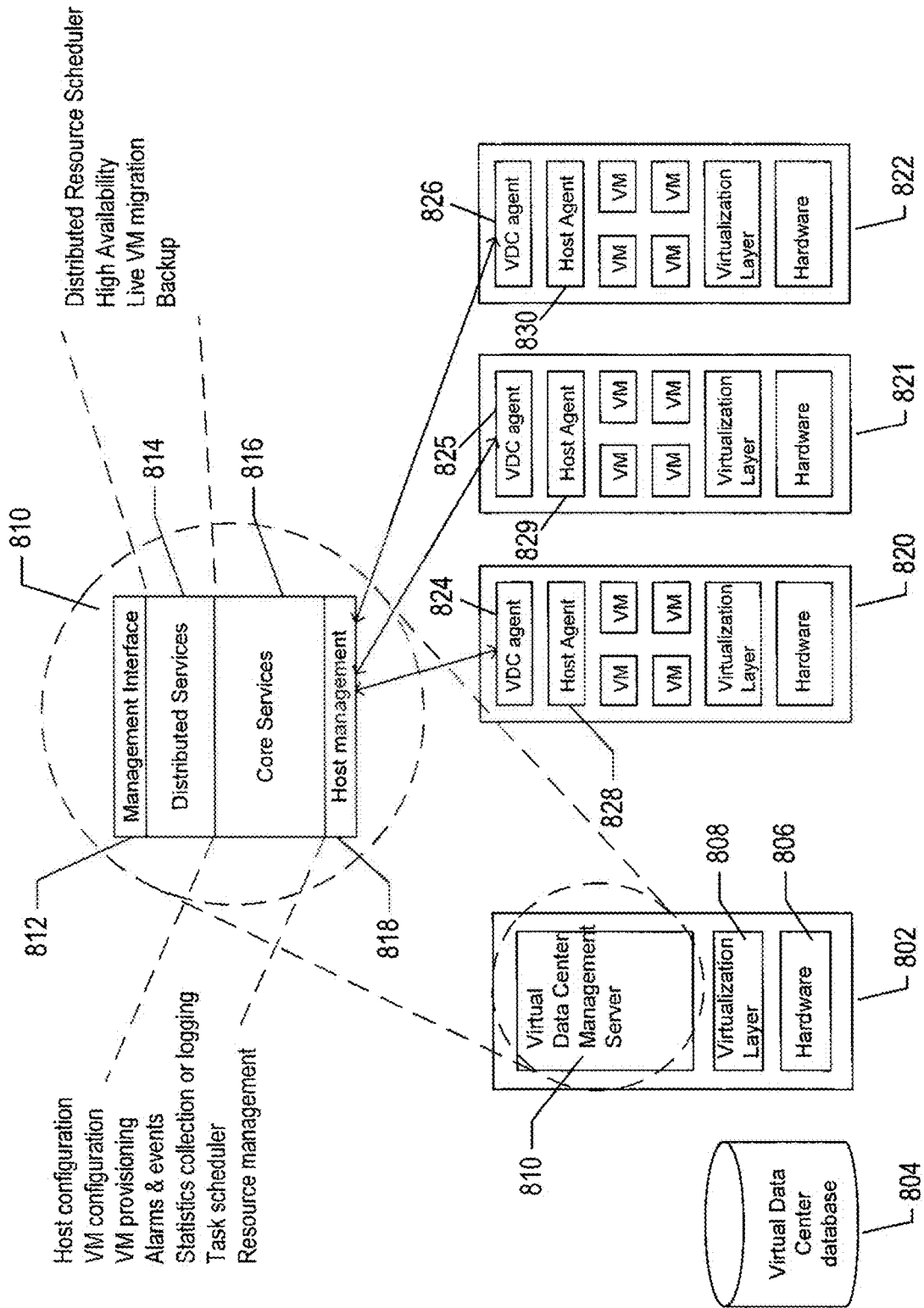

FIG. 8

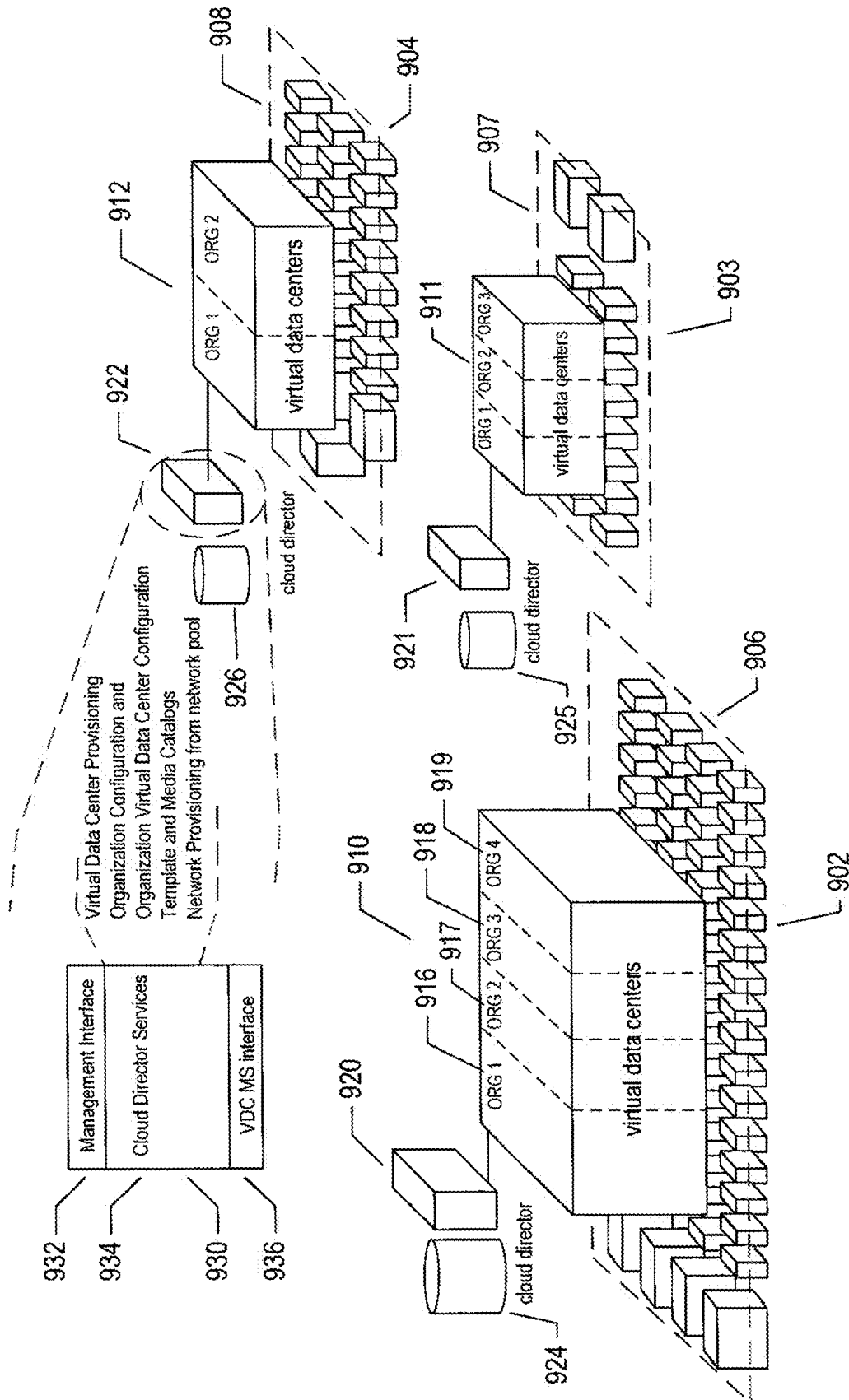

FIG. 9

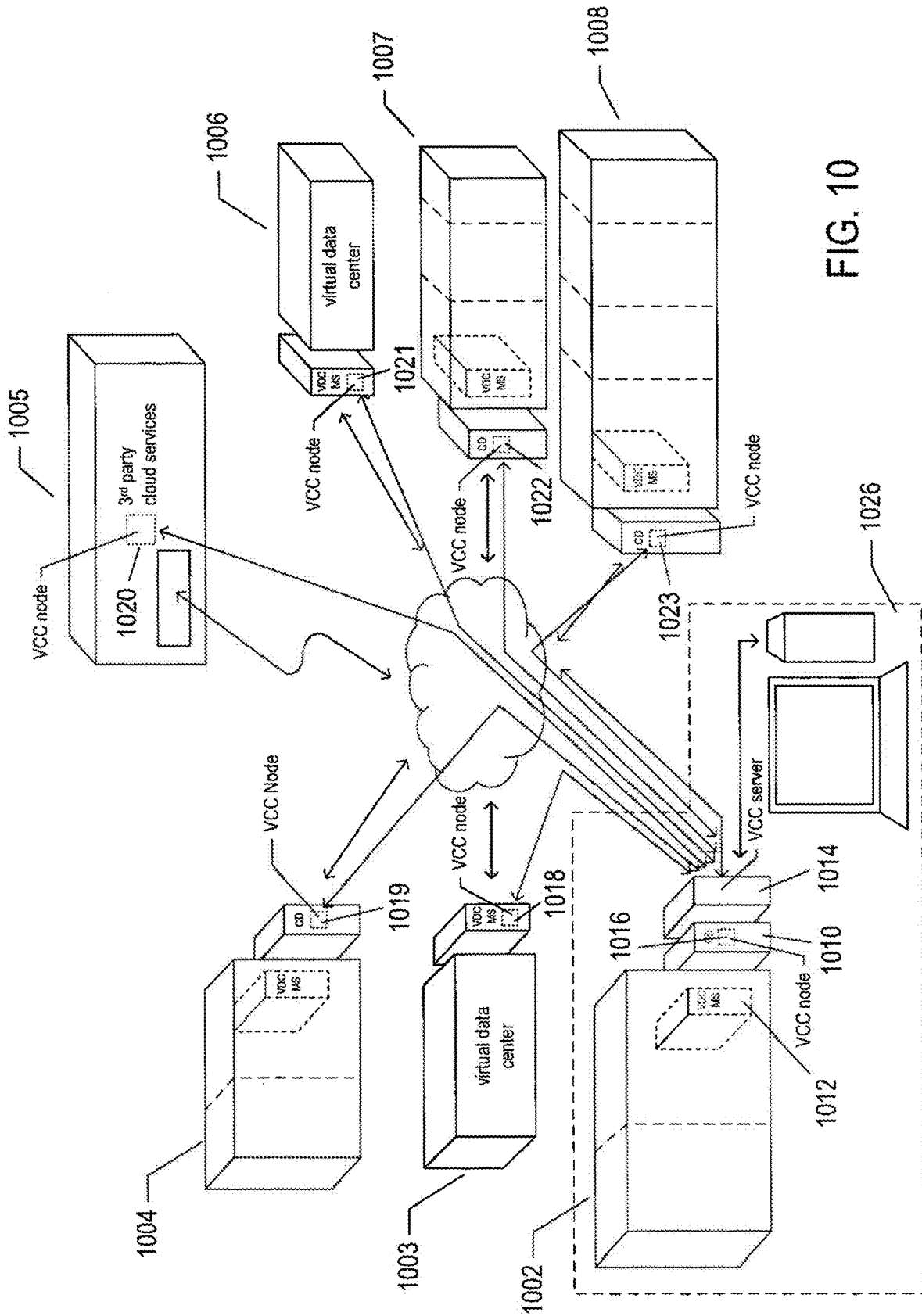

FIG. 10

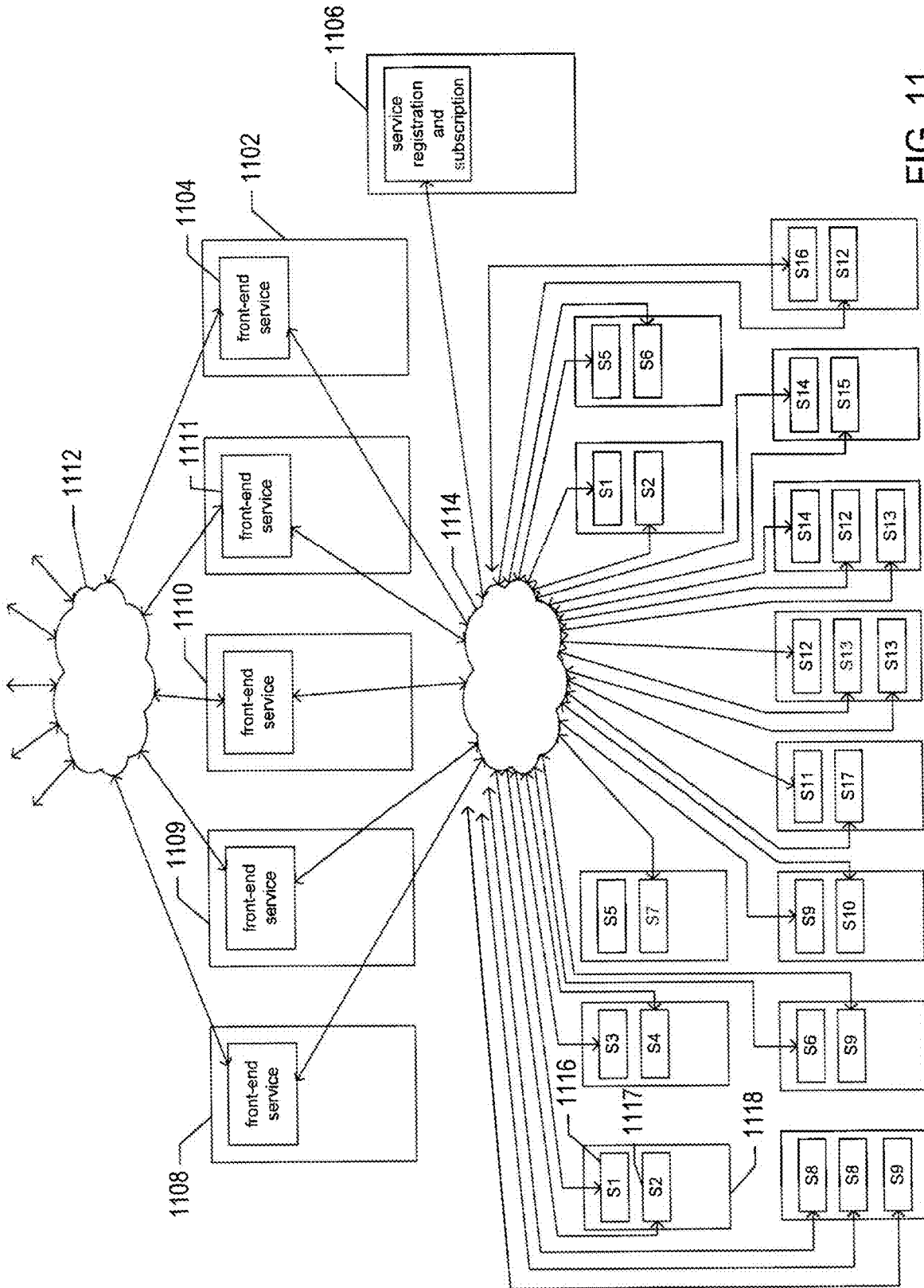

FIG. 11

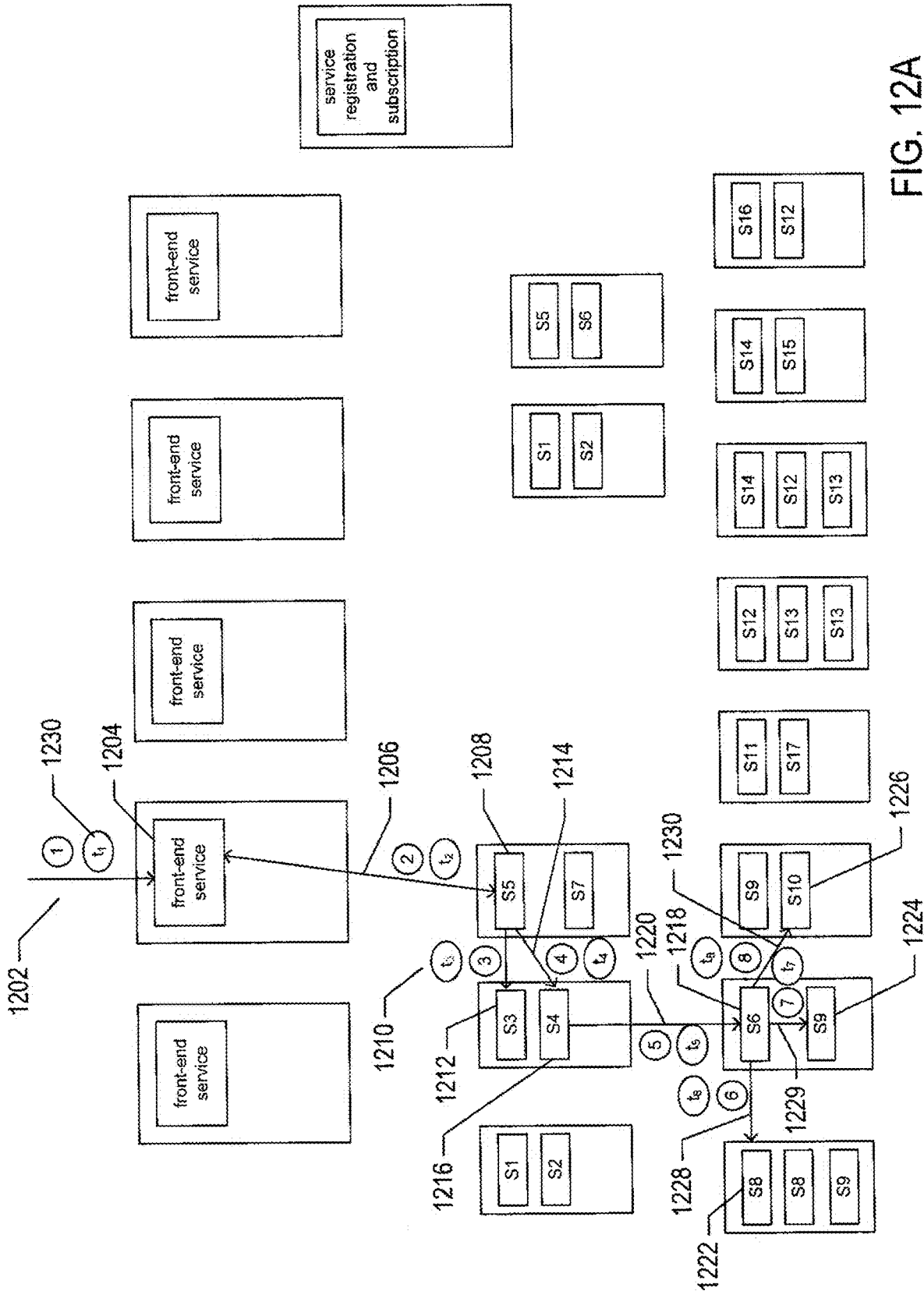

FIG. 12A



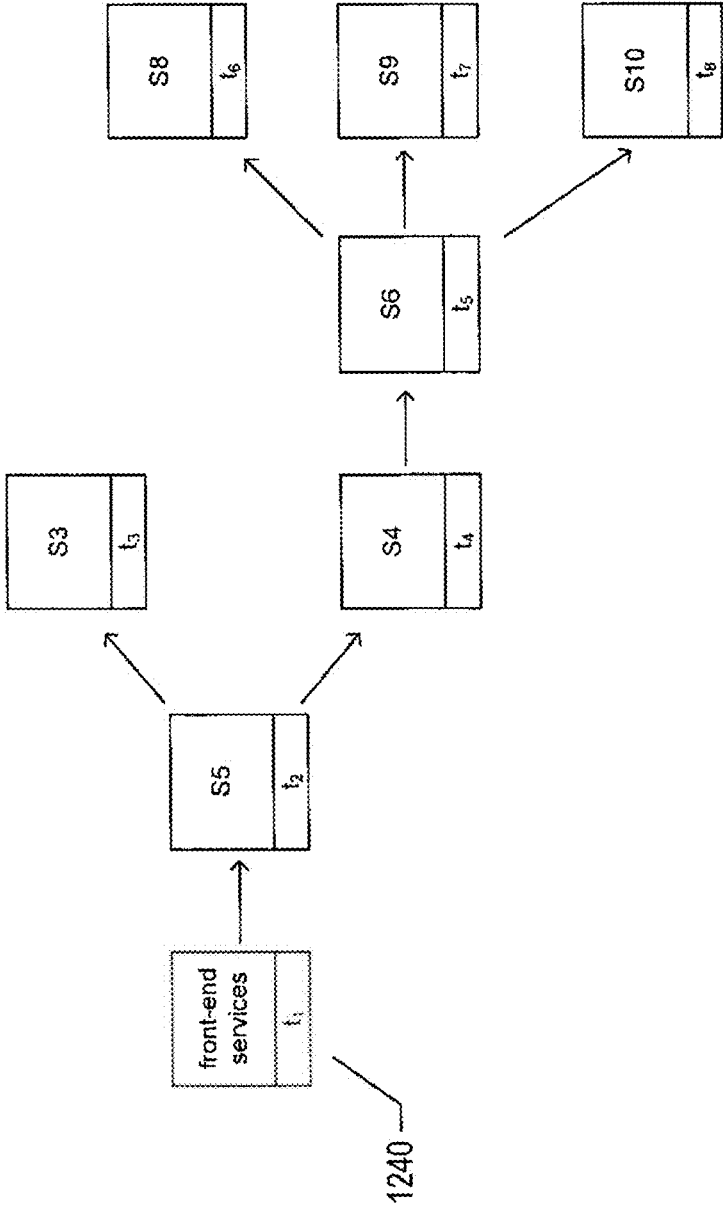

FIG. 12B

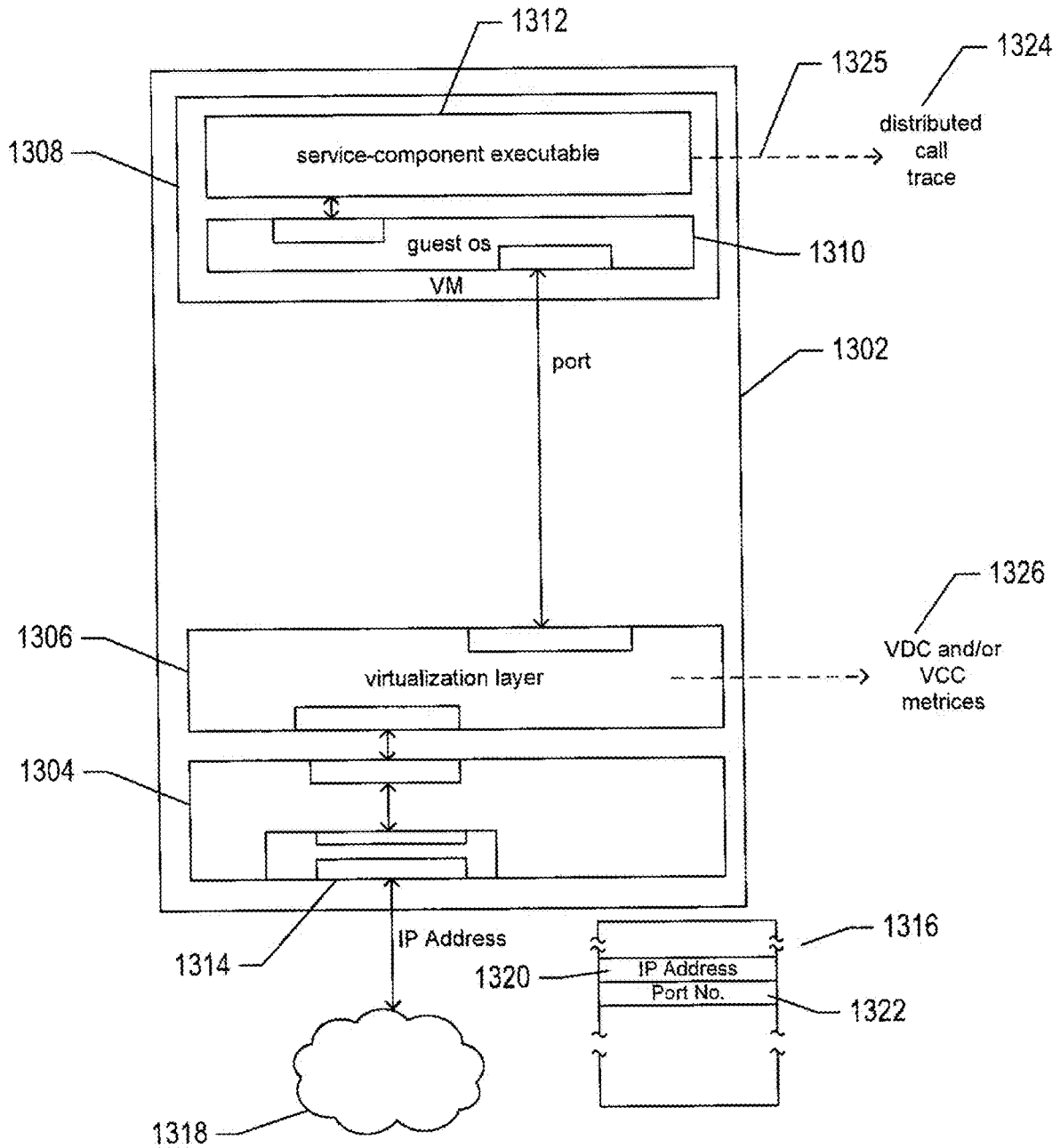

FIG. 13A

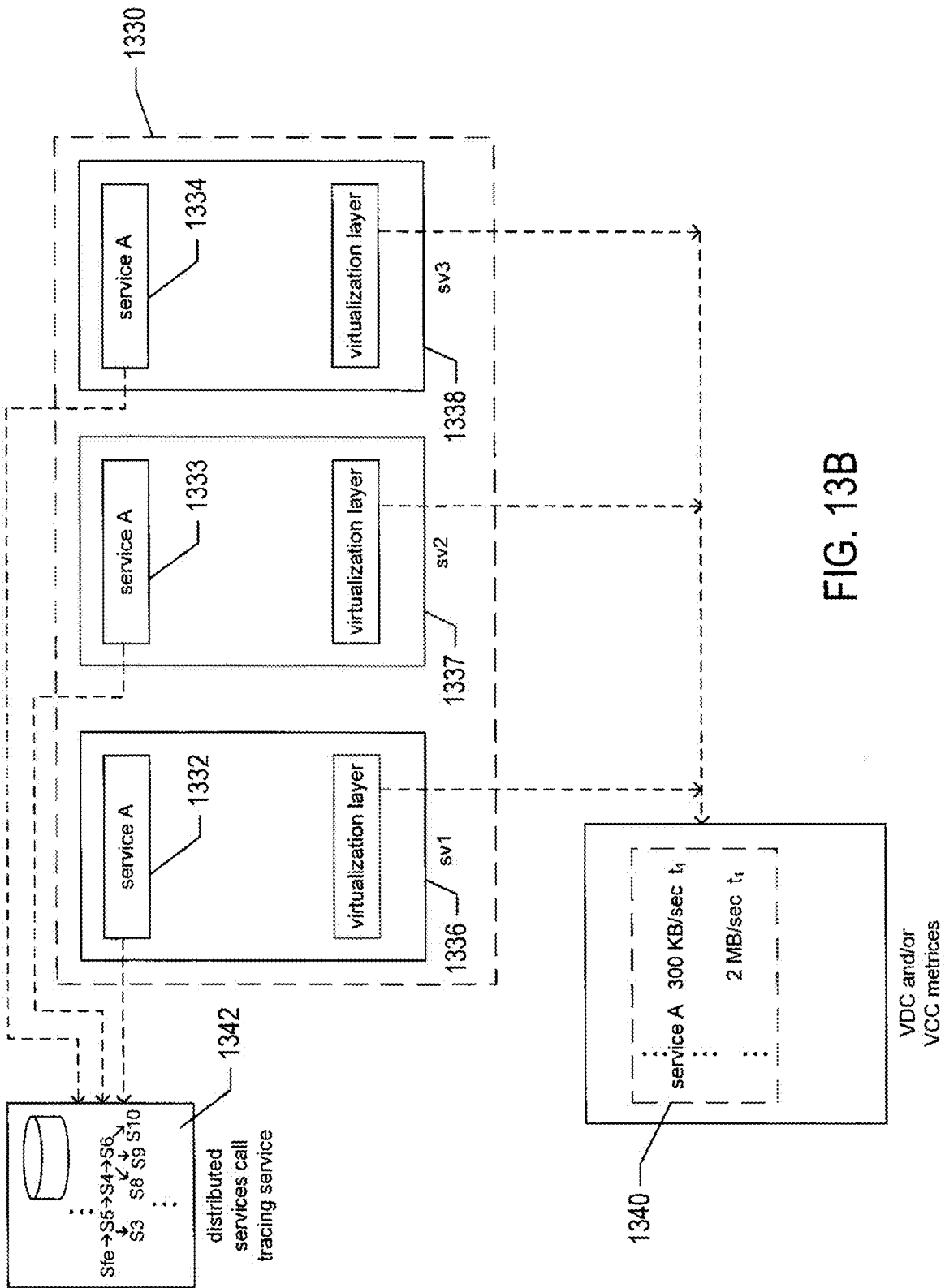

FIG. 13B

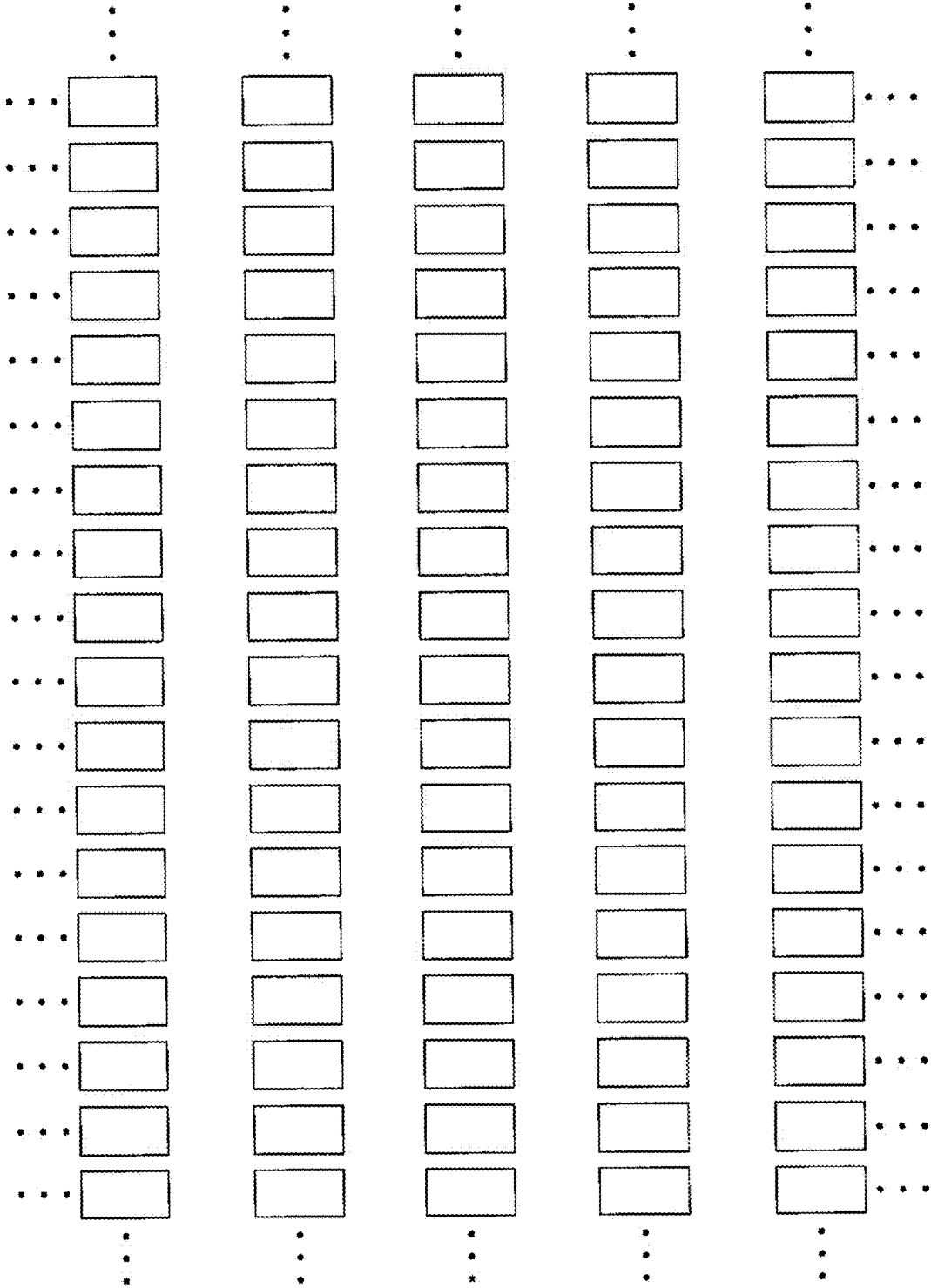

FIG. 14A

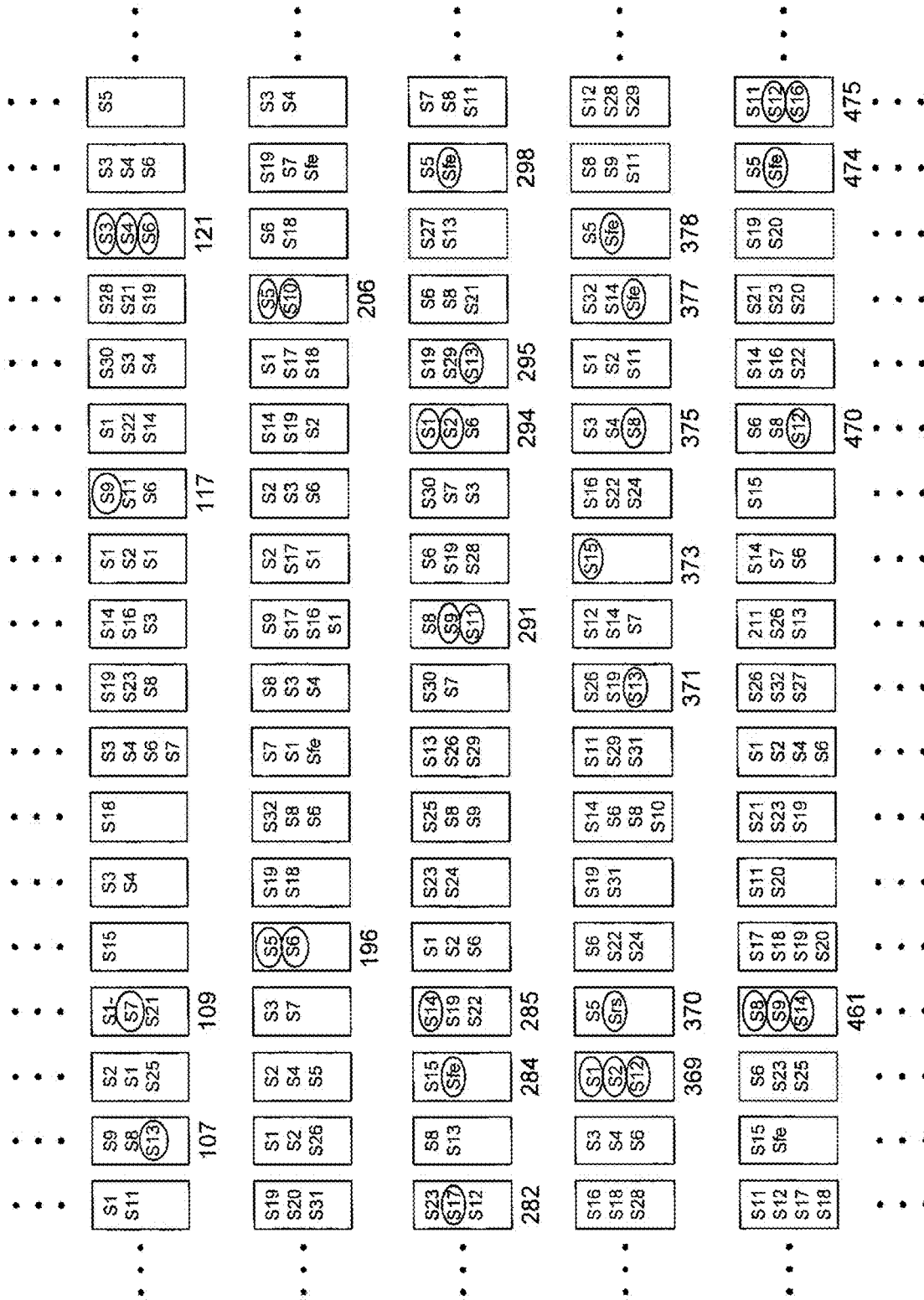

FIG. 14B

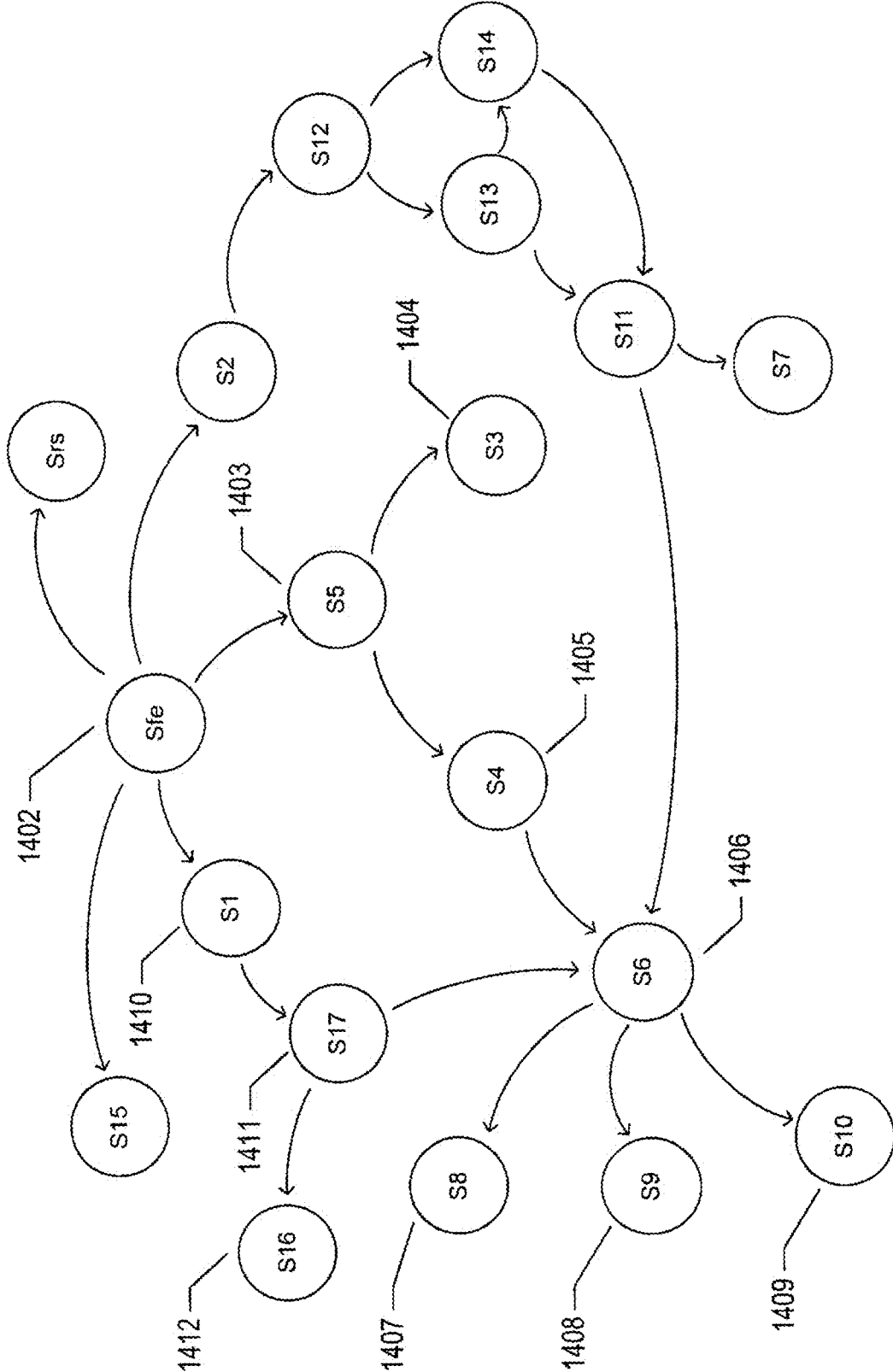

FIG. 14C

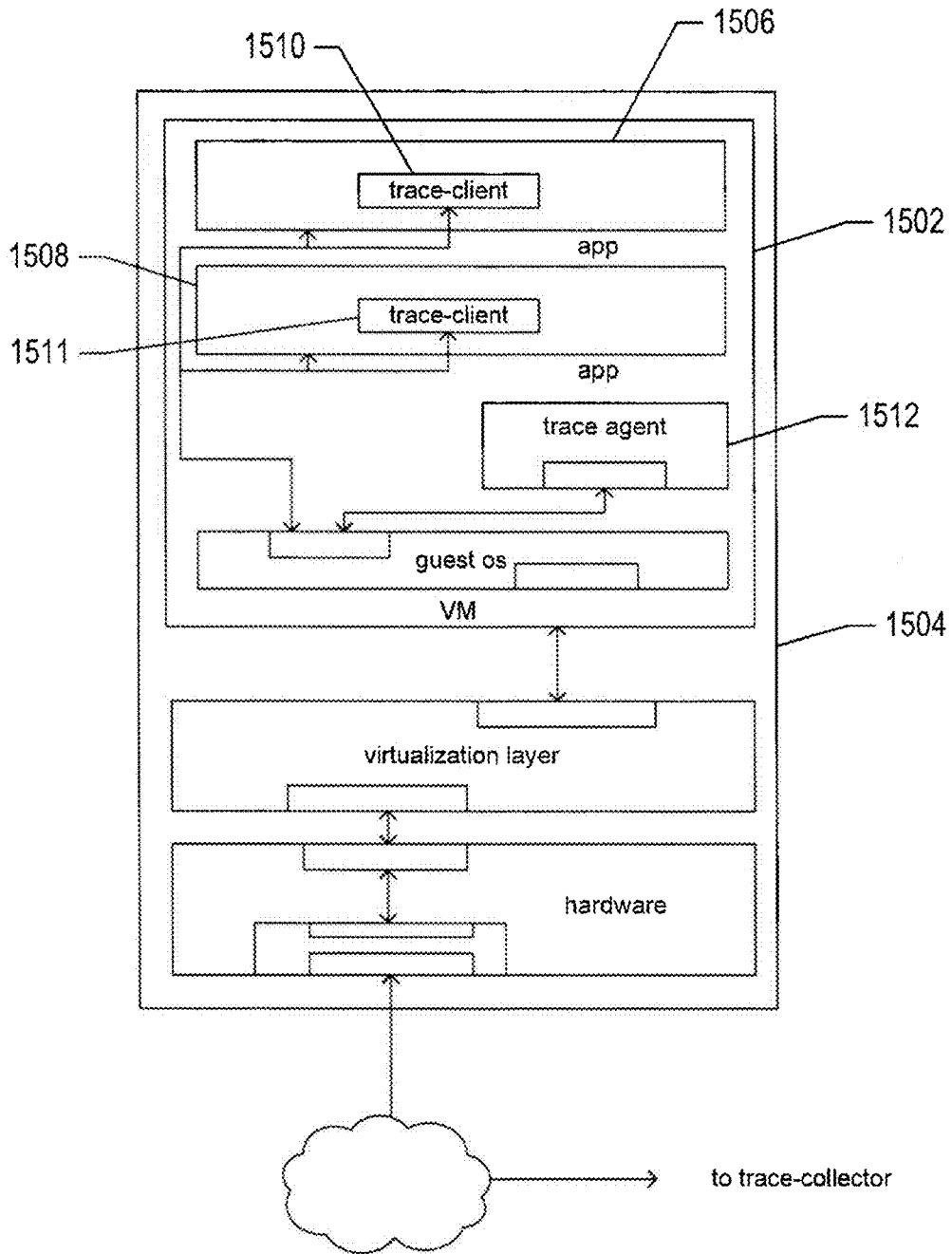

FIG. 15A

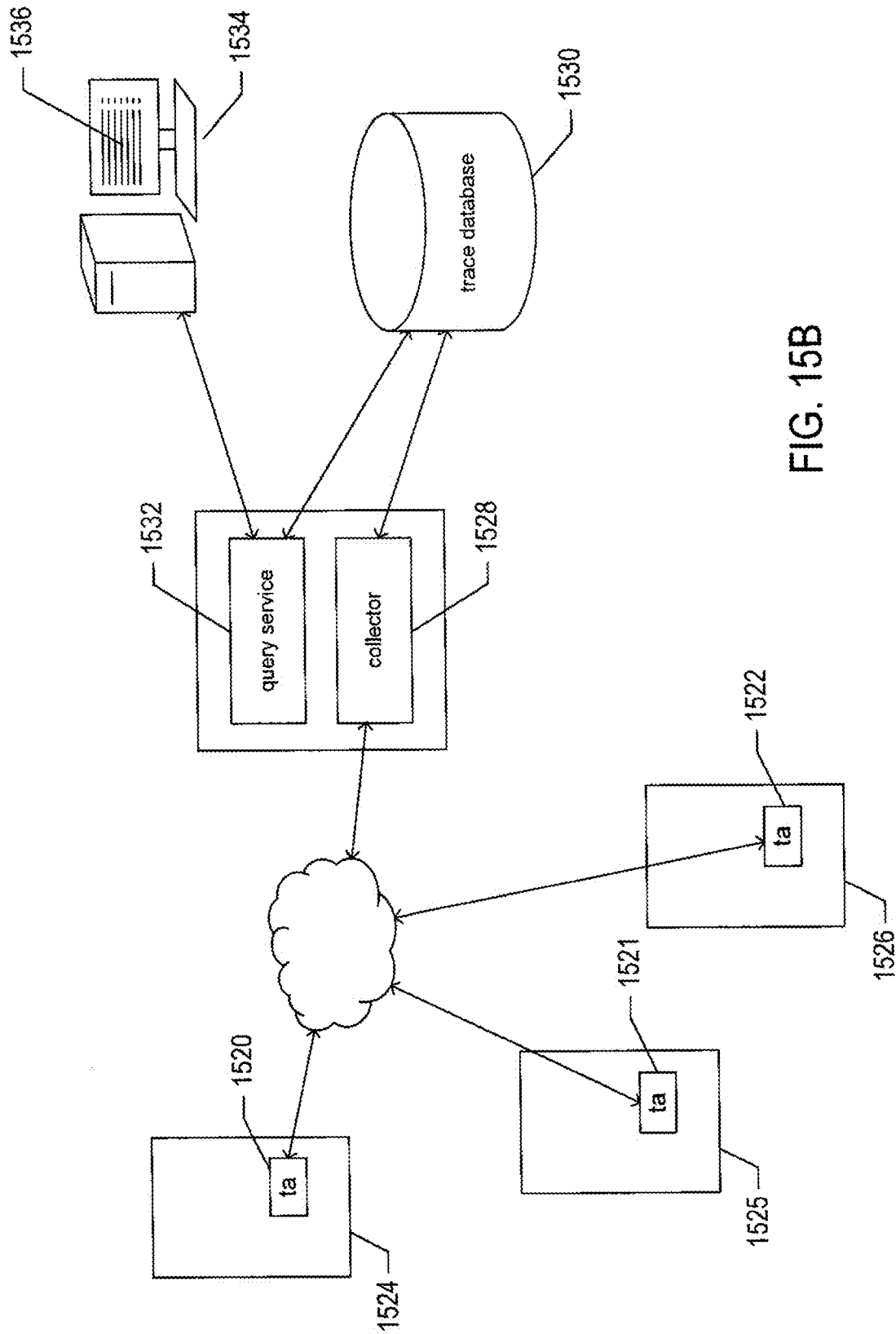

FIG. 15B



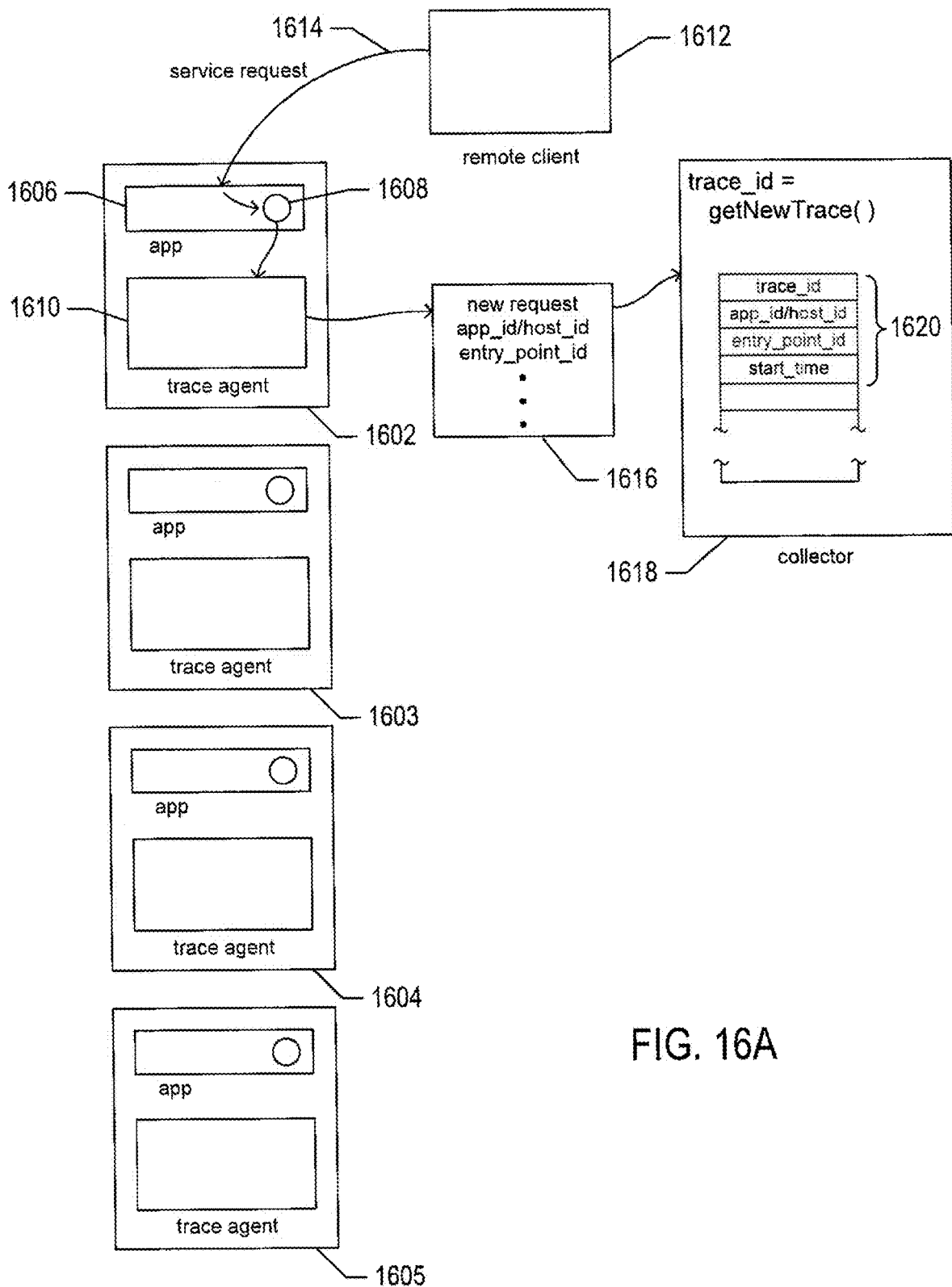

FIG. 16A

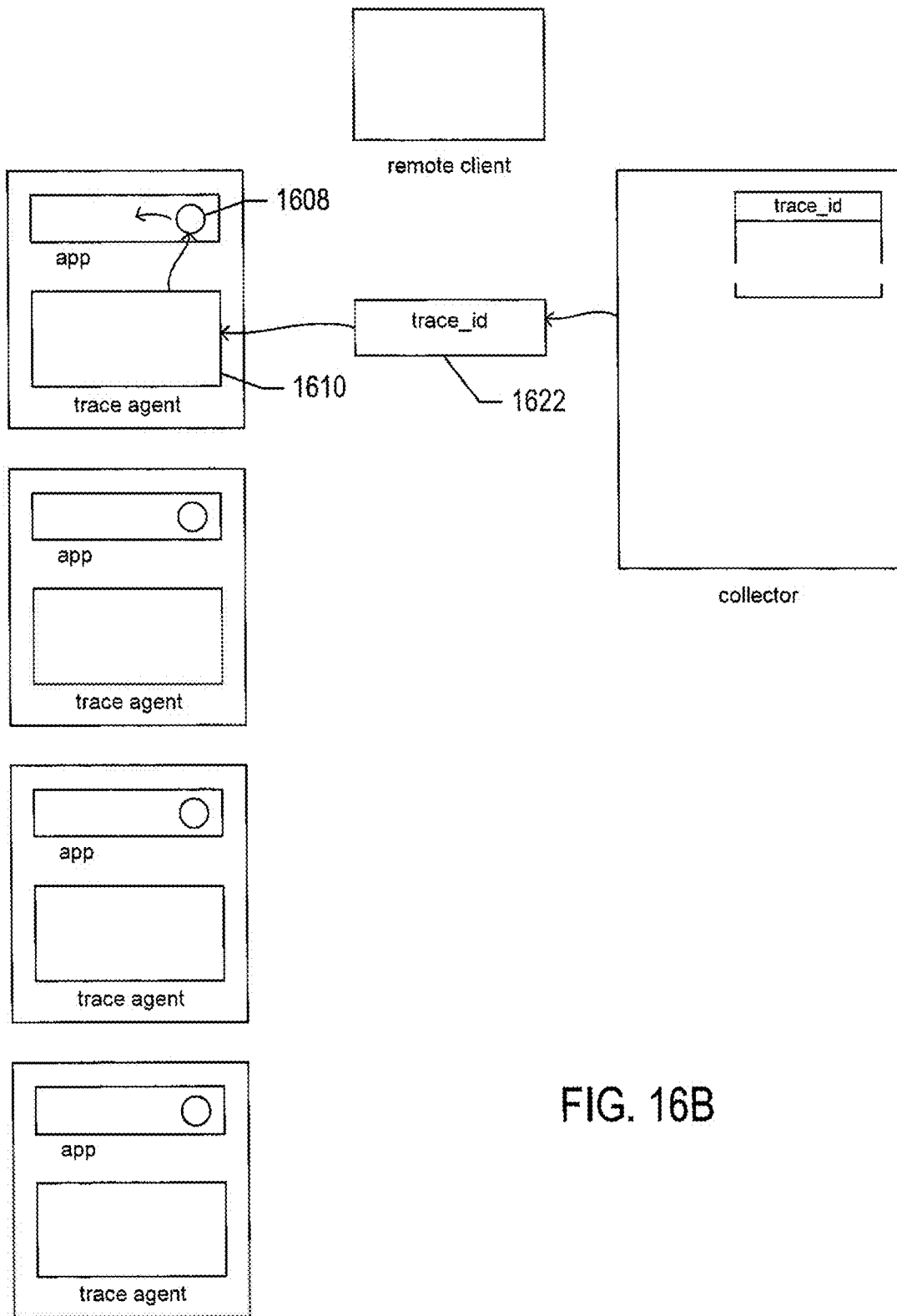

FIG. 16B

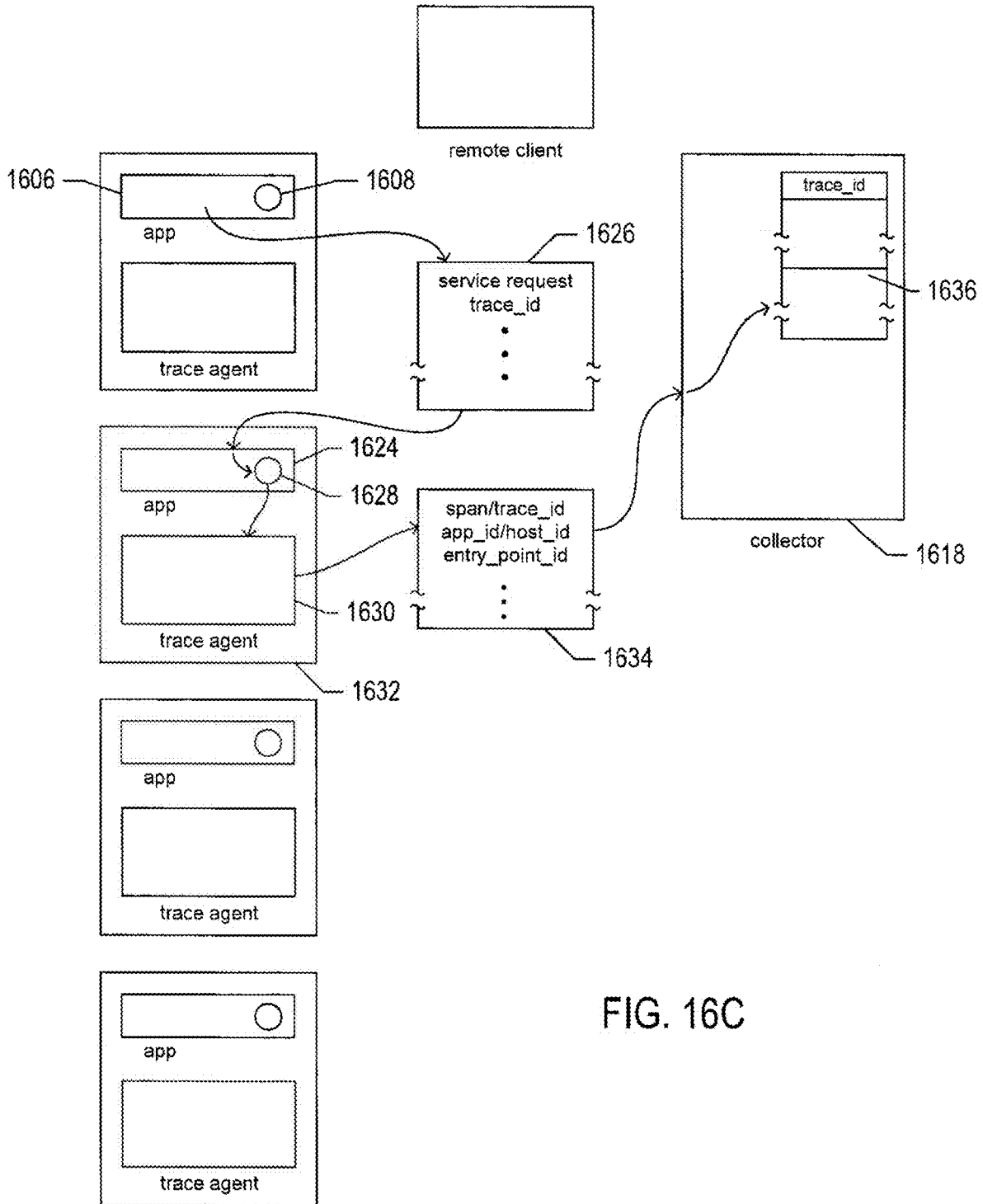

FIG. 16C

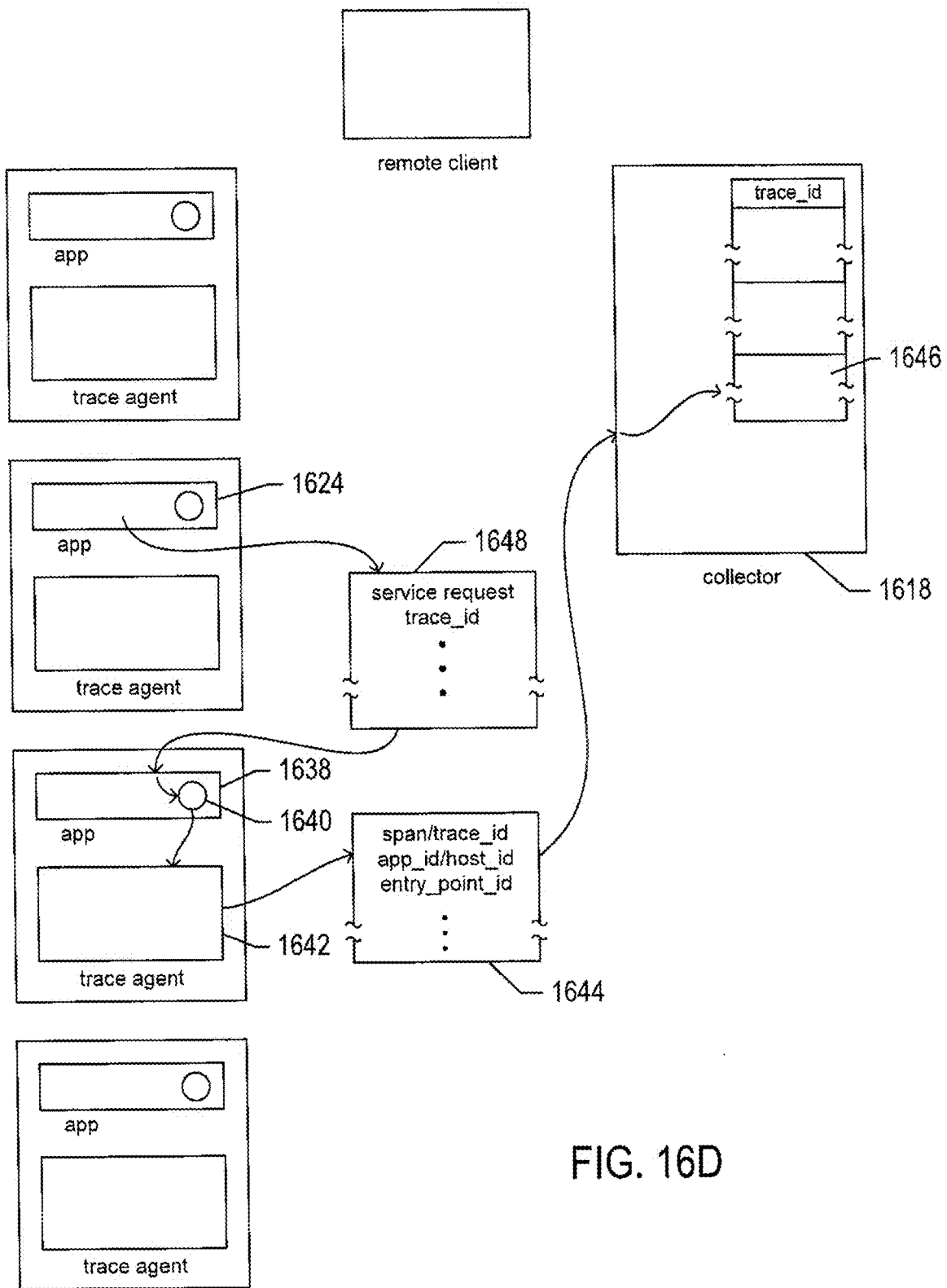

FIG. 16D

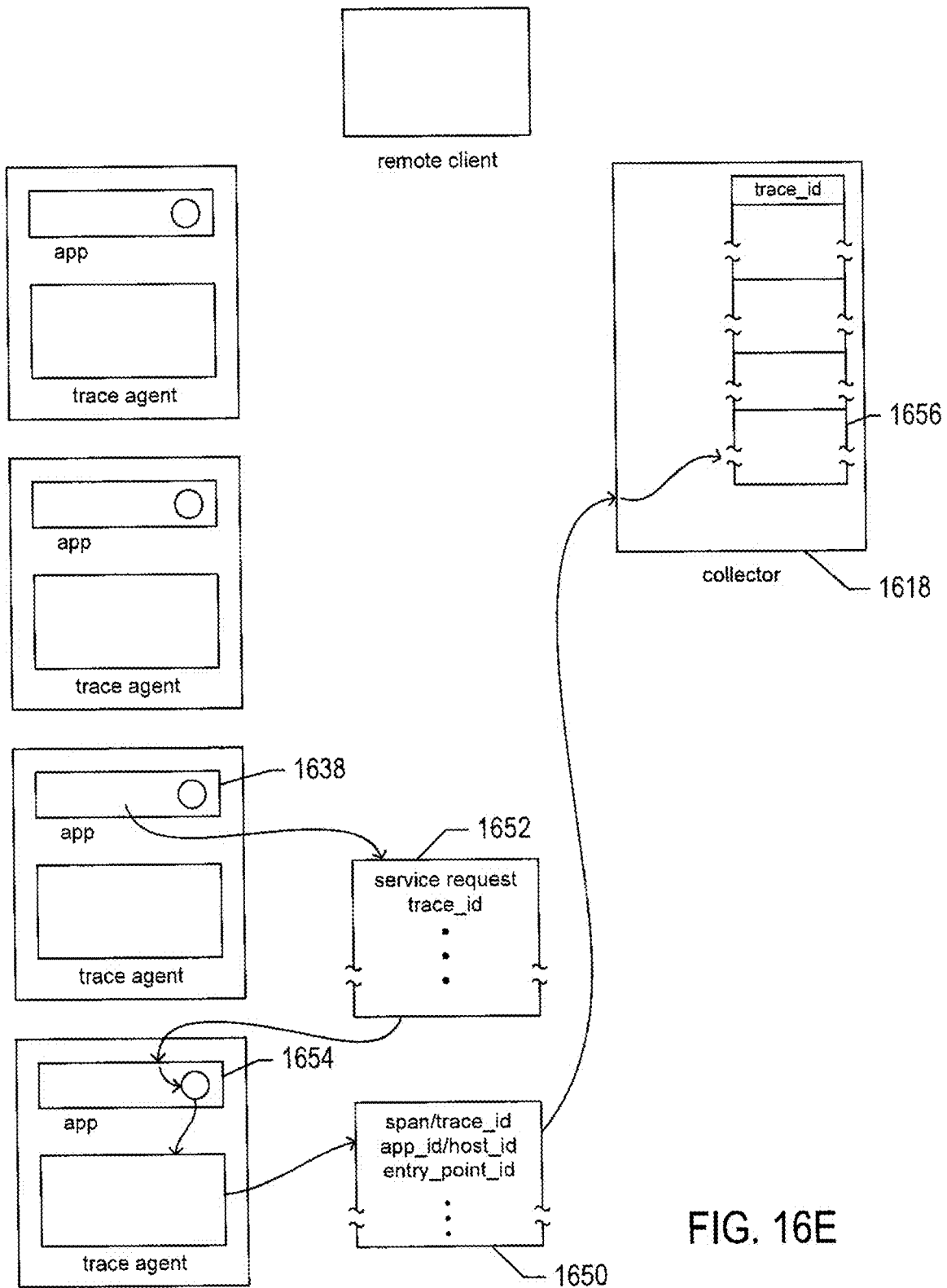

FIG. 16E

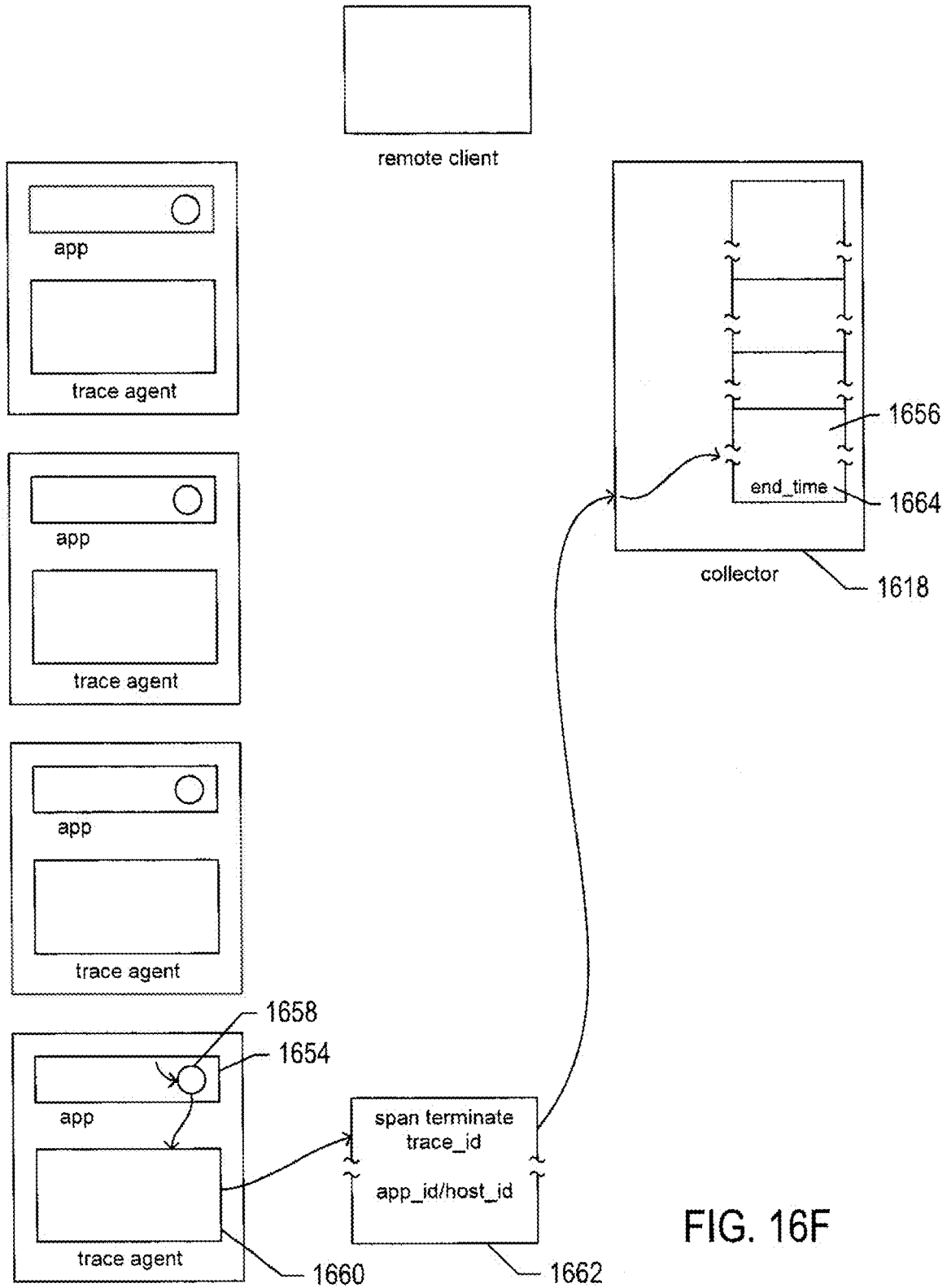

FIG. 16F

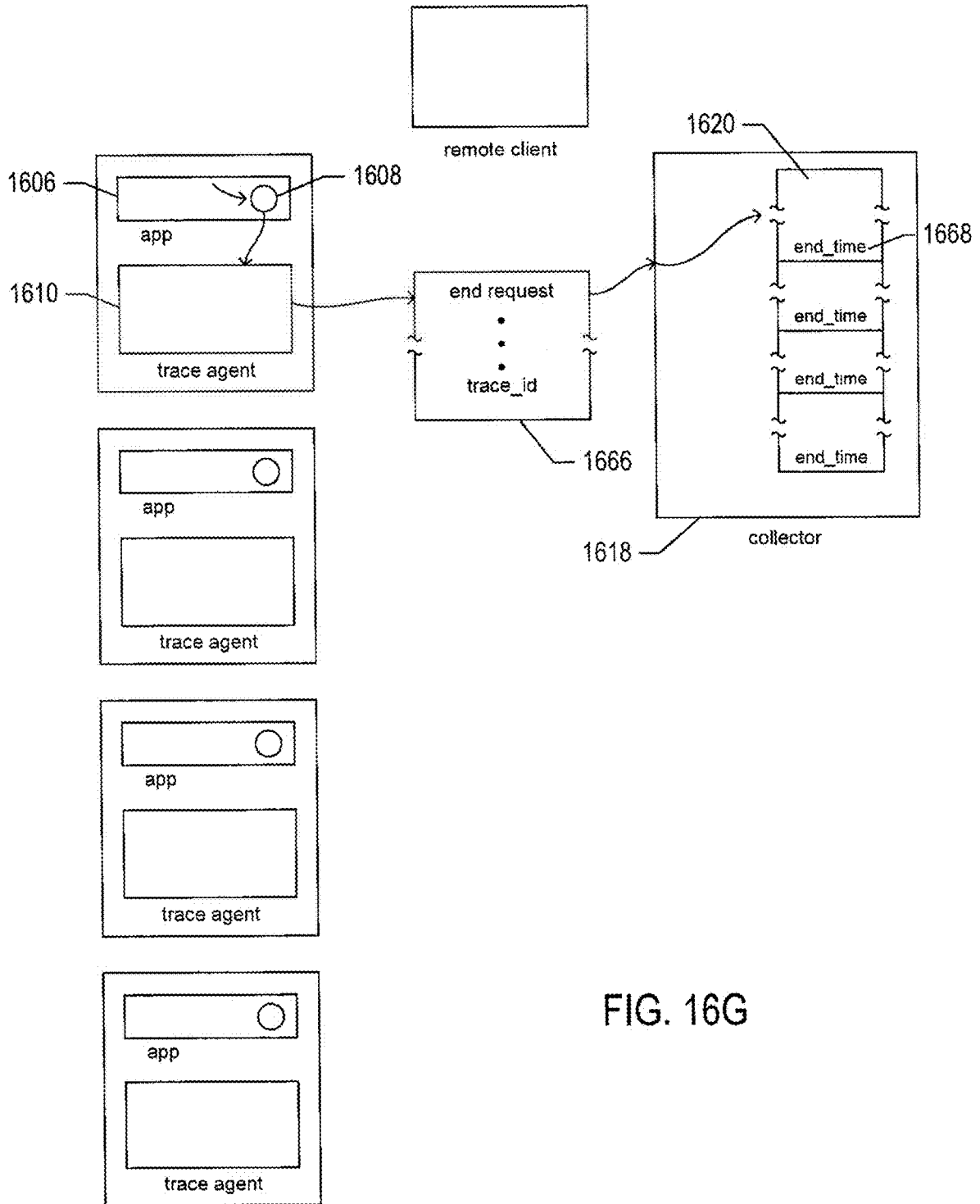

FIG. 16G

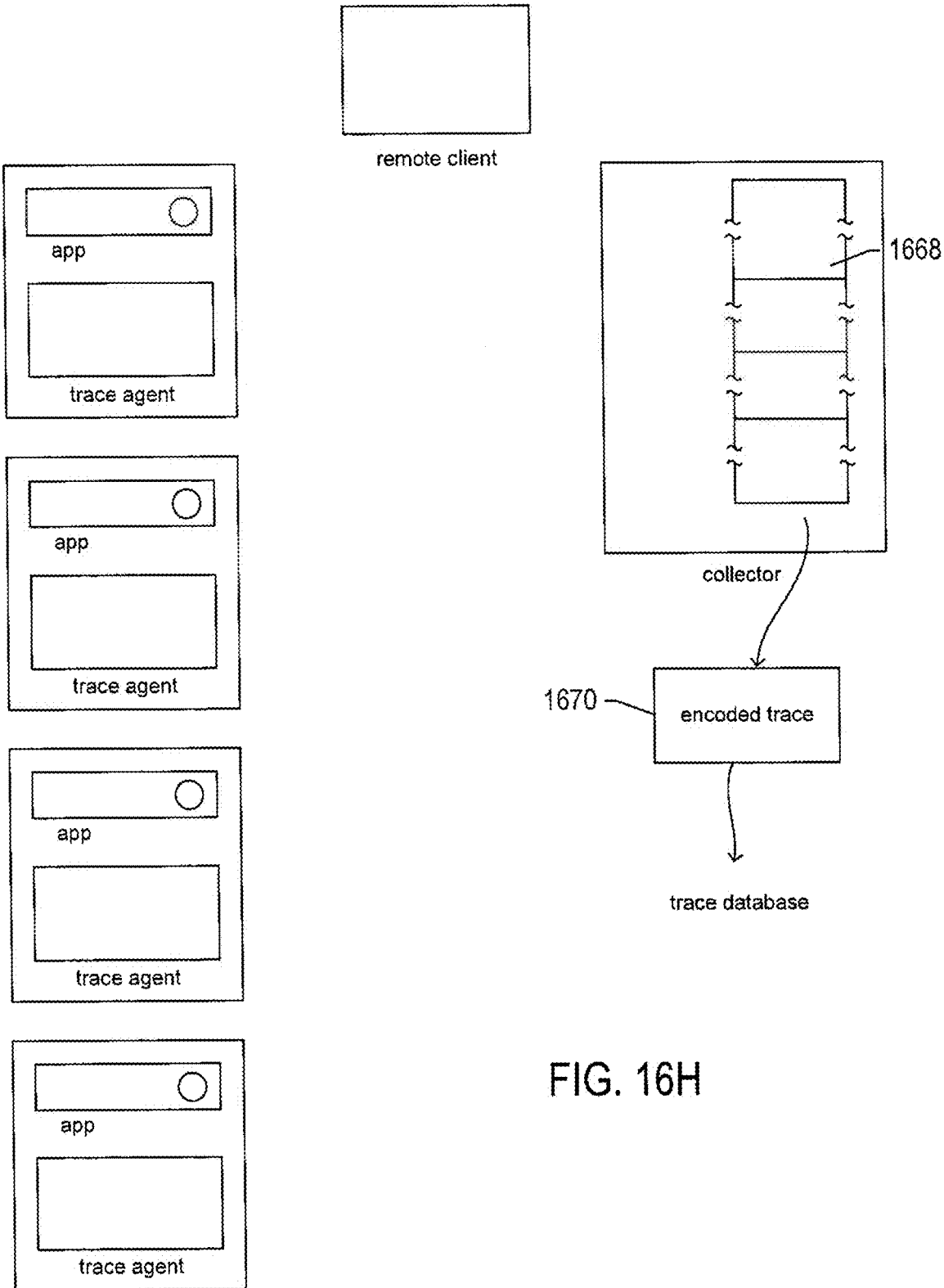

FIG. 16H



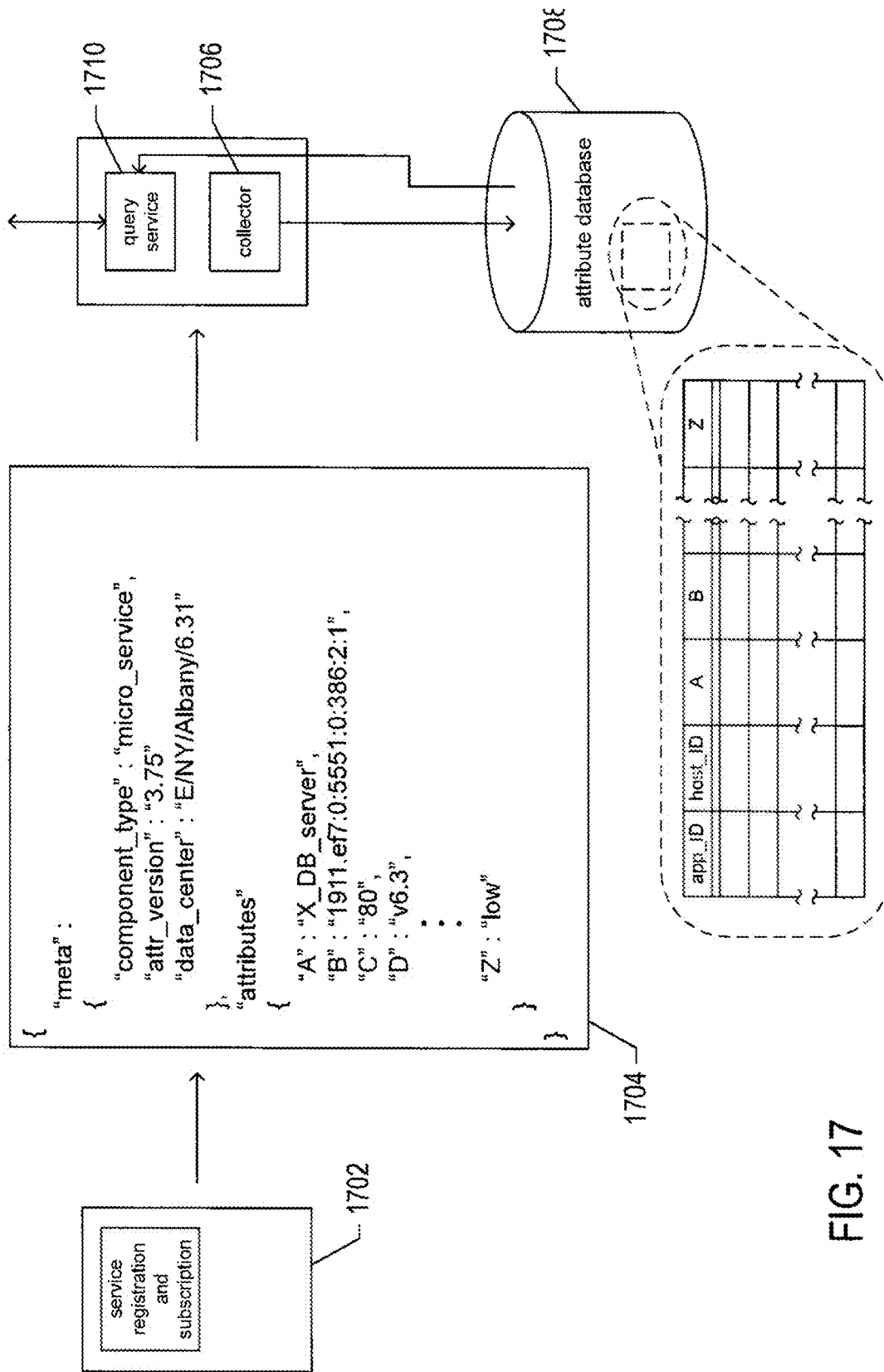

FIG. 17

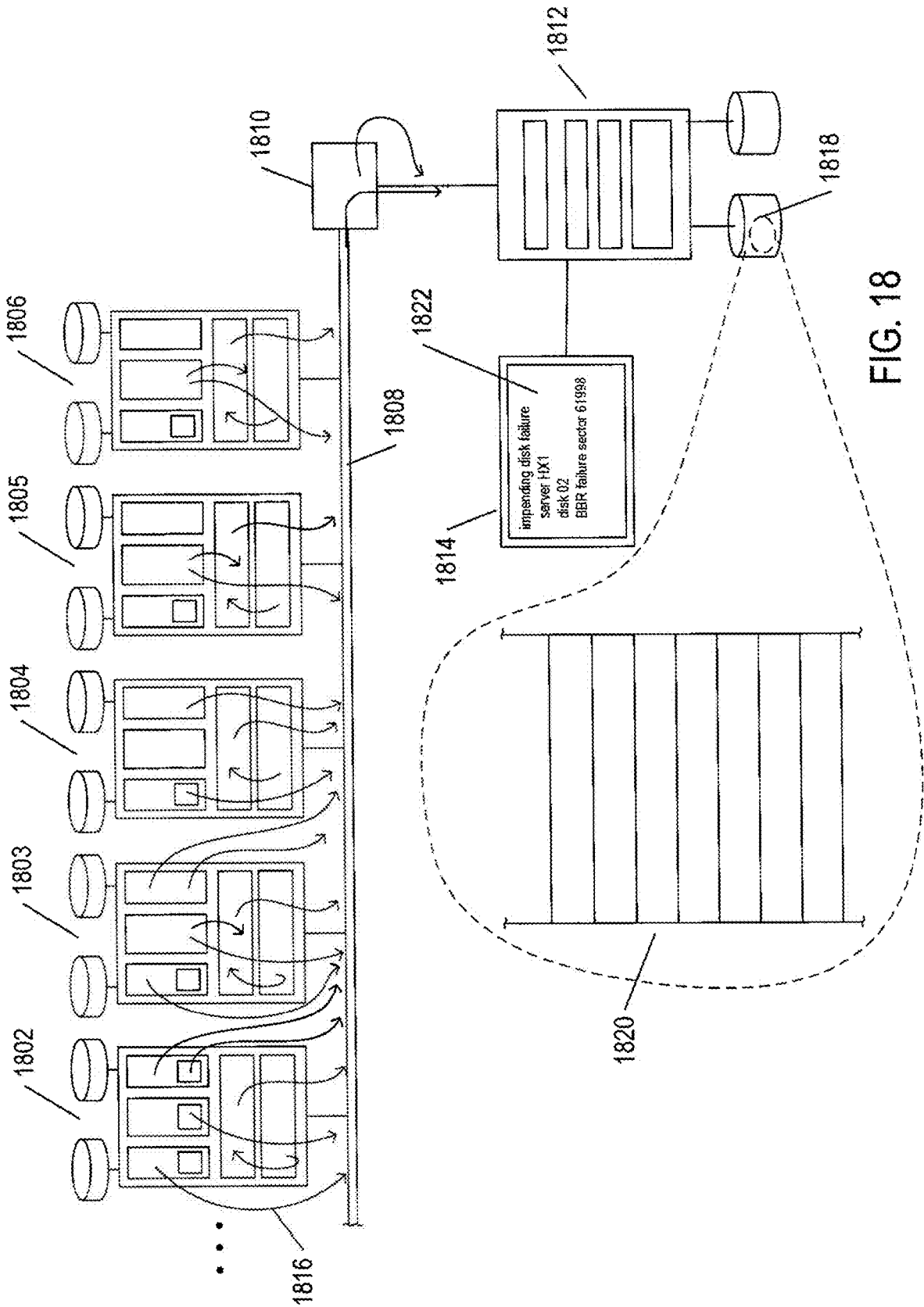

FIG. 18

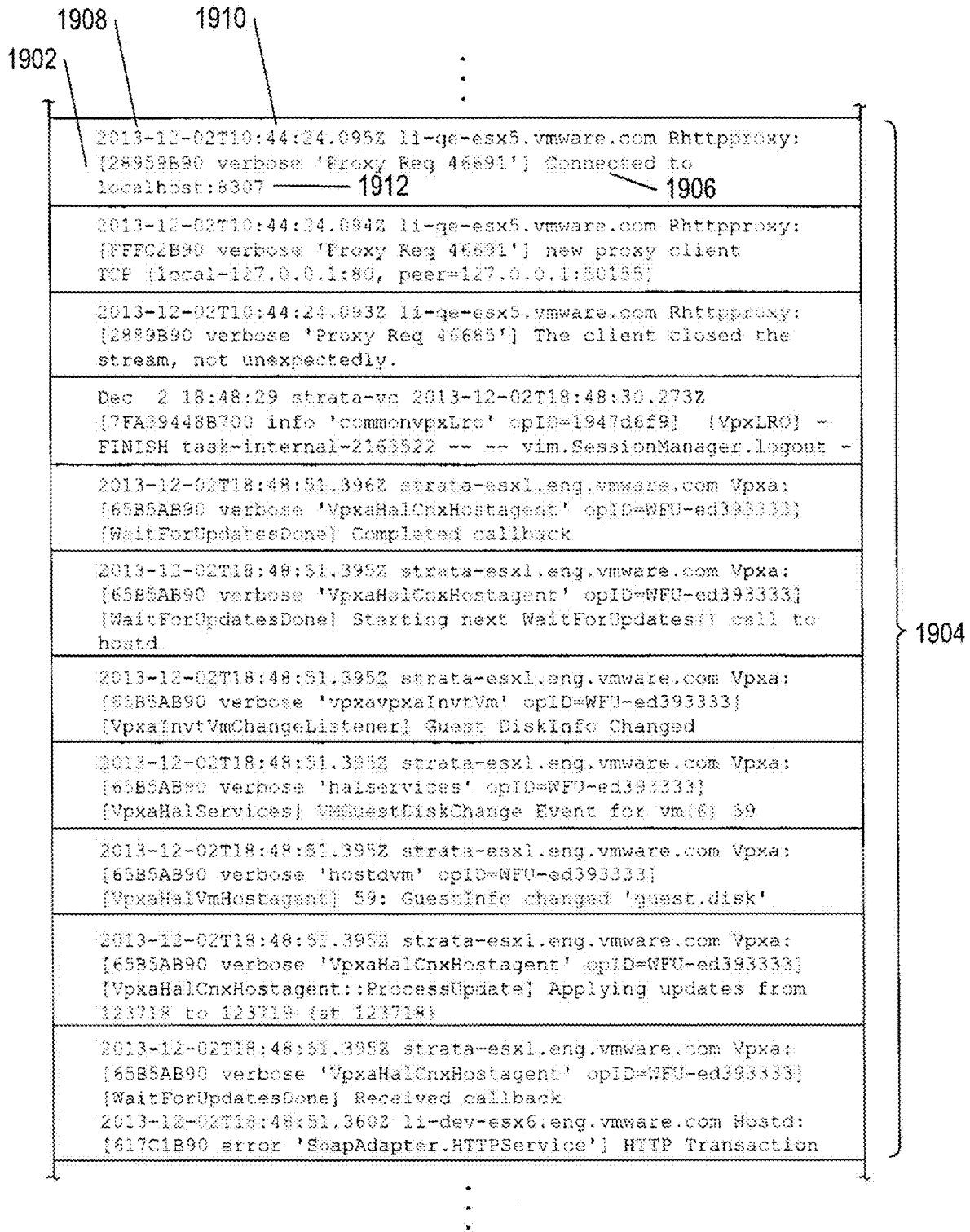
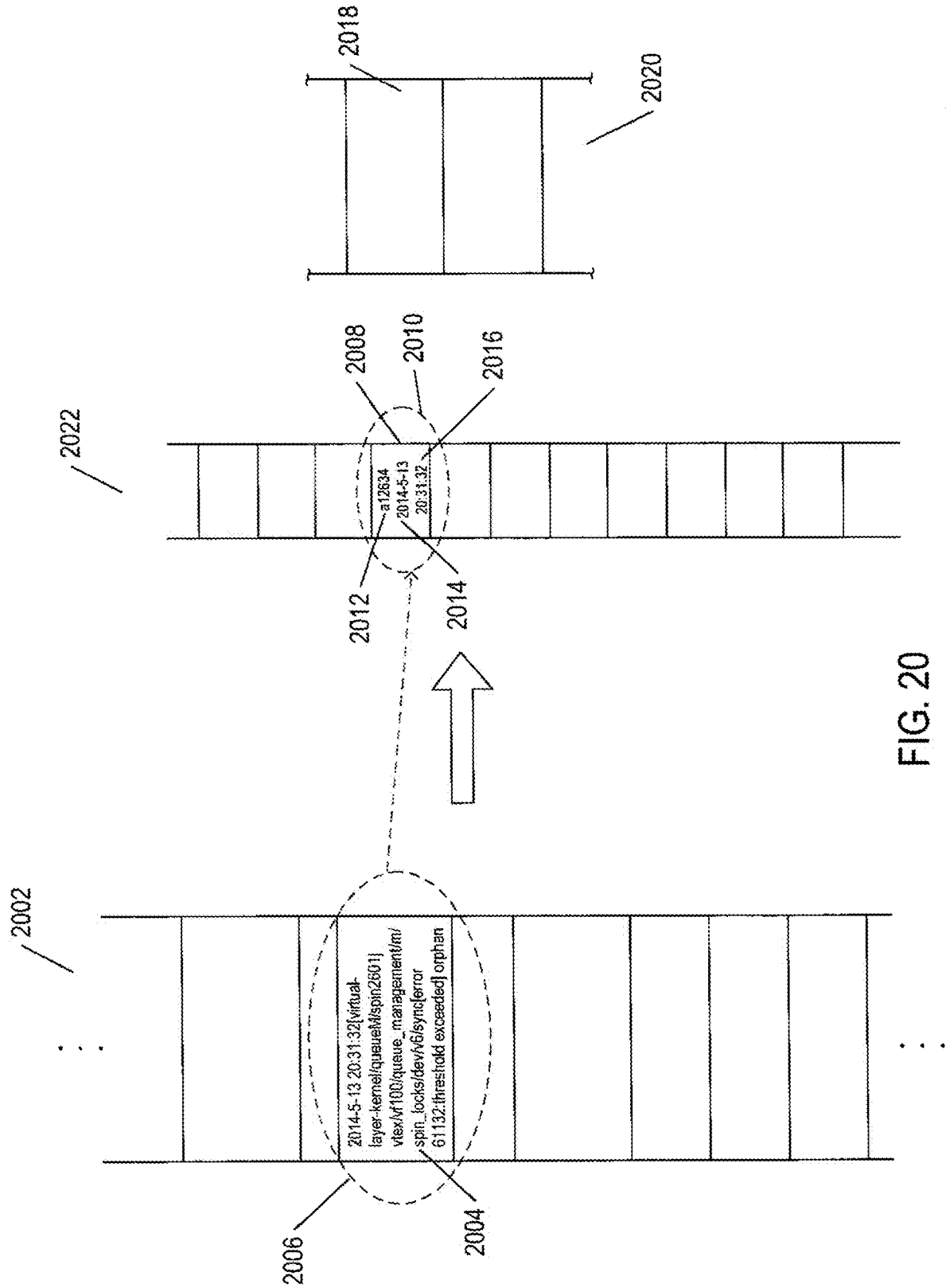

FIG. 19



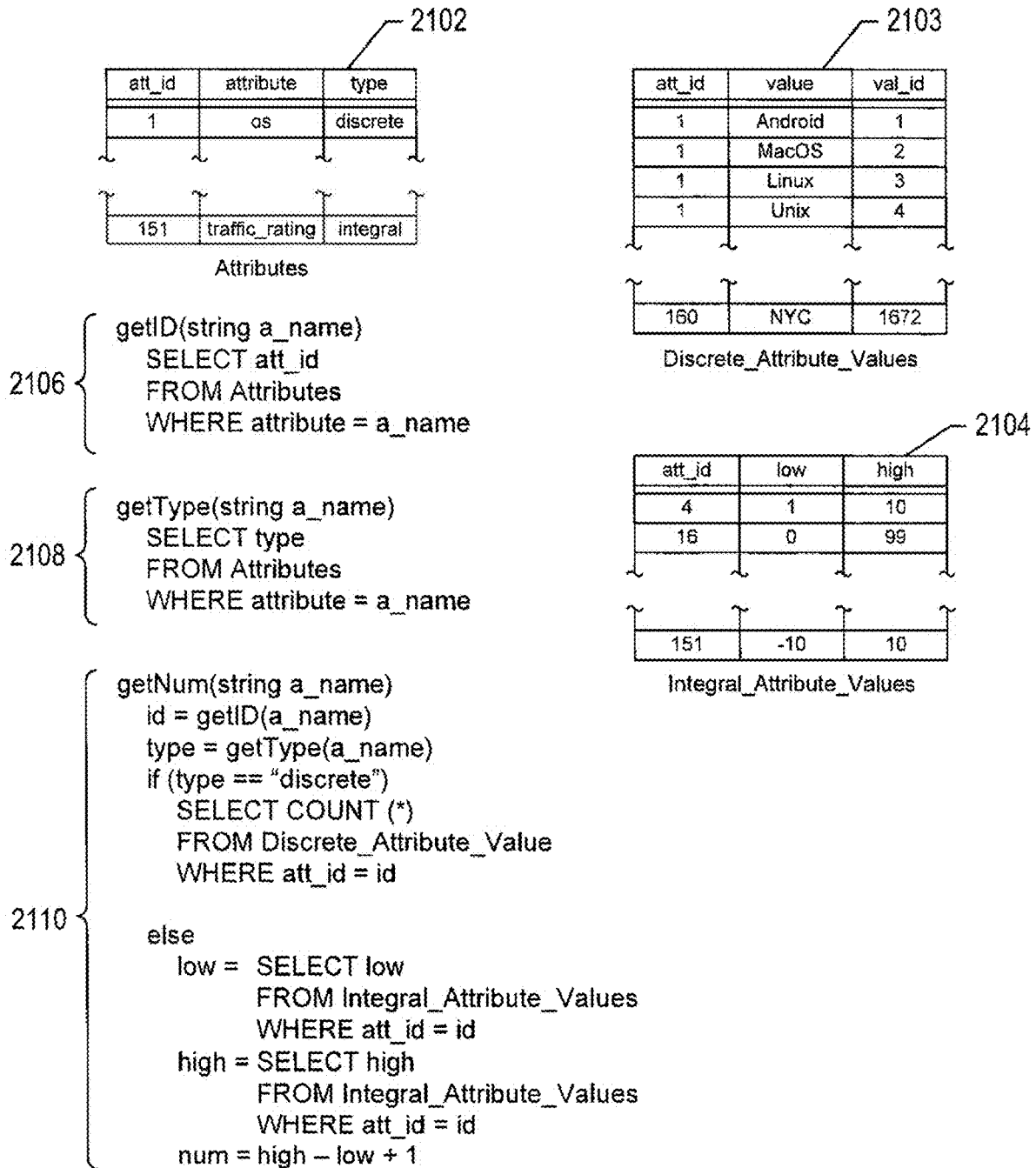

FIG. 21A

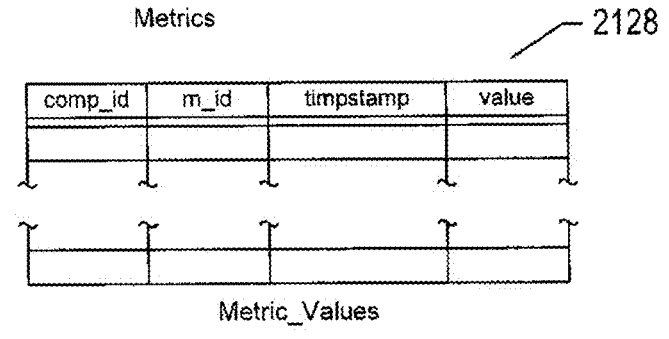
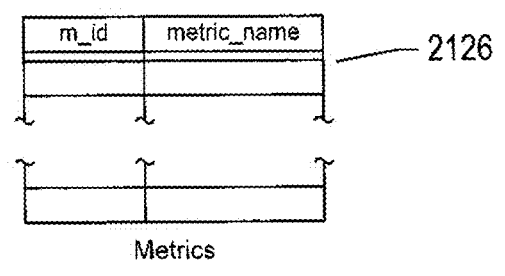
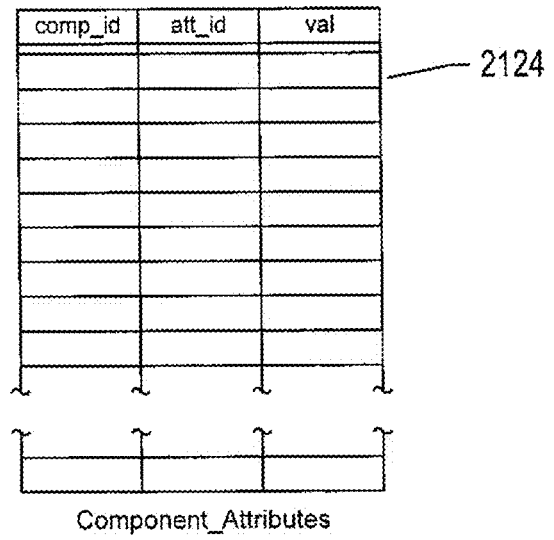
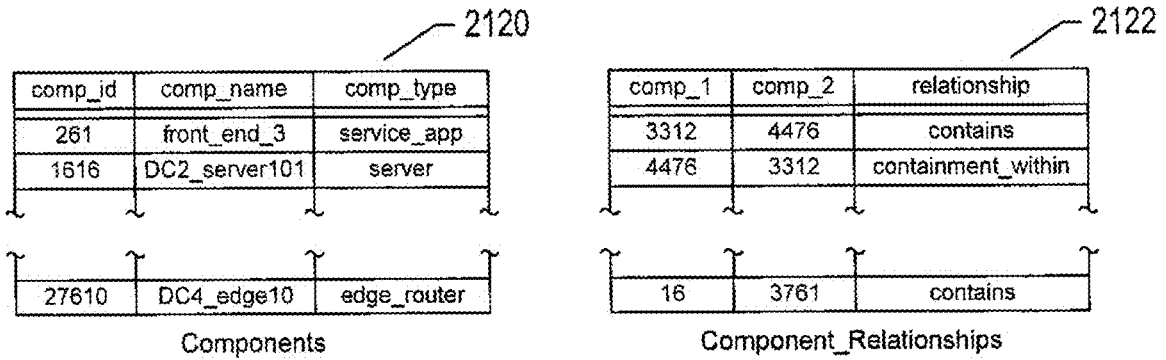

FIG. 21B

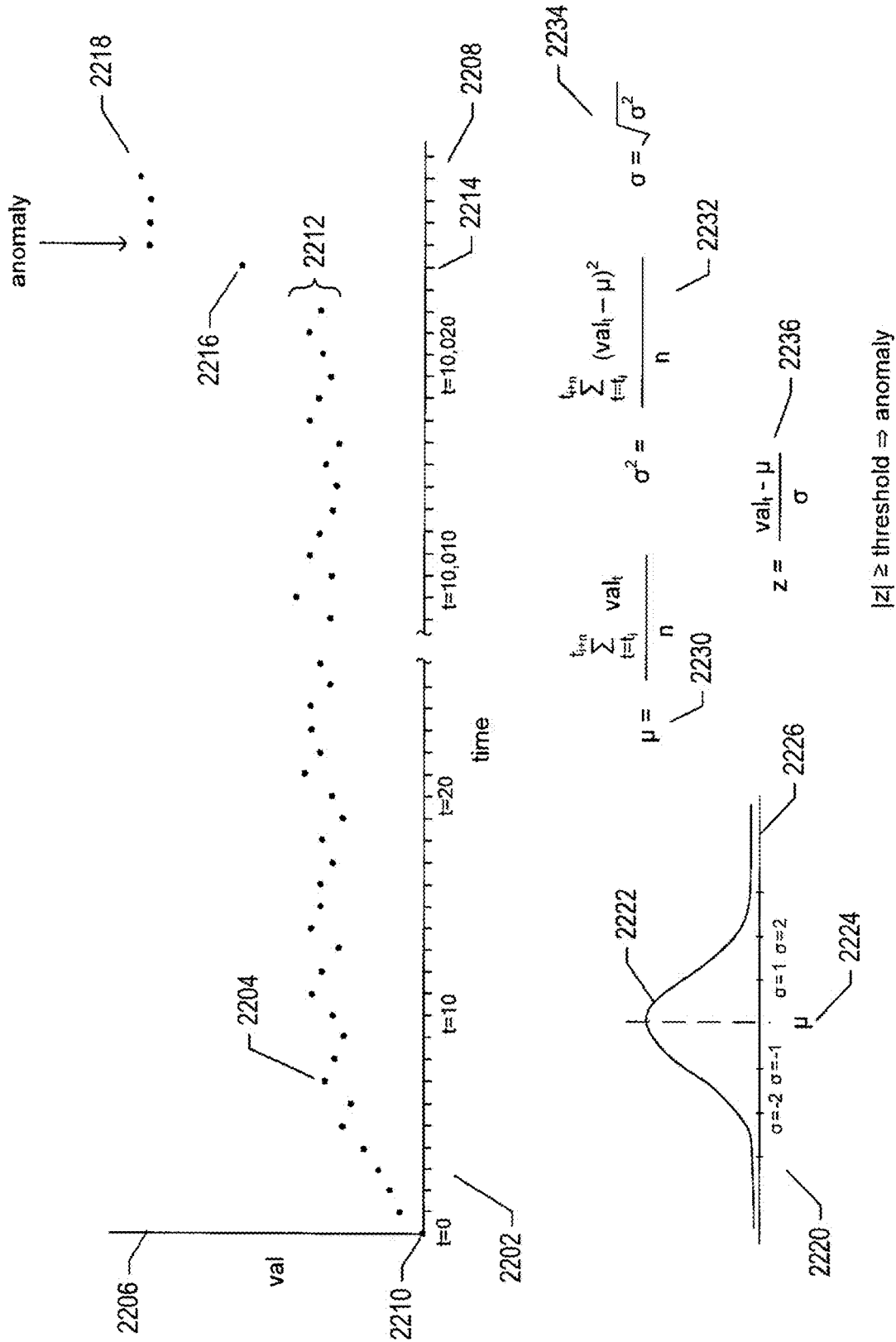

FIG. 22A

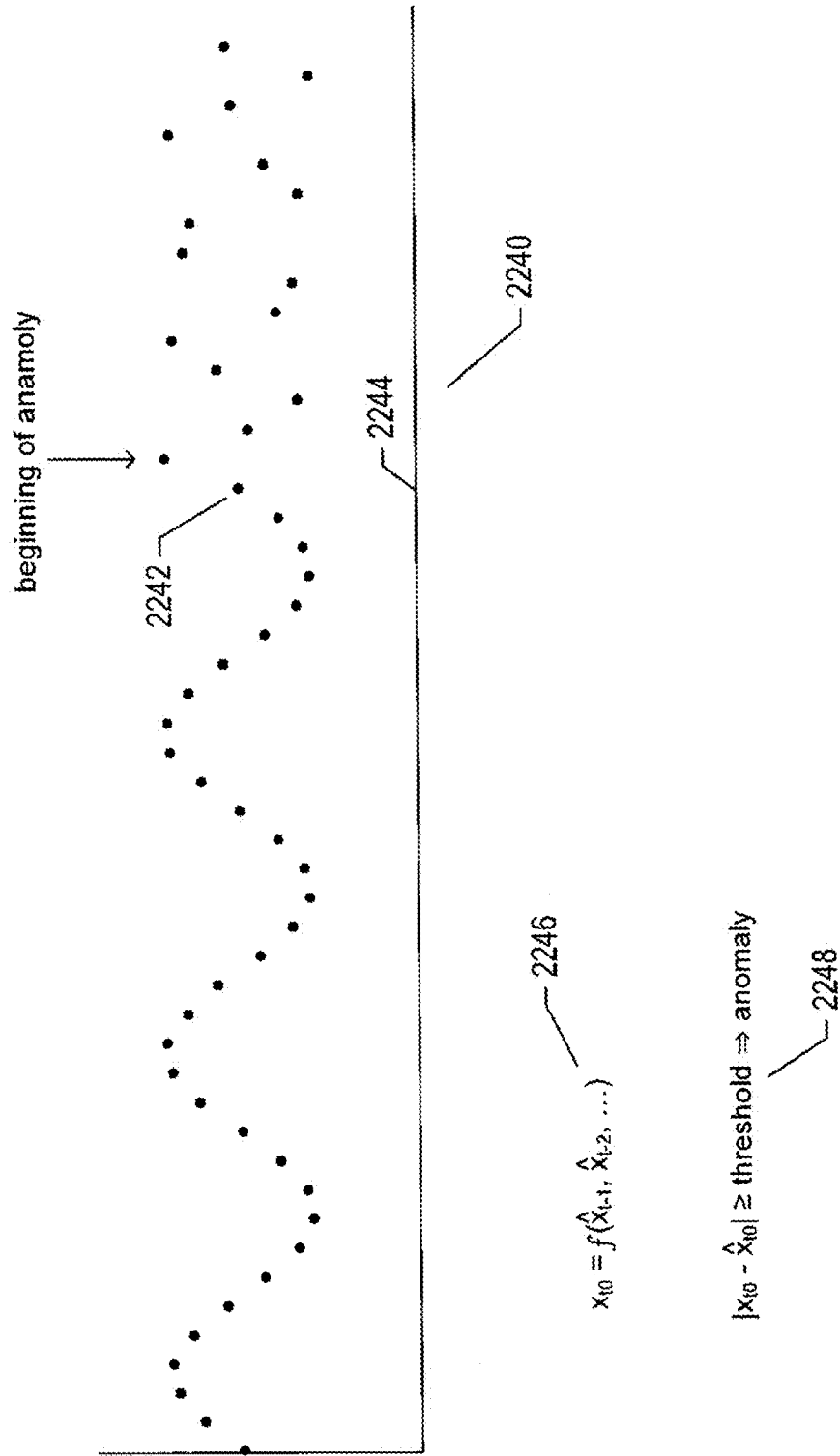

FIG. 22B



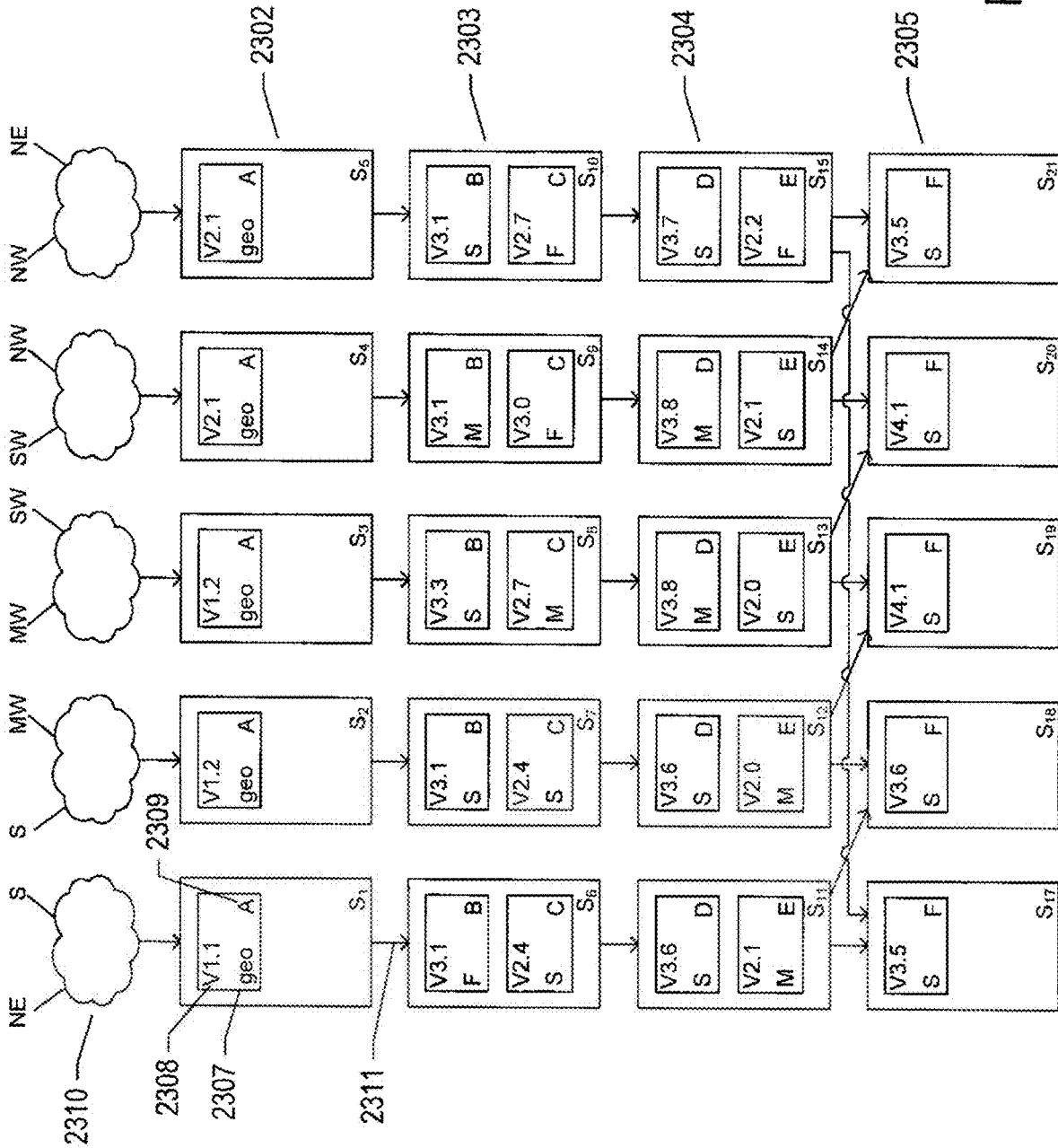

FIG. 23A

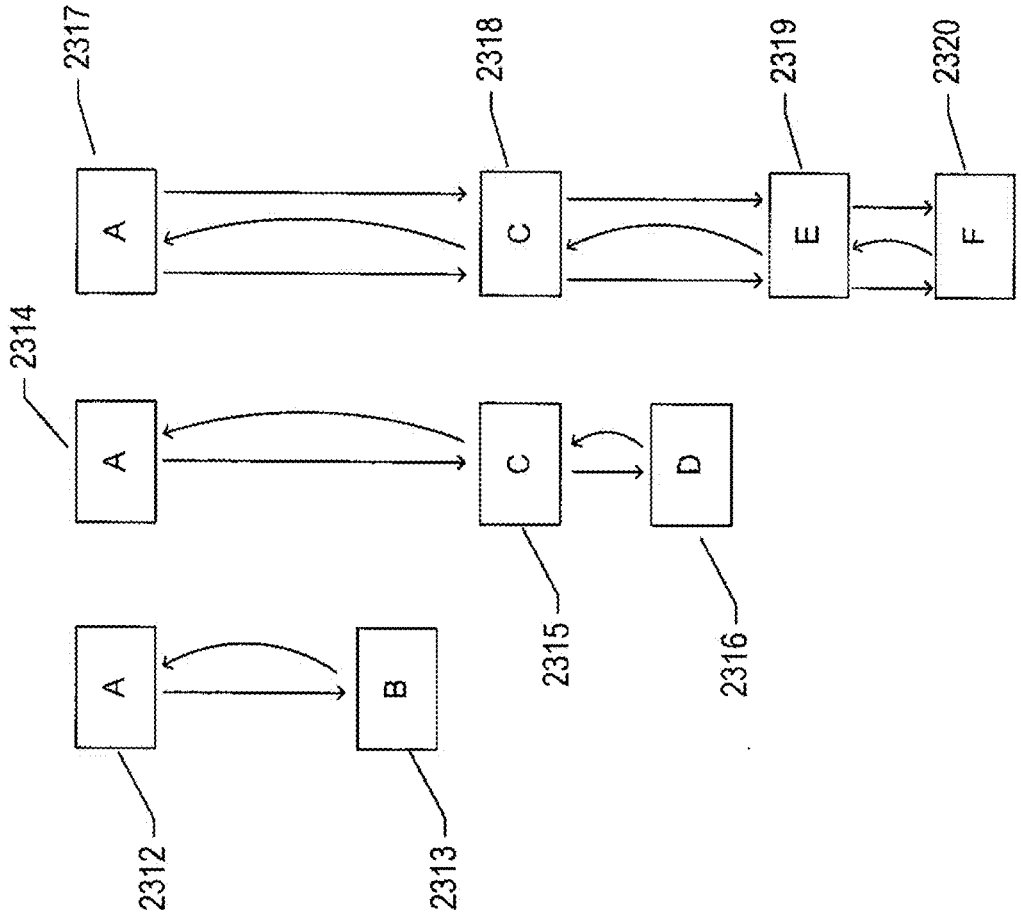

FIG. 23B

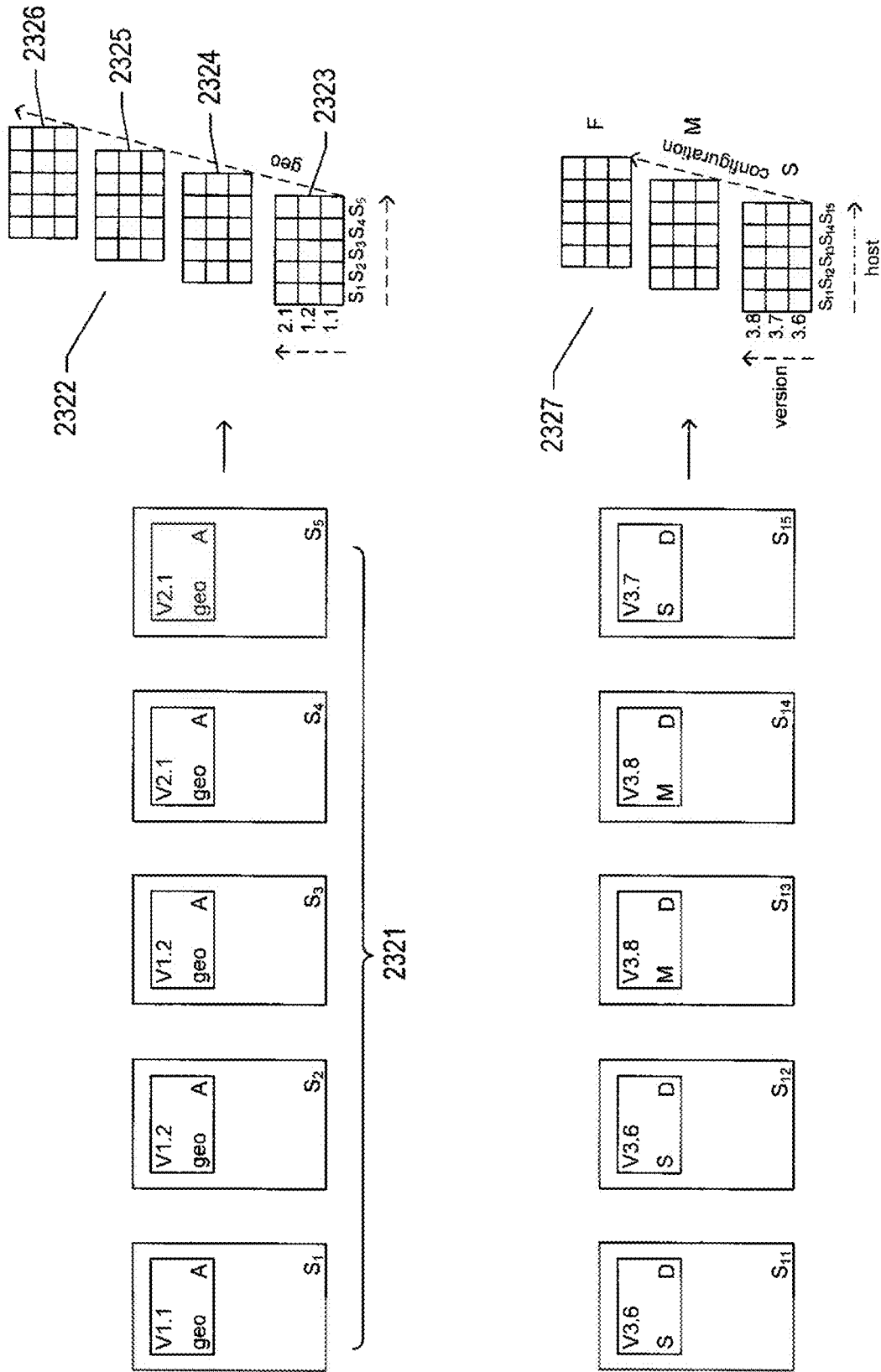

FIG. 23C

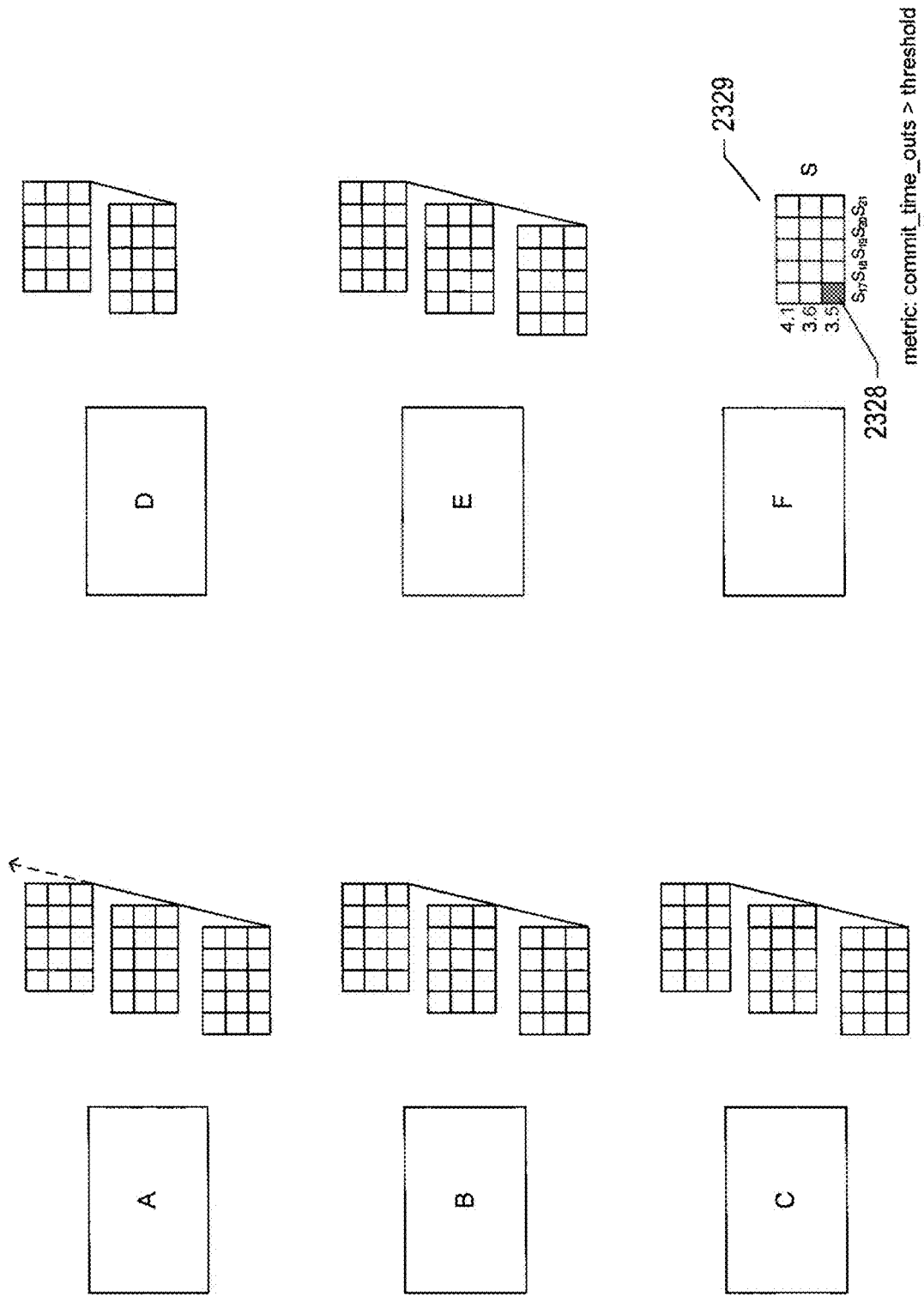

FIG. 23D

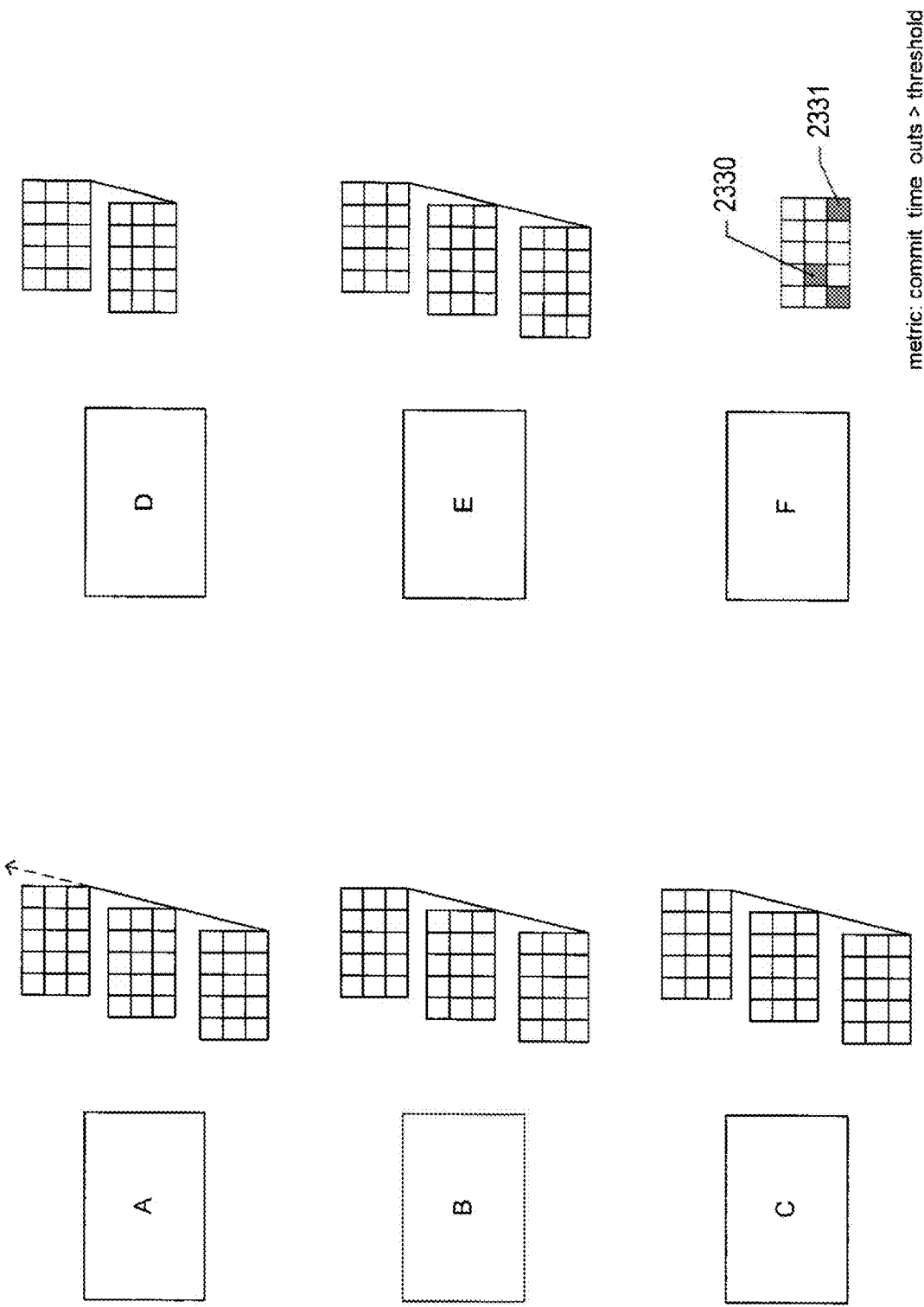

FIG. 23E

A			C			E			F		
host	geo	ver	host	conf	ver	host	conf	ver	host	conf	ver
S <sub>1</sub>	NE	1.1	S <sub>6</sub>	S	2.4	S <sub>11</sub>	M	2.1	S <sub>17</sub>	S	3.5
S <sub>2</sub>	S	1.2	S <sub>7</sub>	S	2.4	S <sub>12</sub>	M	2.0	S <sub>18</sub>	S	3.6
S <sub>5</sub>	NW	2.1	S <sub>10</sub>	F	2.7	S <sub>15</sub>	F	2.2	S <sub>17</sub>	S	3.5
S <sub>4</sub>	SW	2.1	S <sub>9</sub>	F	3.0	S <sub>14</sub>	S	2.1	S <sub>21</sub>	S	3.5
S <sub>1</sub>	S	1.1	S <sub>6</sub>	S	2.4	S <sub>11</sub>	M	2.1	S <sub>18</sub>	S	3.6
S <sub>5</sub>	NE	2.1	S <sub>10</sub>	F	2.7	S <sub>15</sub>	F	2.2	S <sub>21</sub>	S	3.5
S <sub>1</sub>	NE	1.1	S <sub>6</sub>	S	2.4	S <sub>11</sub>	M	2.1	S <sub>17</sub>	S	3.5
S <sub>2</sub>	MW	1.2	S <sub>7</sub>	S	2.4	S <sub>12</sub>	M	2.0	S <sub>18</sub>	S	3.6
S <sub>5</sub>	NW	2.1	S <sub>10</sub>	F	2.7	S <sub>15</sub>	F	2.2	S <sub>21</sub>	S	3.5
S <sub>2</sub>	S	1.2	S <sub>7</sub>	S	2.4	S <sub>12</sub>	M	2.0	S <sub>18</sub>	S	3.6
S <sub>1</sub>	S	1.1	S <sub>6</sub>	S	2.4	S <sub>11</sub>	M	2.1	S <sub>17</sub>	S	3.5
S <sub>5</sub>	NE	2.1	S <sub>10</sub>	F	2.7	S <sub>15</sub>	F	2.2	S <sub>17</sub>	S	3.5
S <sub>4</sub>	NW	2.1	S <sub>8</sub>	F	3.0	S <sub>14</sub>	S	2.1	S <sub>21</sub>	S	3.5
S <sub>1</sub>	NE	1.1	S <sub>6</sub>	S	2.4	S <sub>11</sub>	M	2.1	S <sub>18</sub>	S	3.6
S <sub>1</sub>	NE	1.1	S <sub>6</sub>	S	2.4	S <sub>11</sub>	M	2.1	S <sub>17</sub>	S	3.5
S <sub>5</sub>	NE	2.1	S <sub>10</sub>	F	2.7	S <sub>15</sub>	F	2.2	S <sub>21</sub>	S	3.5
S <sub>2</sub>	MW	1.2	S <sub>7</sub>	S	2.4	S <sub>12</sub>	M	2.0	S <sub>18</sub>	S	3.6
S <sub>1</sub>	S	1.1	S <sub>6</sub>	S	2.4	S <sub>11</sub>	M	2.1	S <sub>17</sub>	S	3.5
S <sub>5</sub>	NW	2.1	S <sub>10</sub>	F	2.7	S <sub>15</sub>	F	2.2	S <sub>21</sub>	S	3.5
S <sub>1</sub>	NE	1.1	S <sub>6</sub>	S	2.4	S <sub>11</sub>	M	2.1	S <sub>18</sub>	S	3.6
S <sub>4</sub>	SW	2.1	S <sub>9</sub>	F	3.0	S <sub>14</sub>	M	2.1	S <sub>17</sub>	S	3.5
S <sub>2</sub>	S	1.2	S <sub>7</sub>	S	2.4	S <sub>12</sub>	M	2.0	S <sub>18</sub>	S	3.6
S <sub>1</sub>	S	1.1	S <sub>6</sub>	S	2.4	S <sub>11</sub>	M	2.1	S <sub>17</sub>	S	3.5
S <sub>5</sub>	NE	2.1	S <sub>10</sub>	F	2.7	S <sub>15</sub>	F	2.2	S <sub>21</sub>	S	3.5

FIG. 23F

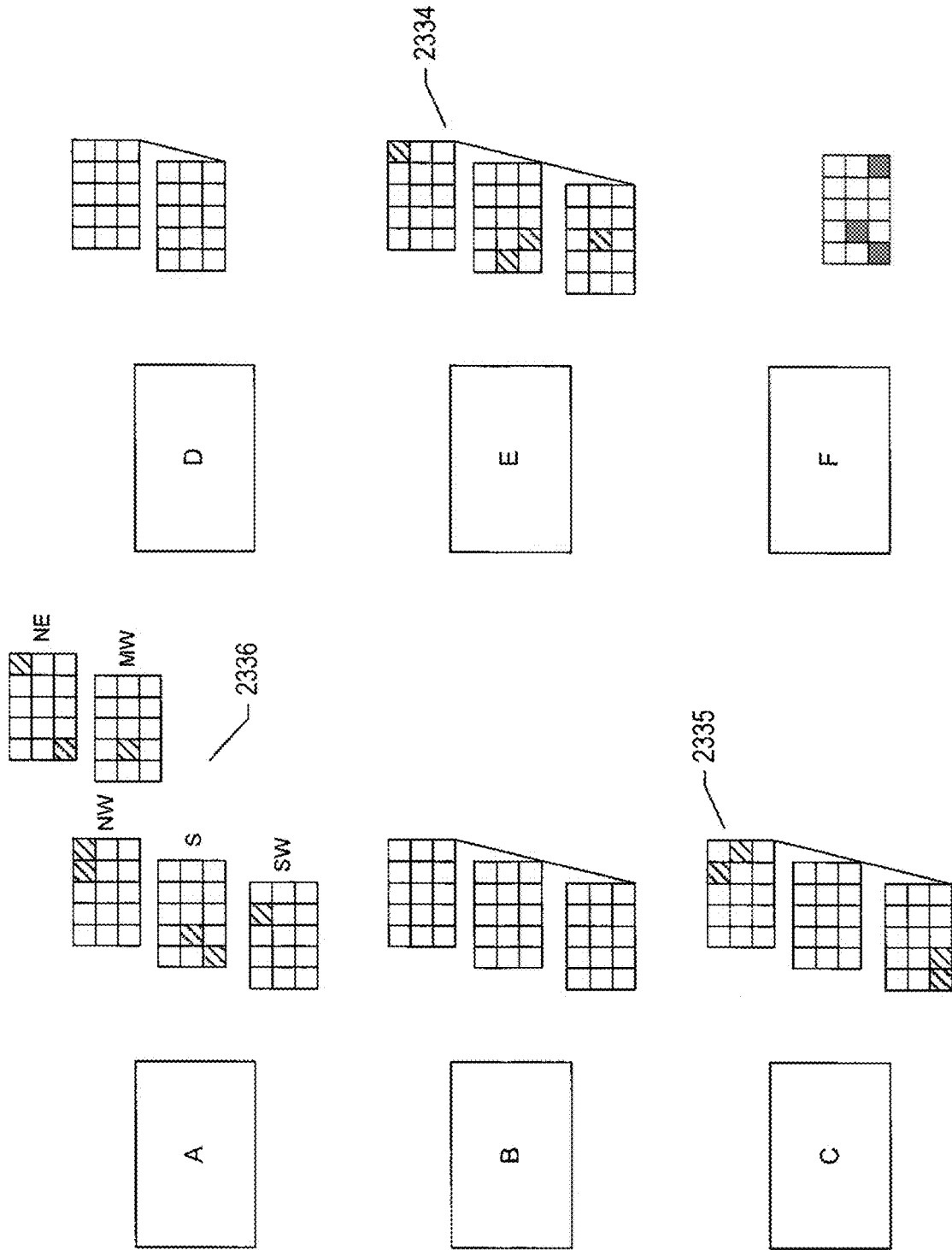

FIG. 23G

A			B			C			D			E			F		
host	geo	ver	host	conf	ver	host	conf	ver	host	conf	ver	host	conf	ver	host	conf	ver
S <sub>3</sub>	MW	1.2	S <sub>8</sub>	S	3.3	S <sub>6</sub>	S	2.4									
S <sub>1</sub>	NE	1.1				S <sub>8</sub>	M	2.7							S <sub>17</sub>	S	3.5
S <sub>3</sub>	SW	1.2				S <sub>9</sub>	F	3.0							S <sub>20</sub>	S	4.1
S <sub>4</sub>	NW	2.1				S <sub>7</sub>	S	2.4	S <sub>14</sub>	M	3.8						
S <sub>2</sub>	S	1.2				S <sub>6</sub>	S	2.4									
S <sub>1</sub>	NE	1.1				S <sub>6</sub>	S	2.4	S <sub>11</sub>	S	3.6				S <sub>18</sub>	S	3.6
S <sub>4</sub>	NW	2.1			3.1	S <sub>7</sub>	S	2.4									
S <sub>2</sub>	S	1.2				S <sub>10</sub>	F	2.7	S <sub>12</sub>	S	3.6				S <sub>17</sub>	S	3.5
S <sub>5</sub>	NW	2.1				S <sub>7</sub>	F	2.7									
S <sub>2</sub>	S	1.2				S <sub>7</sub>	F	2.7									
S <sub>4</sub>	SW	2.1				S <sub>9</sub>	F	3.0									
S <sub>3</sub>	MW	1.2				S <sub>8</sub>	M	2.7							S <sub>21</sub>	S	3.5
S <sub>1</sub>	S	1.1				S <sub>8</sub>	M	2.7							S <sub>19</sub>	S	4.1
S <sub>2</sub>	MW	1.2				S <sub>6</sub>	S	2.4							S <sub>18</sub>	S	3.6
S <sub>5</sub>	NE	2.1				S <sub>7</sub>	S	2.4							S <sub>19</sub>	S	3.6
S <sub>5</sub>	NE	2.1			3.1	S <sub>10</sub>	F	2.7							S <sub>18</sub>	S	3.6
S <sub>4</sub>	SW	2.1				S <sub>10</sub>	F	2.7							S <sub>21</sub>	S	3.5
S <sub>3</sub>	MW	1.2			3.1	S <sub>8</sub>	M	2.7									
S <sub>1</sub>	NE	1.1				S <sub>6</sub>	S	2.4	S <sub>13</sub>	M	3.8				S <sub>17</sub>	S	3.5
S <sub>5</sub>	NW	2.1				S <sub>10</sub>	F	2.7	S <sub>15</sub>	S	3.7						
S <sub>2</sub>	S	1.2			3.1	S <sub>7</sub>	S	2.4									
S <sub>2</sub>	MW	1.2				S <sub>7</sub>	S	2.4									
S <sub>1</sub>	S	1.1			3.1	S <sub>6</sub>	F	2.4									
S <sub>2</sub>	S	1.2			2.4	S <sub>7</sub>	S	2.0									
S <sub>5</sub>	NW	2.1				S <sub>12</sub>	M	2.7									
S <sub>3</sub>	SW	1.2			3.3	S <sub>10</sub>	F	2.7							S <sub>15</sub>	F	2.2
S <sub>1</sub>	S	1.1				S <sub>6</sub>	S	2.4									
S <sub>2</sub>	MW	1.2			3.1	S <sub>7</sub>	S	3.0	S <sub>11</sub>	M	2.1						
S <sub>4</sub>	SW	2.1				S <sub>9</sub>	F	3.0							S <sub>20</sub>	S	4.1
S <sub>4</sub>	NW	2.1			3.1	S <sub>9</sub>	F	3.0							S <sub>21</sub>	S	3.5
S <sub>5</sub>	NE	2.1				S <sub>9</sub>	F	3.0									

FIG. 23H



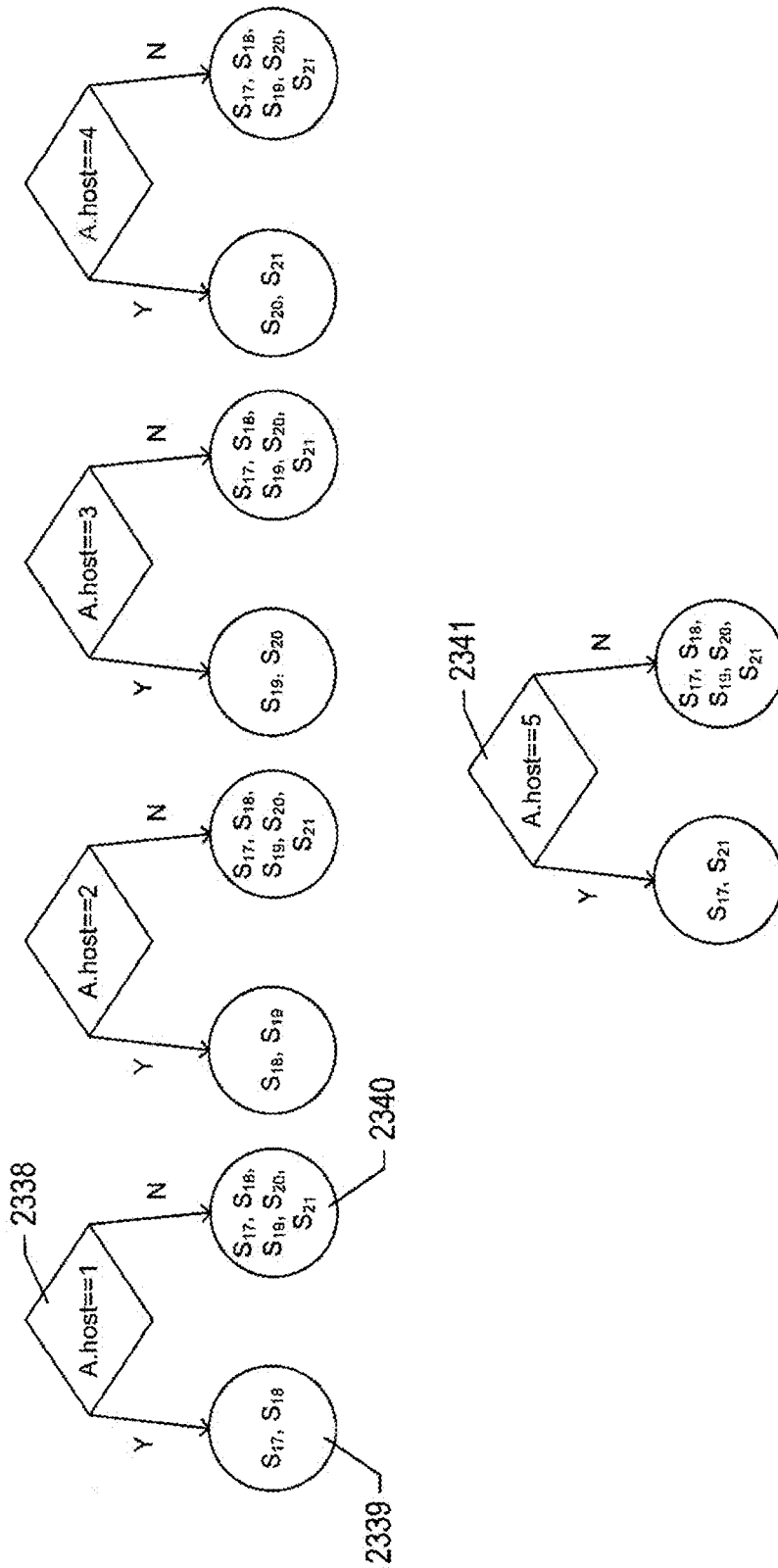

FIG. 23I

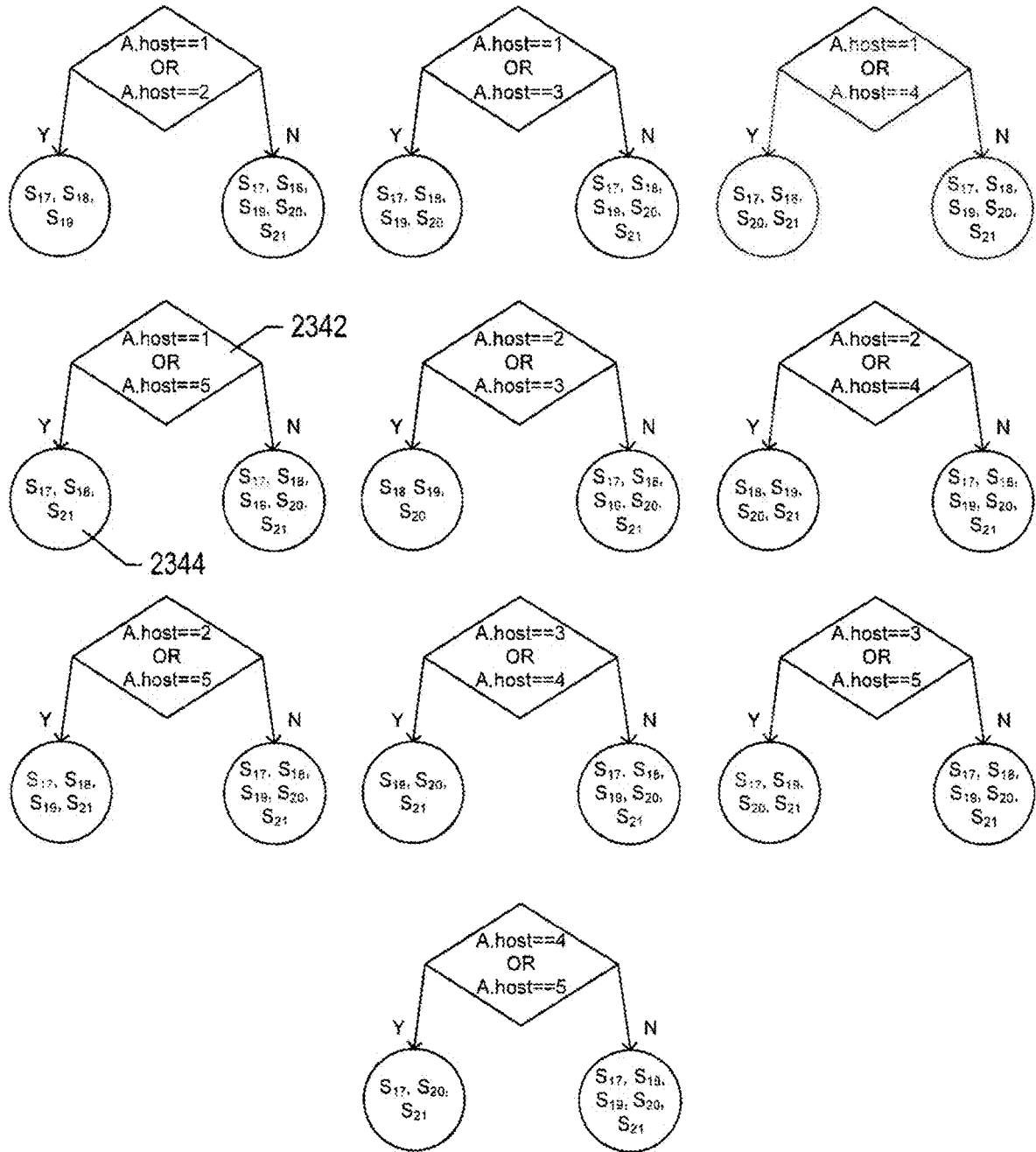

FIG. 23J

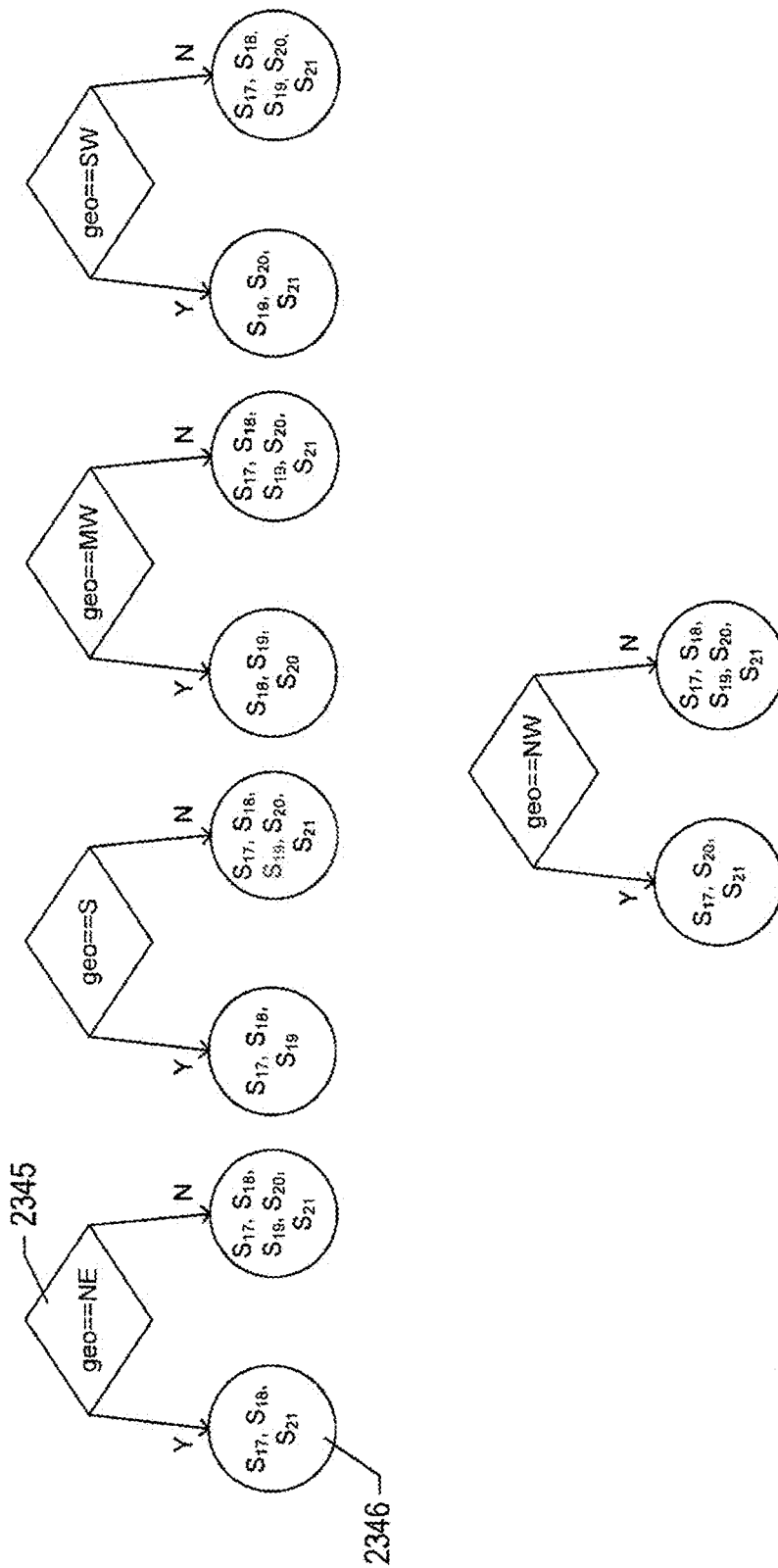

FIG. 23K

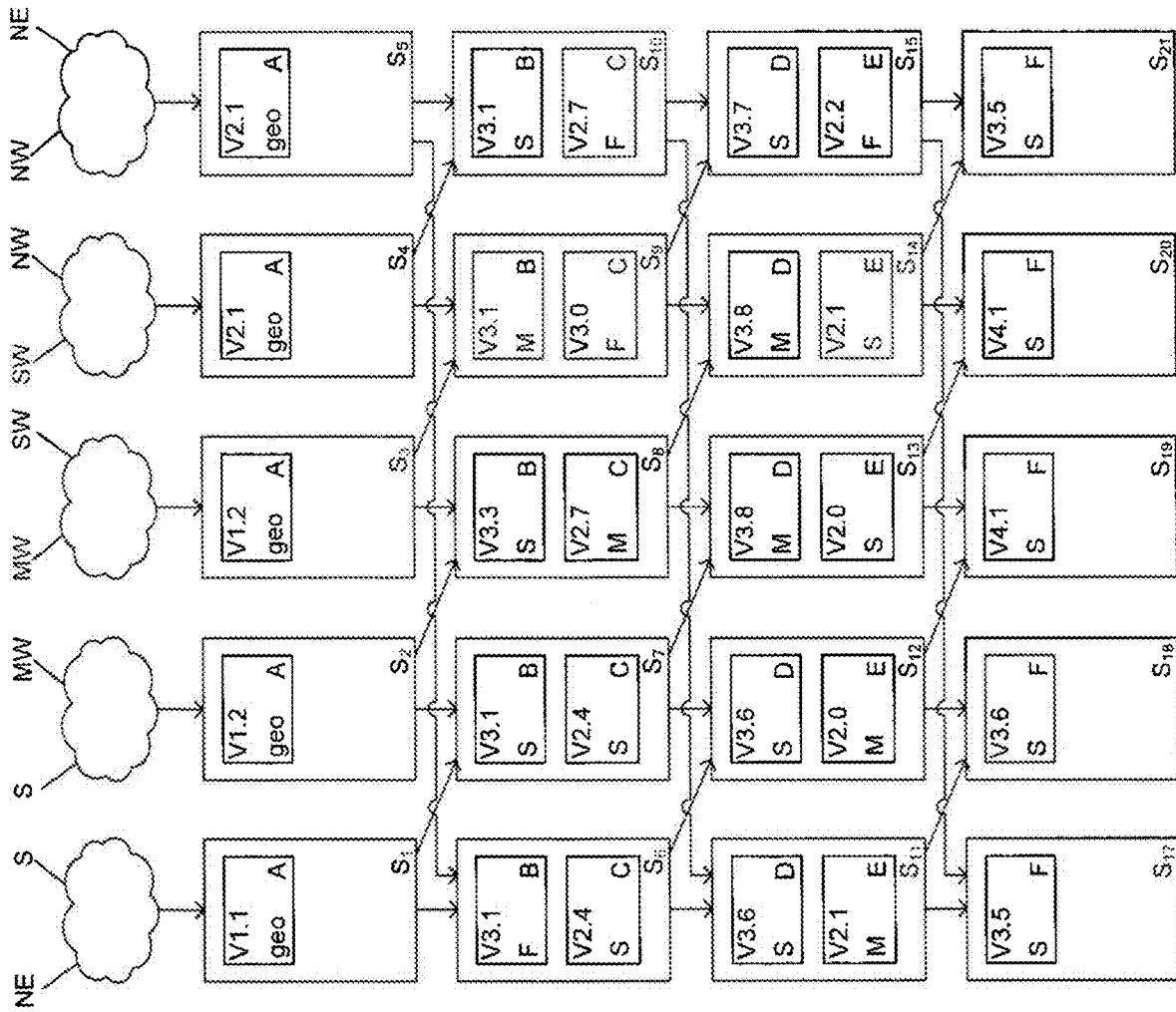

FIG. 24A

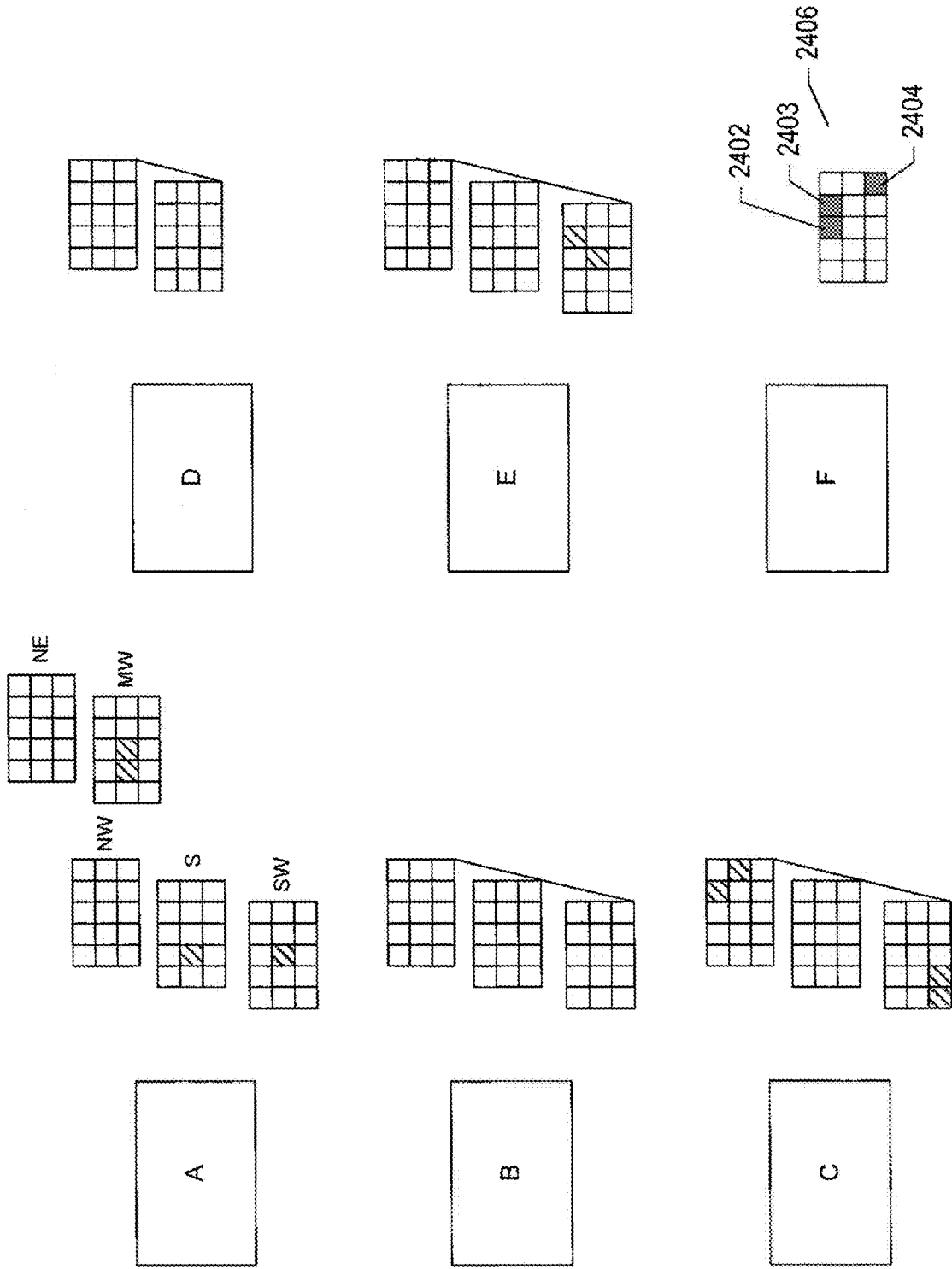

FIG. 24B

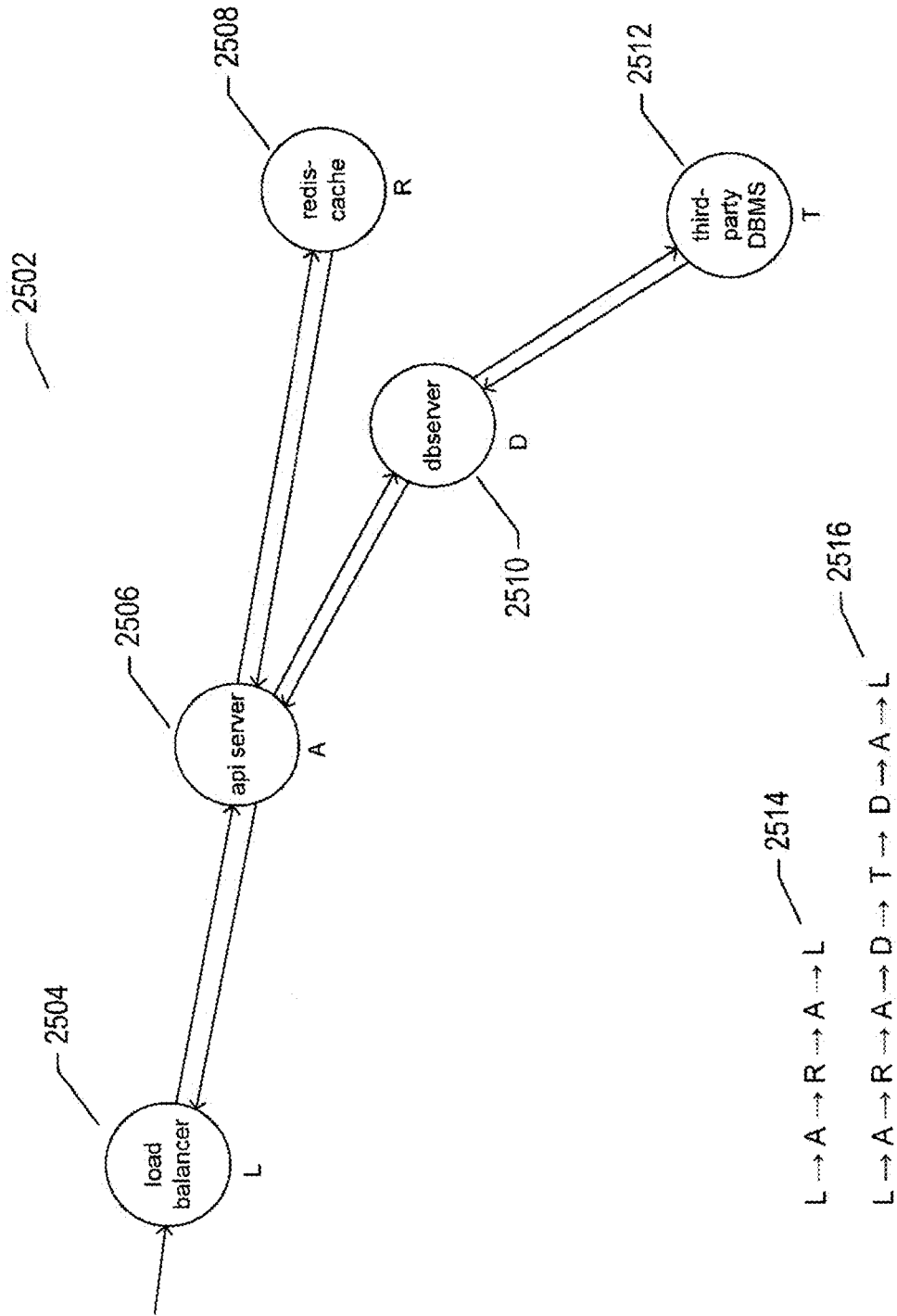

FIG. 25A

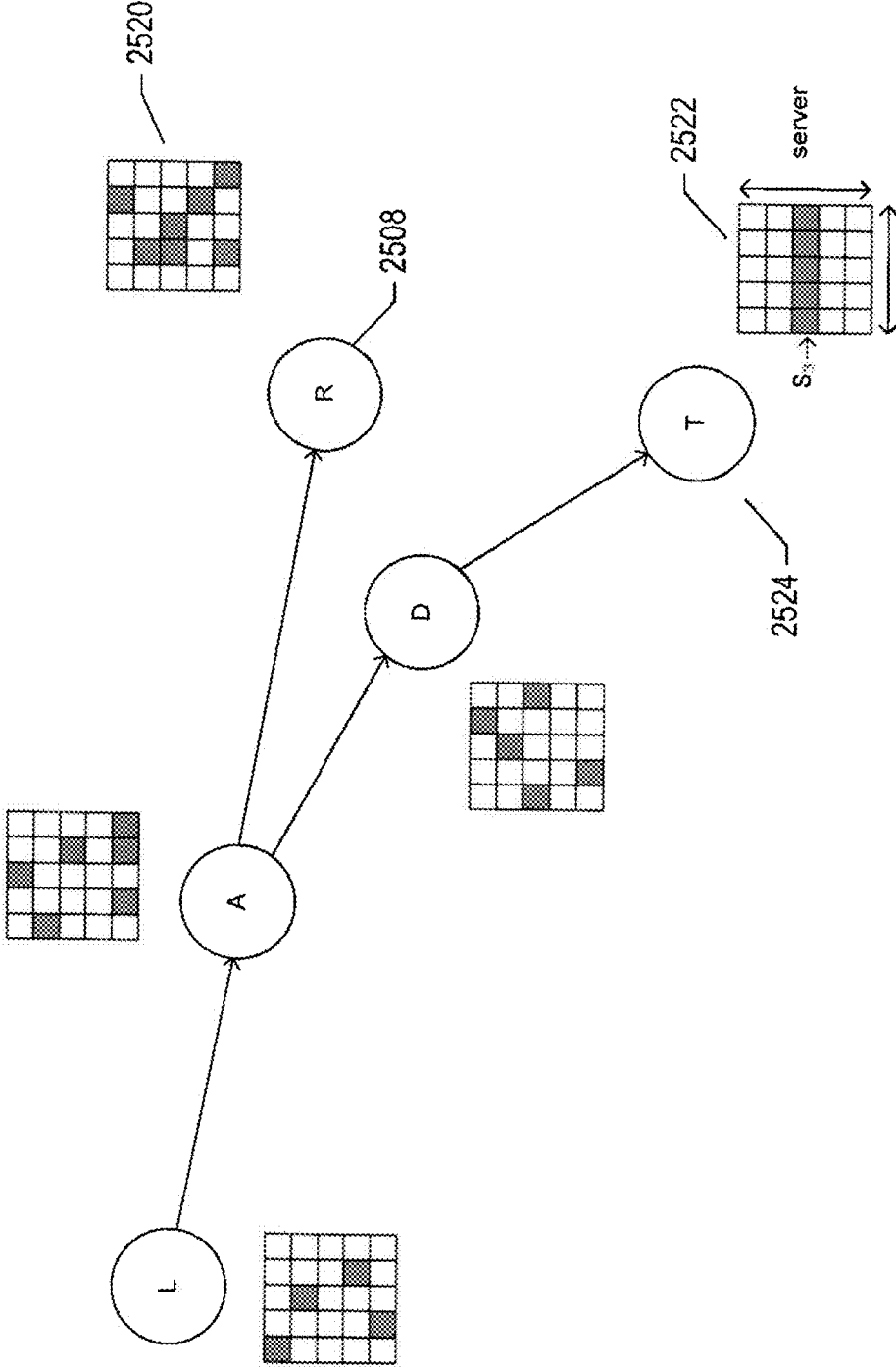

FIG. 25B

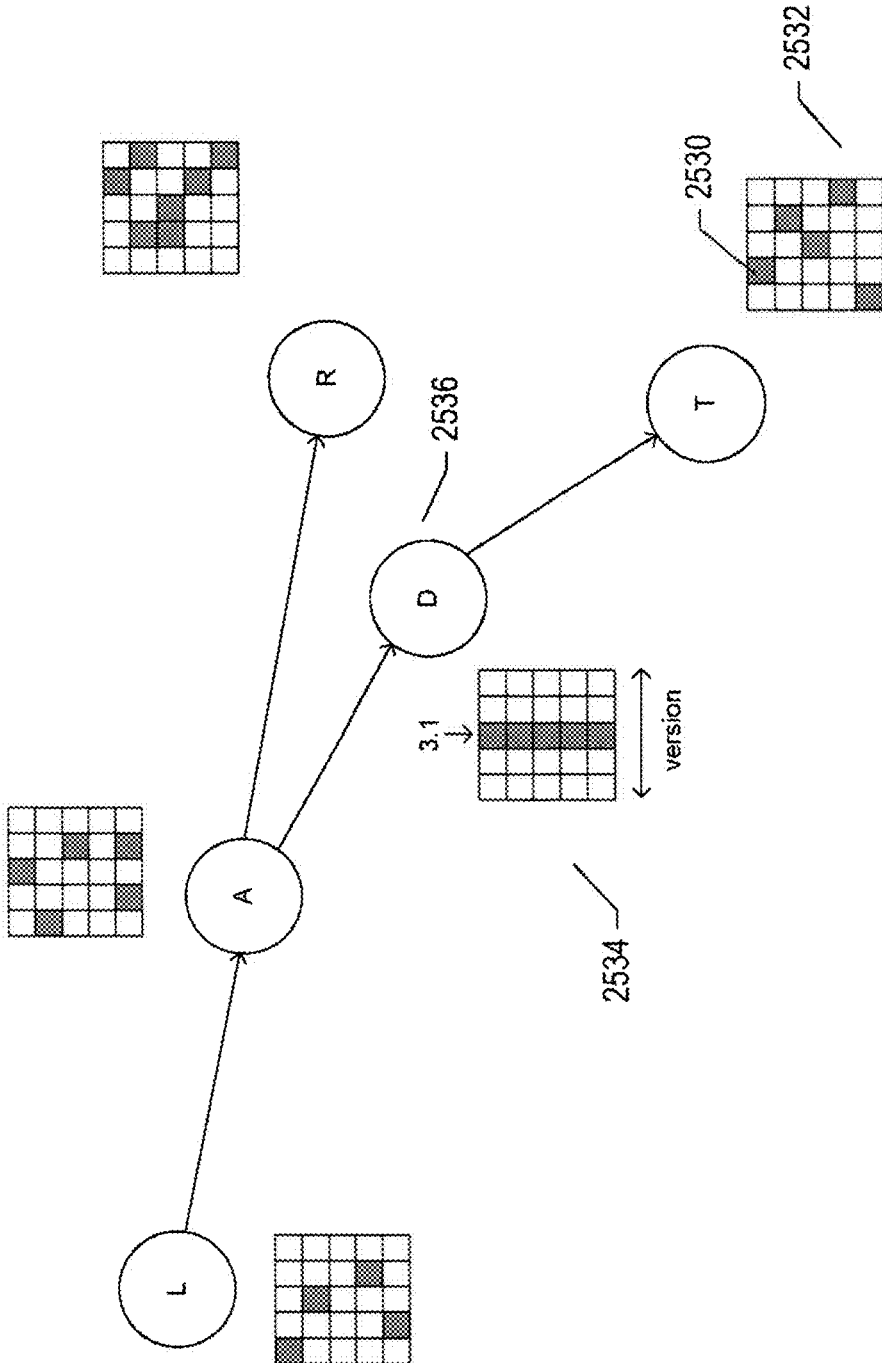

FIG. 25C



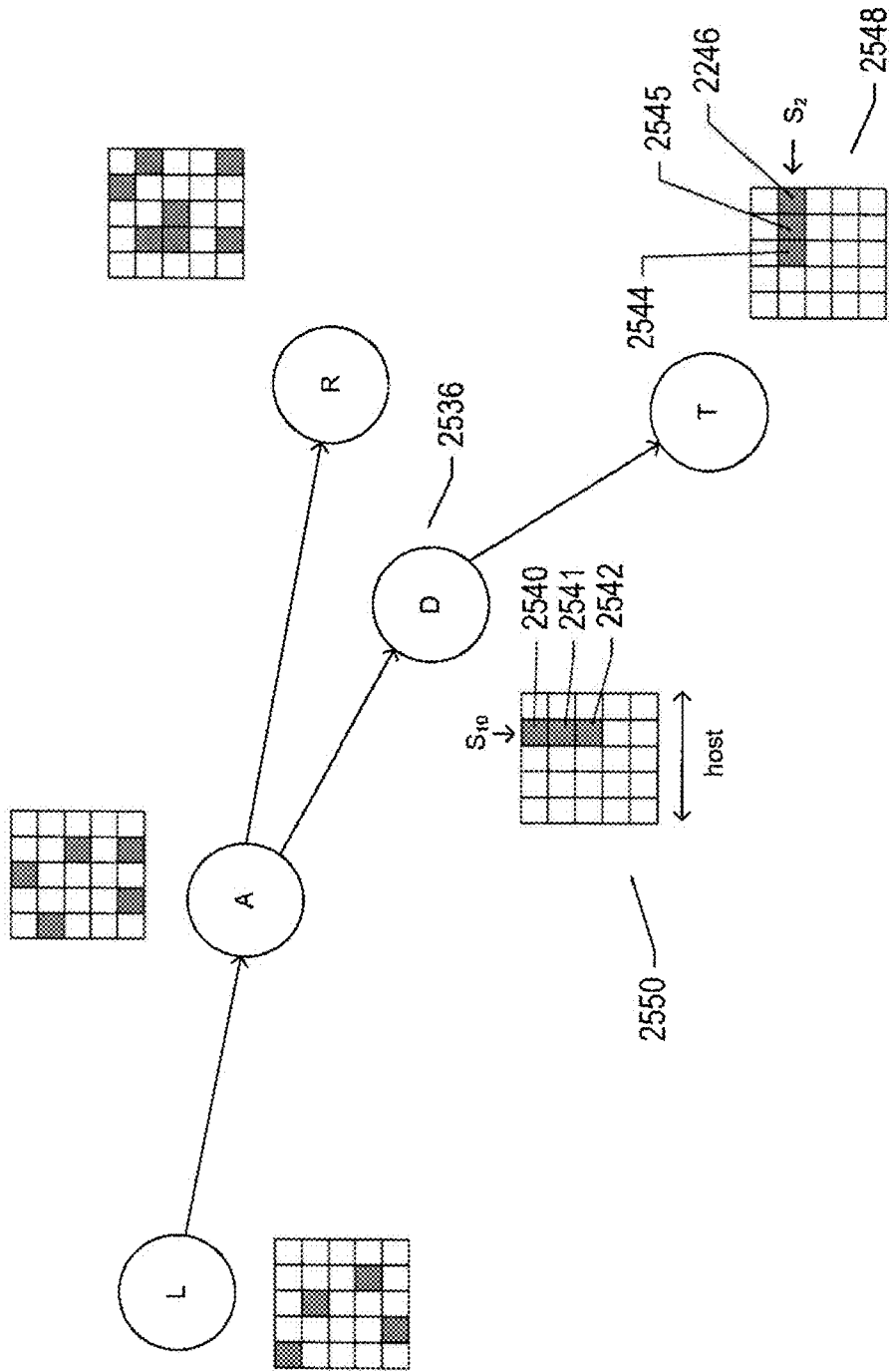

FIG. 25D

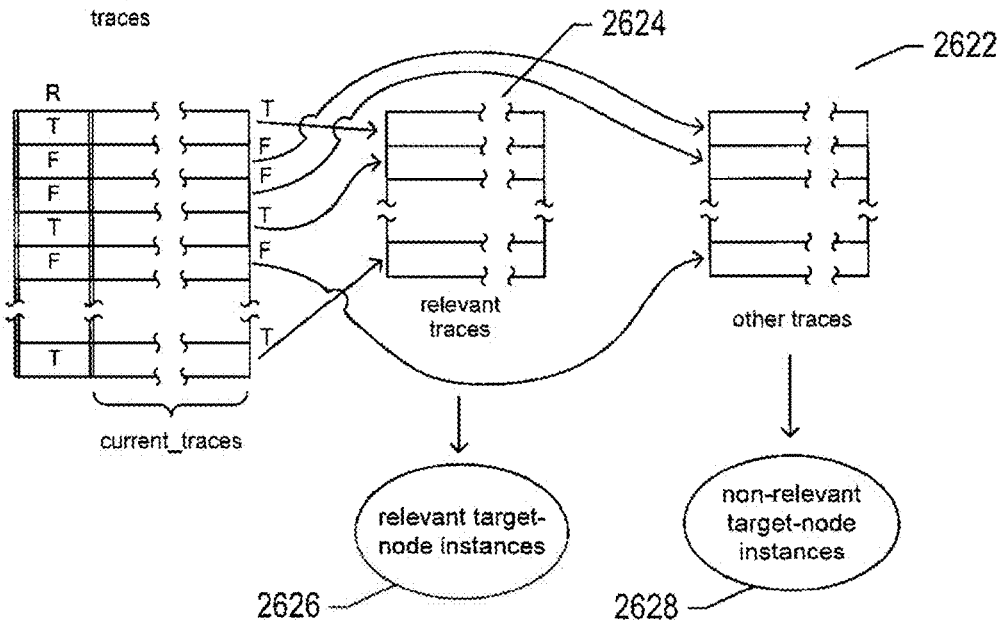
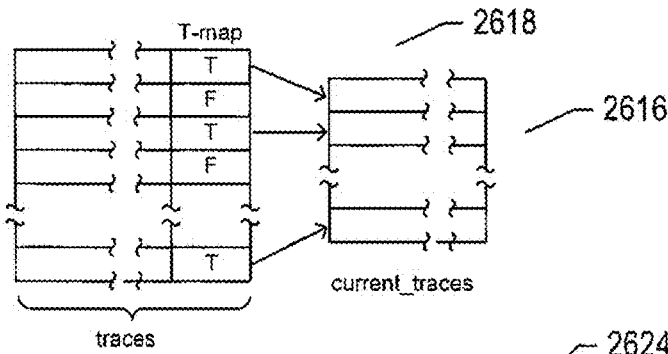
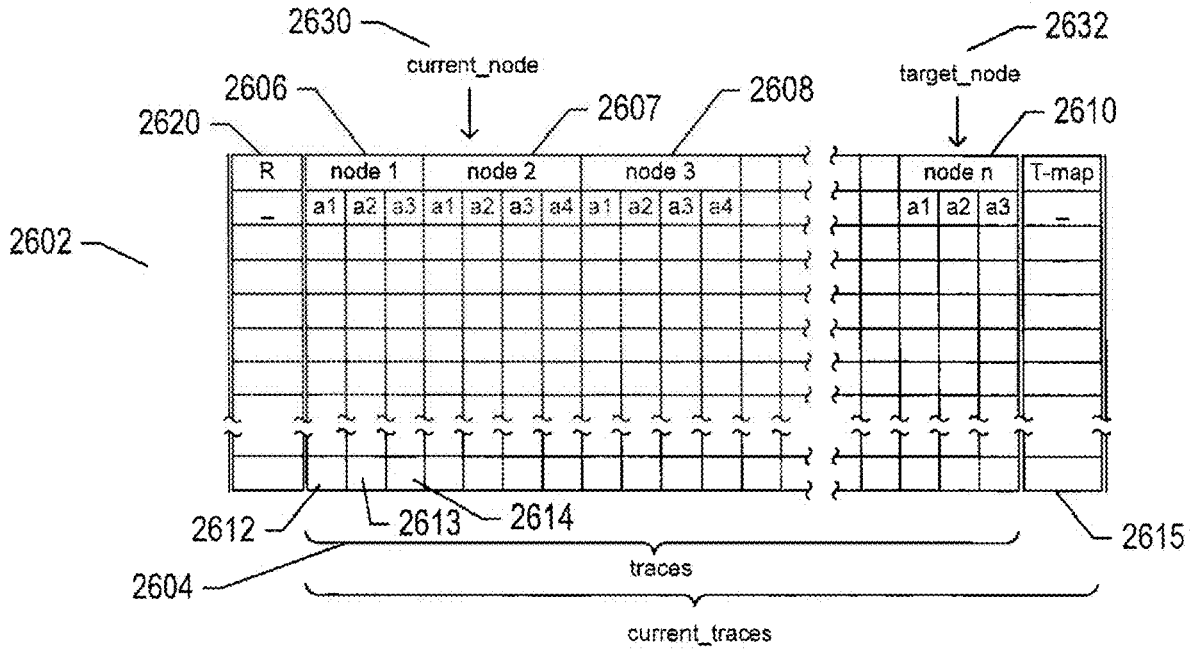
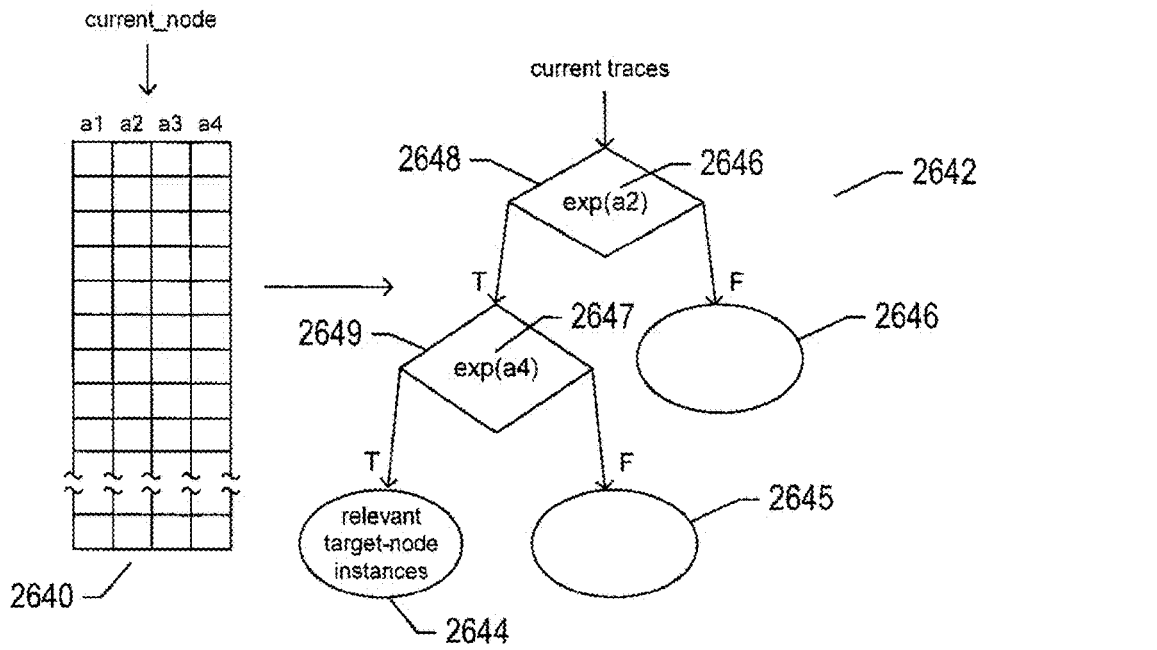

FIG. 26A



$$\text{exp}(a_i) = (a_i == a_{i1} \text{ OR } a_i == a_{i2} \text{ OR } \dots \text{ OR } a_i == a_{i2})$$

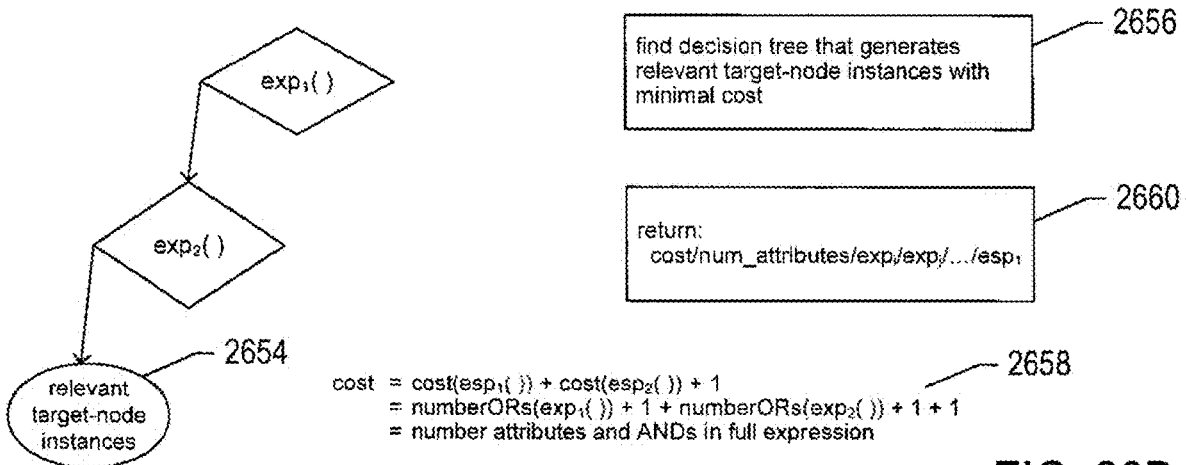
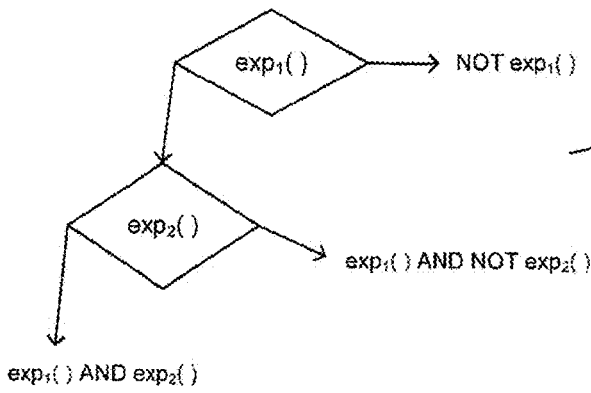

FIG. 26B

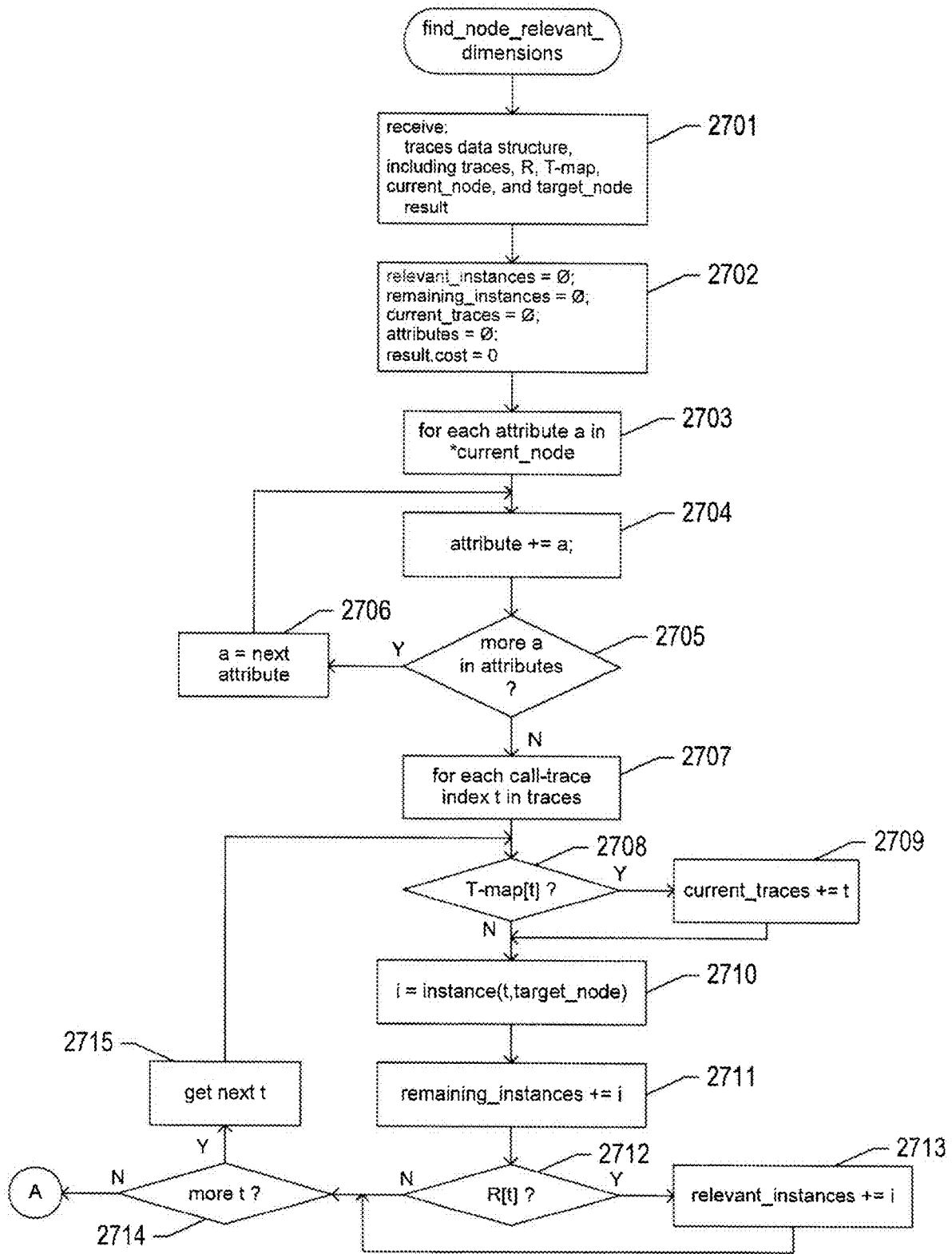

FIG. 27A

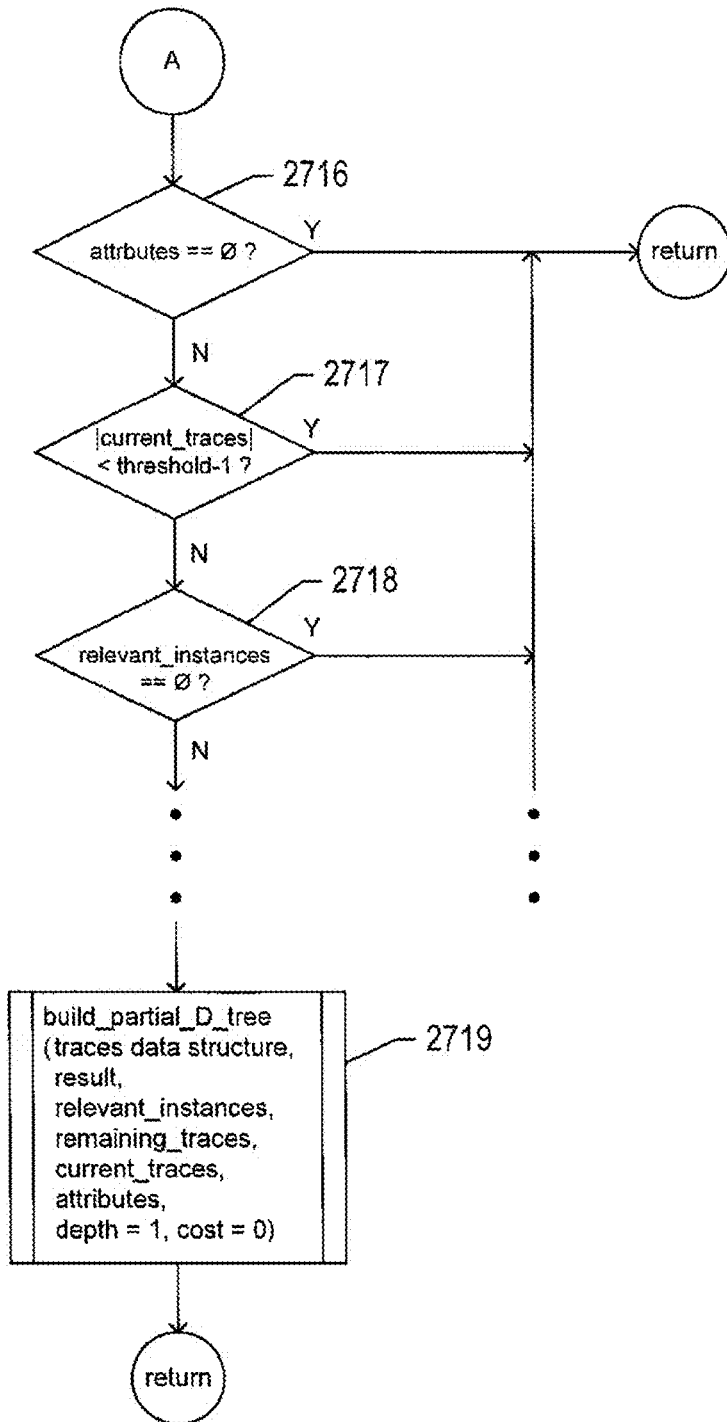

FIG. 27B

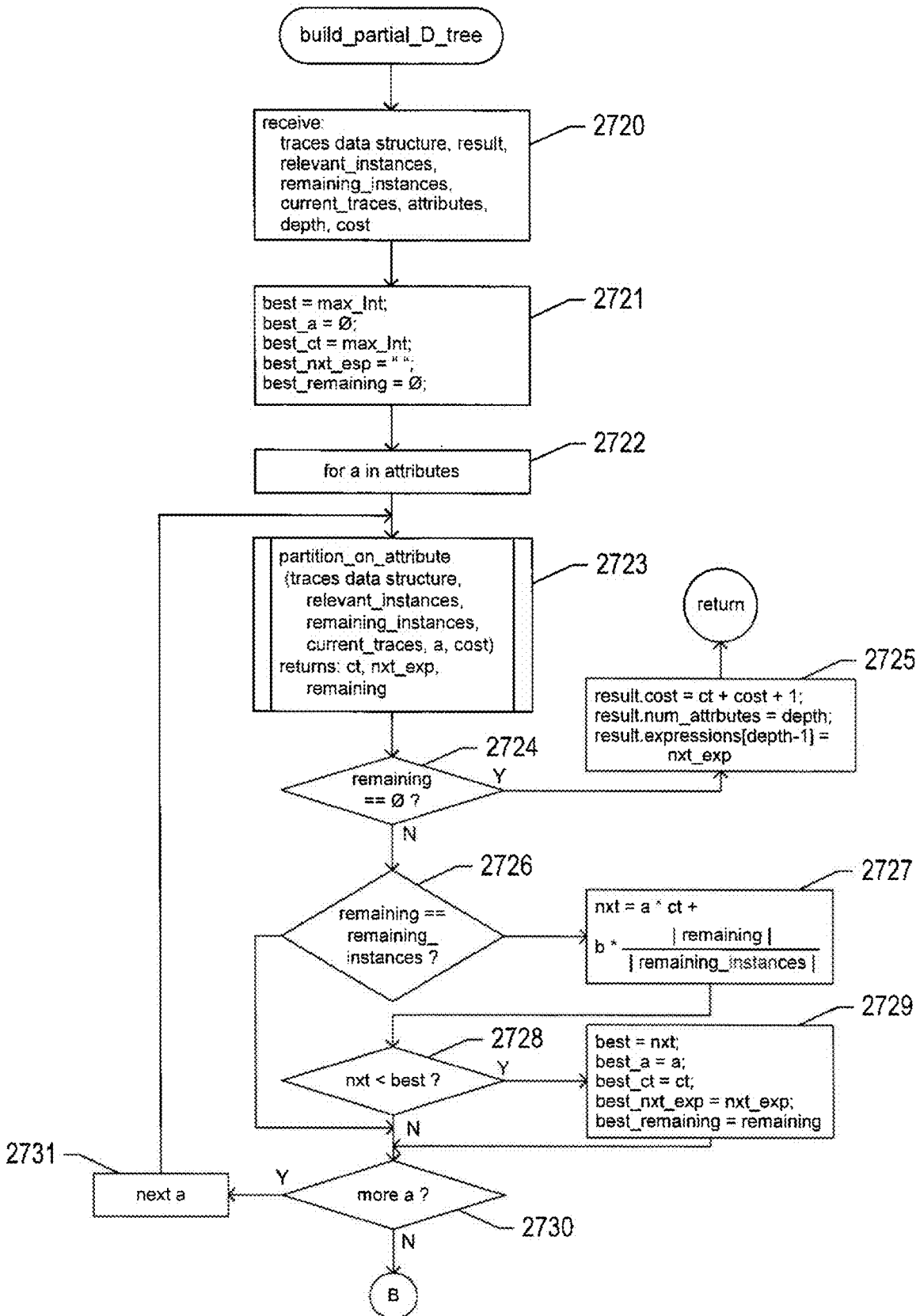

FIG. 27C

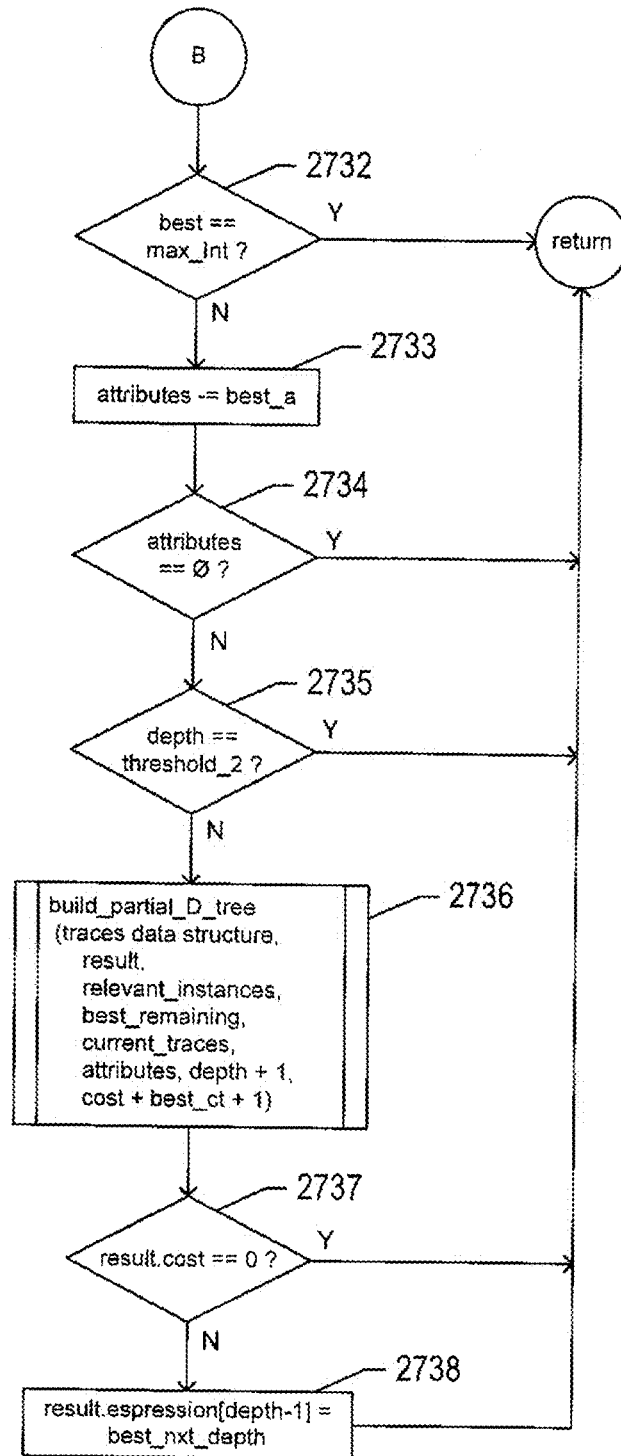

FIG. 27D

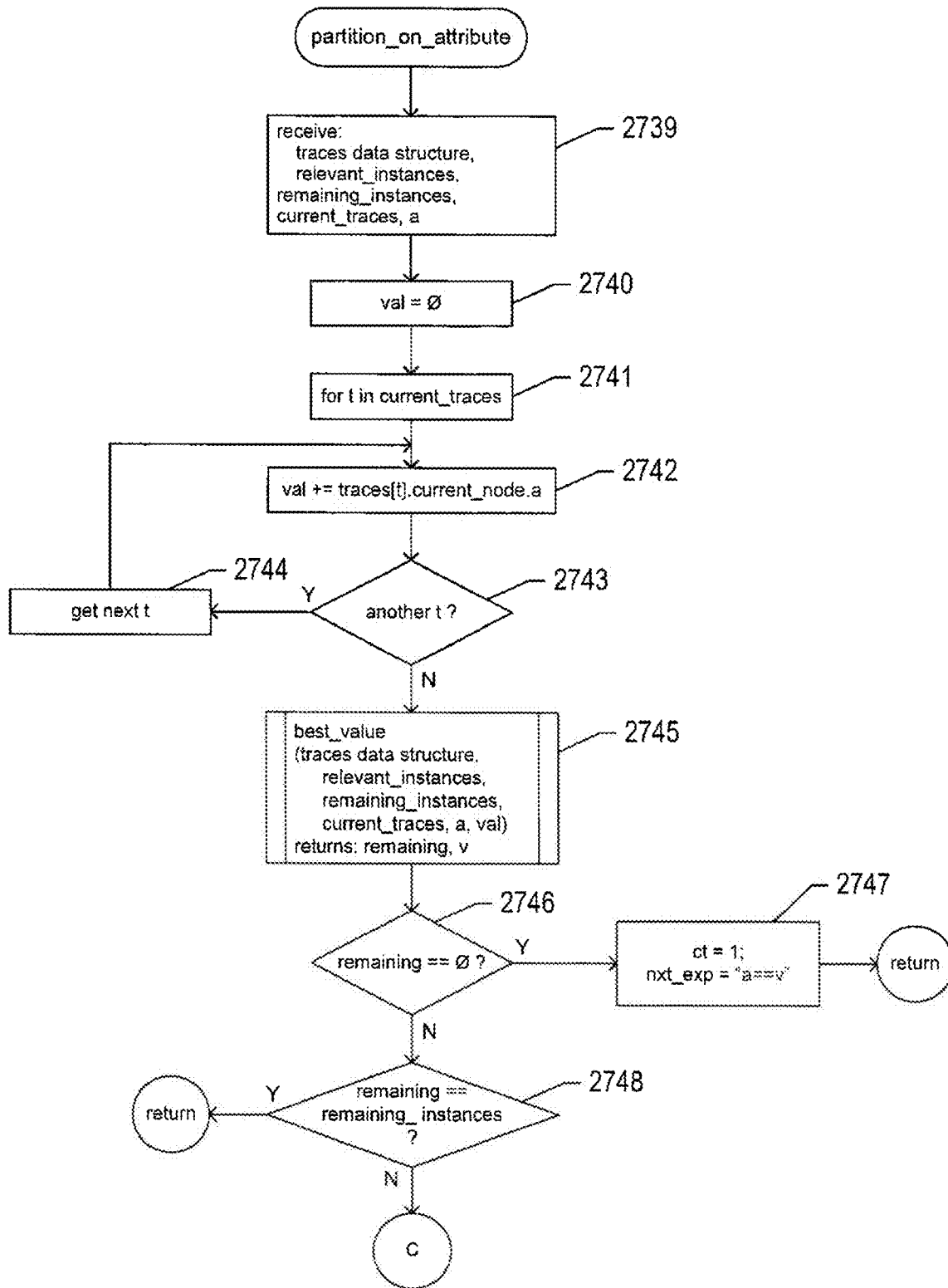

FIG. 27E



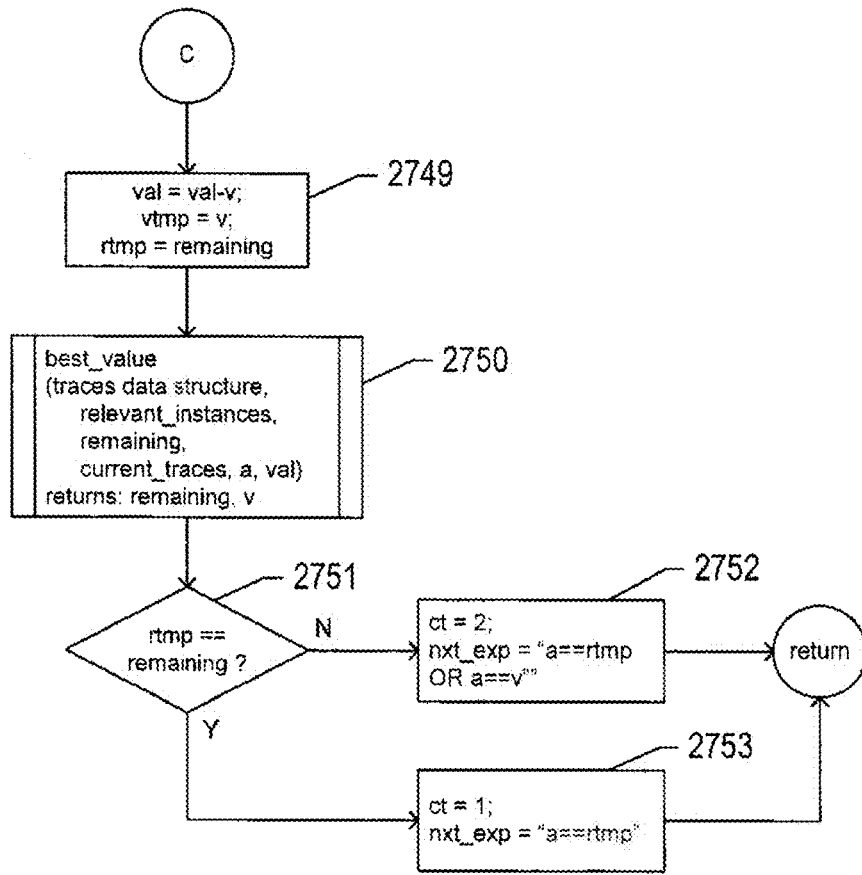

FIG. 27F

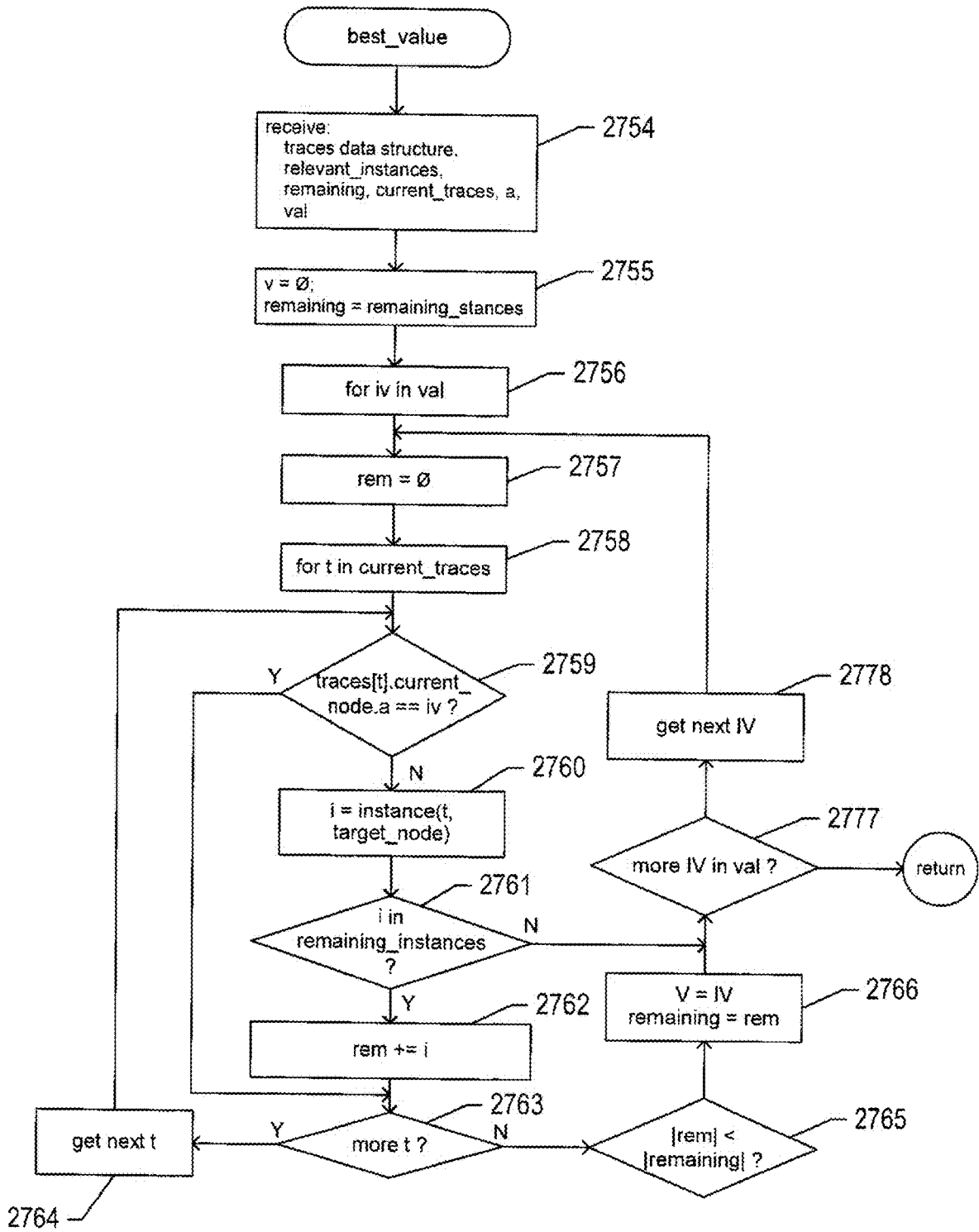

FIG. 27G

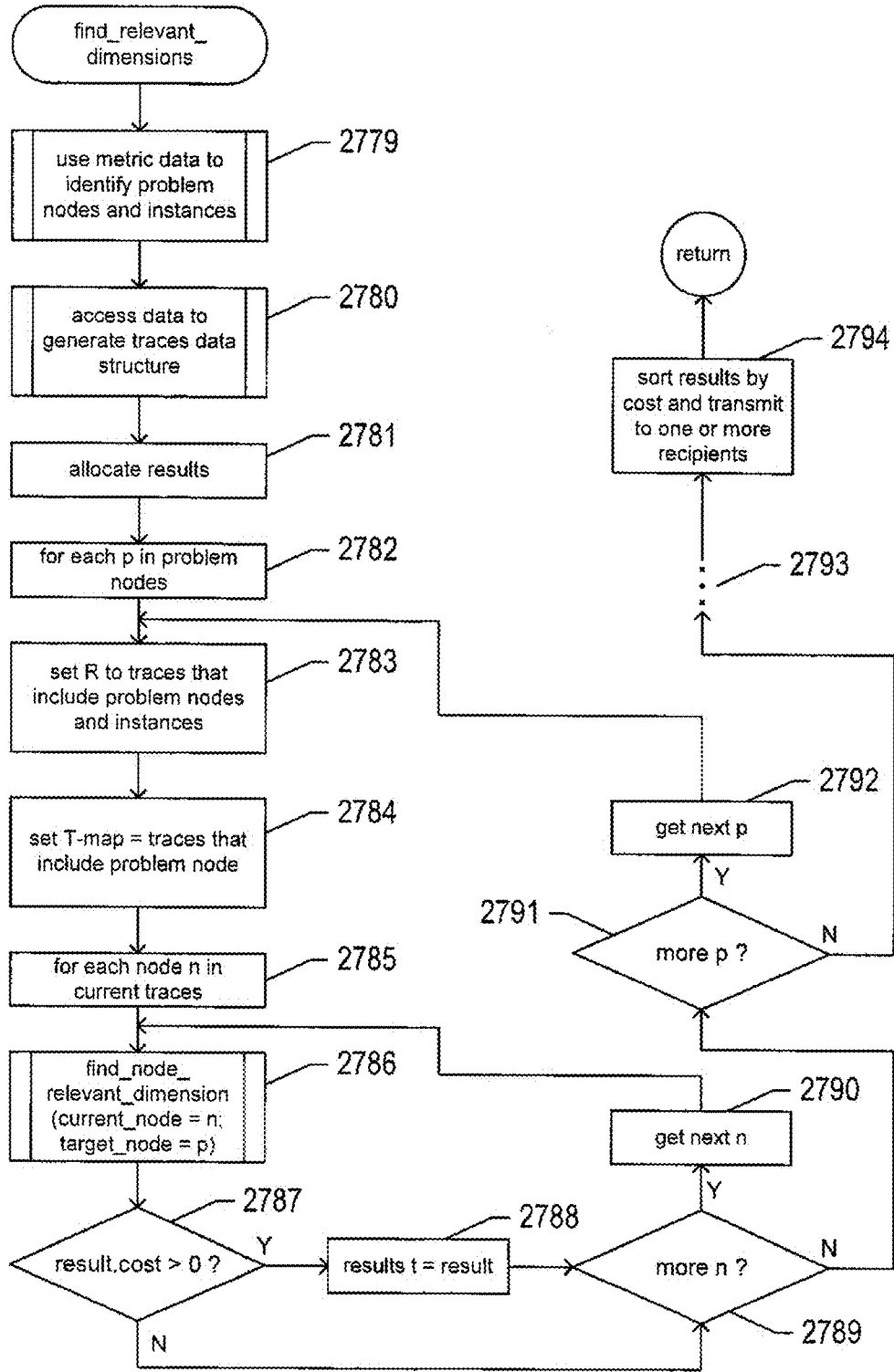

FIG. 27H

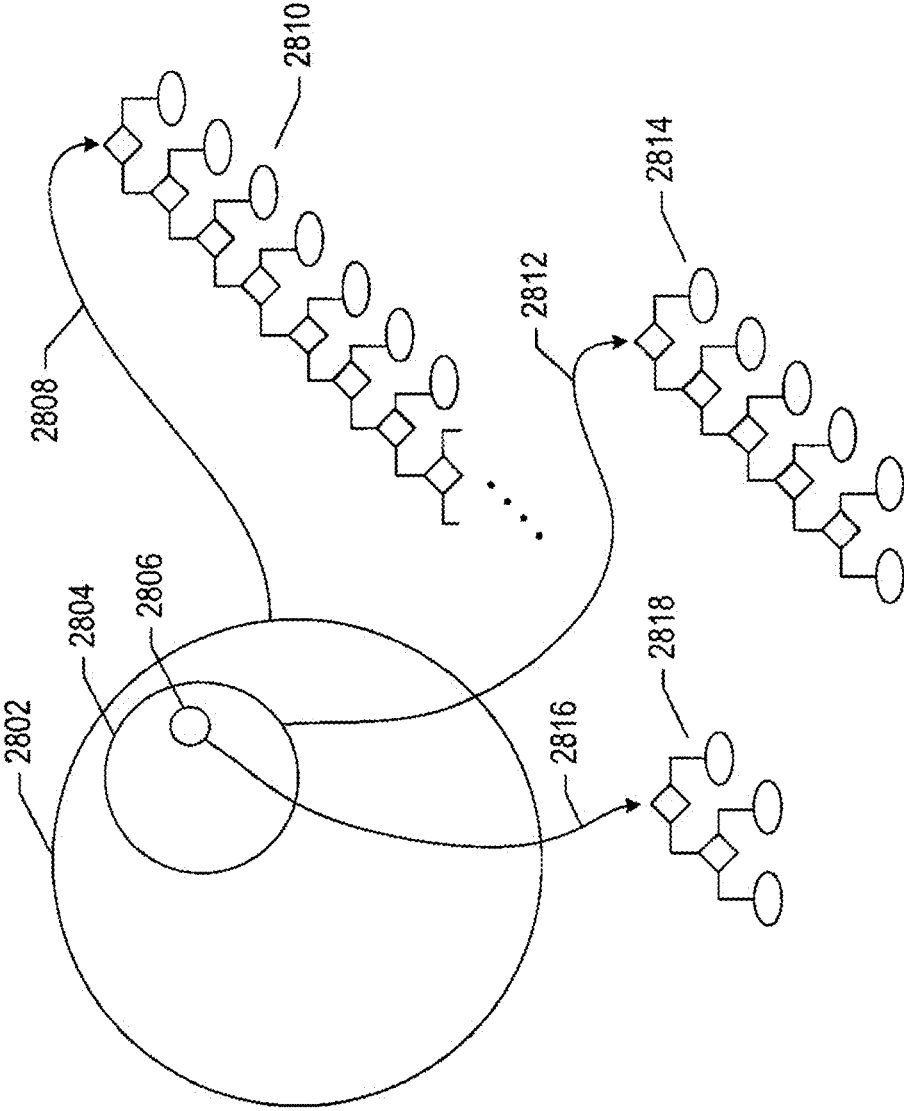

FIG. 28

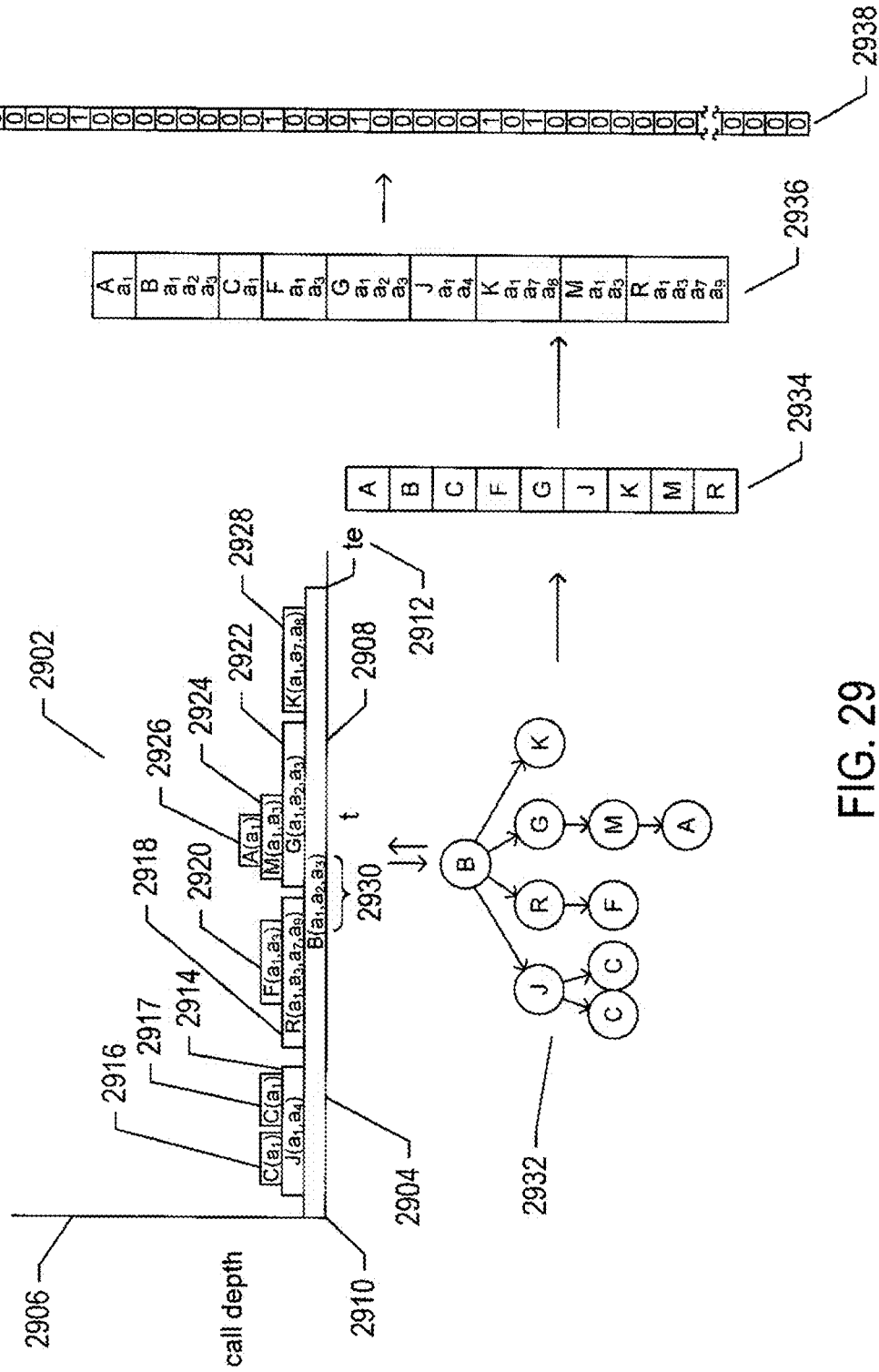

FIG. 29

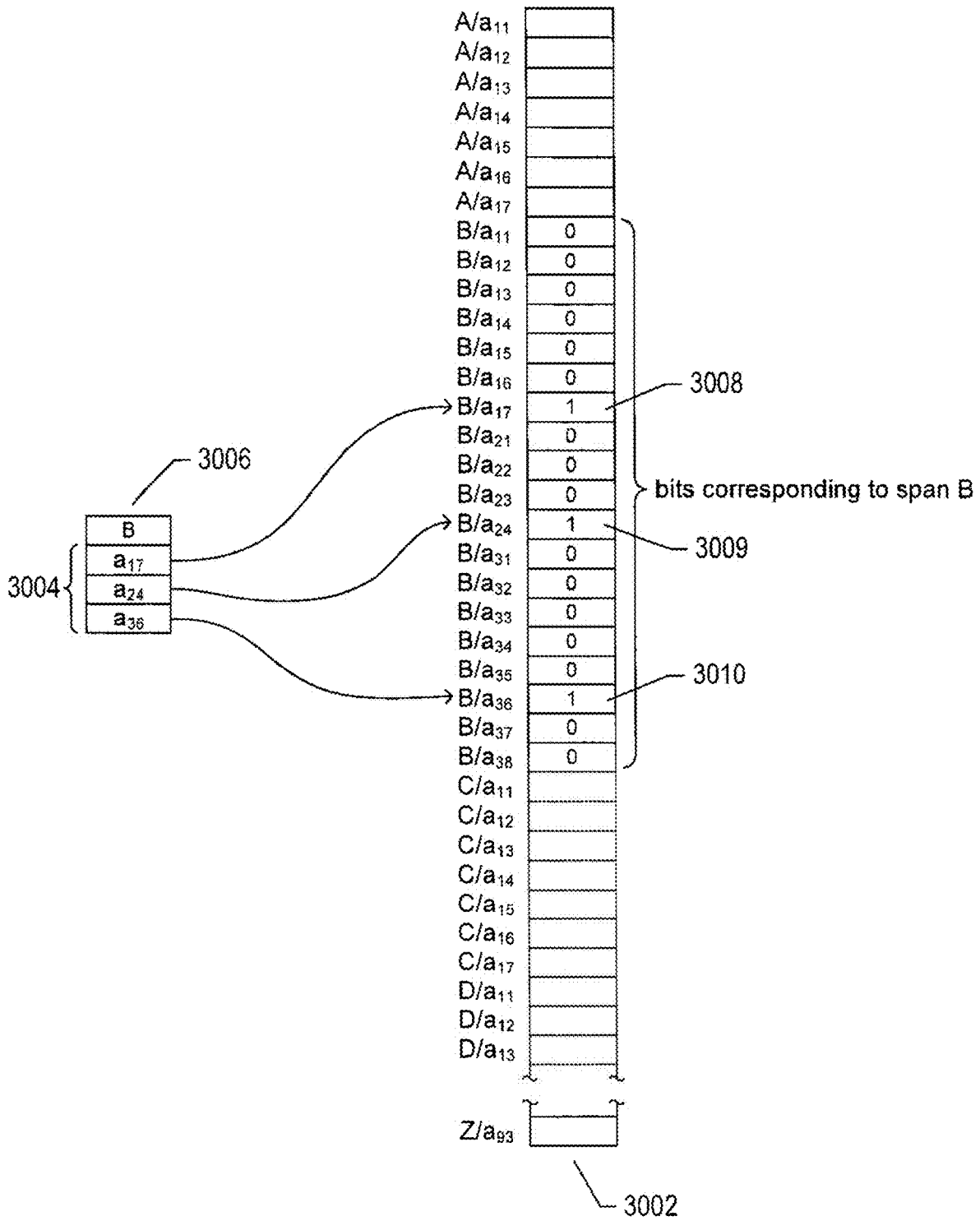

FIG. 30A

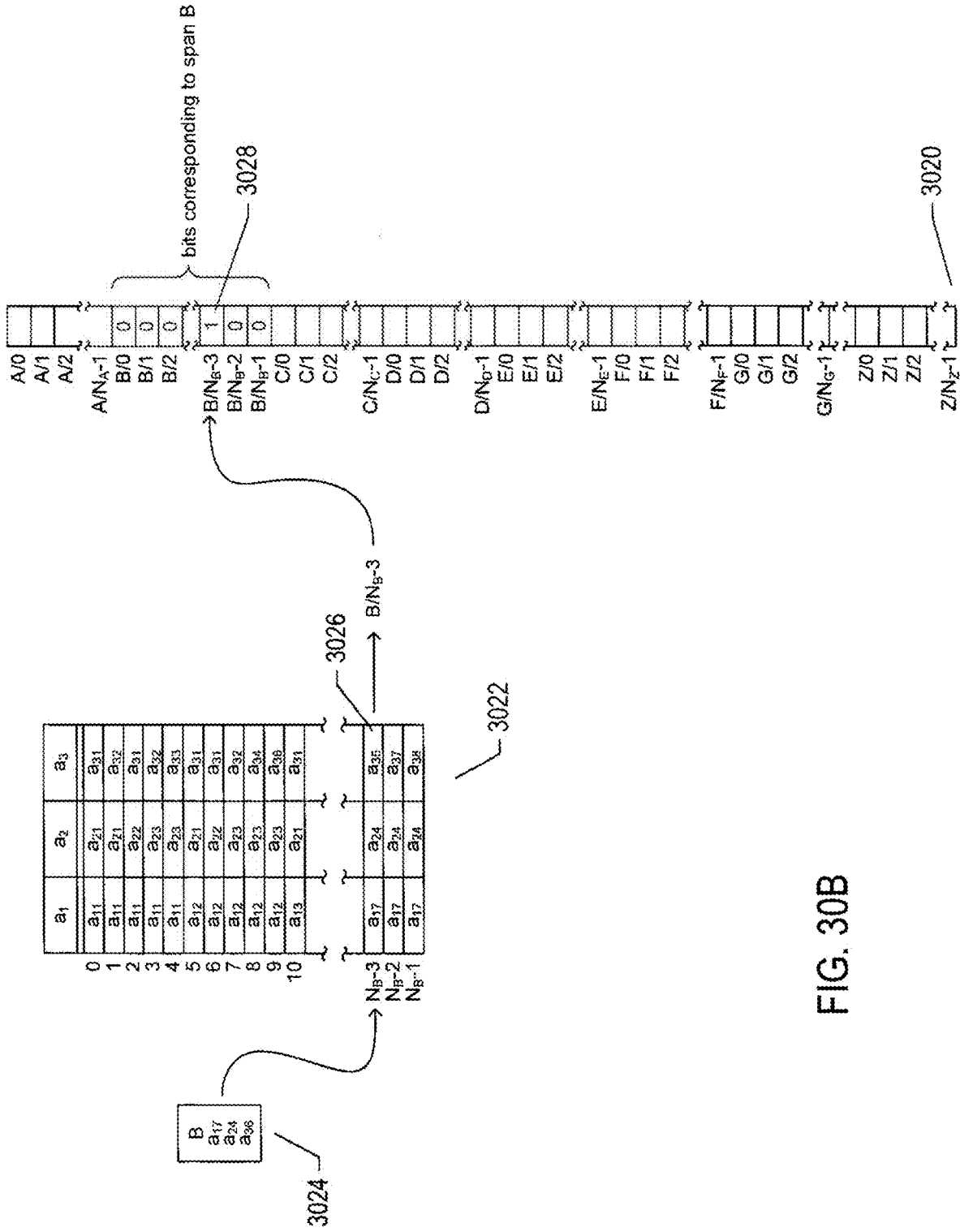

FIG. 30B

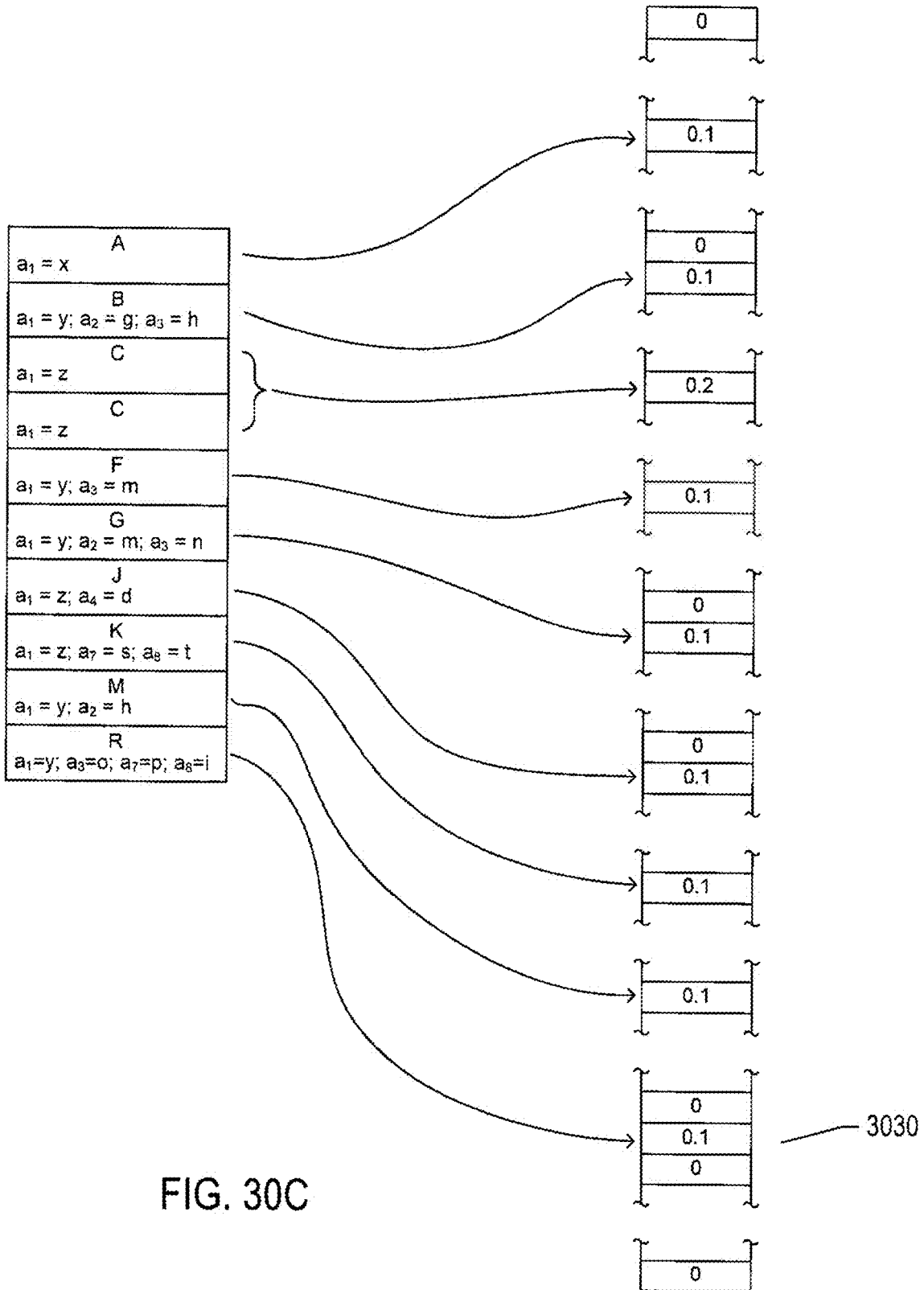

FIG. 30C



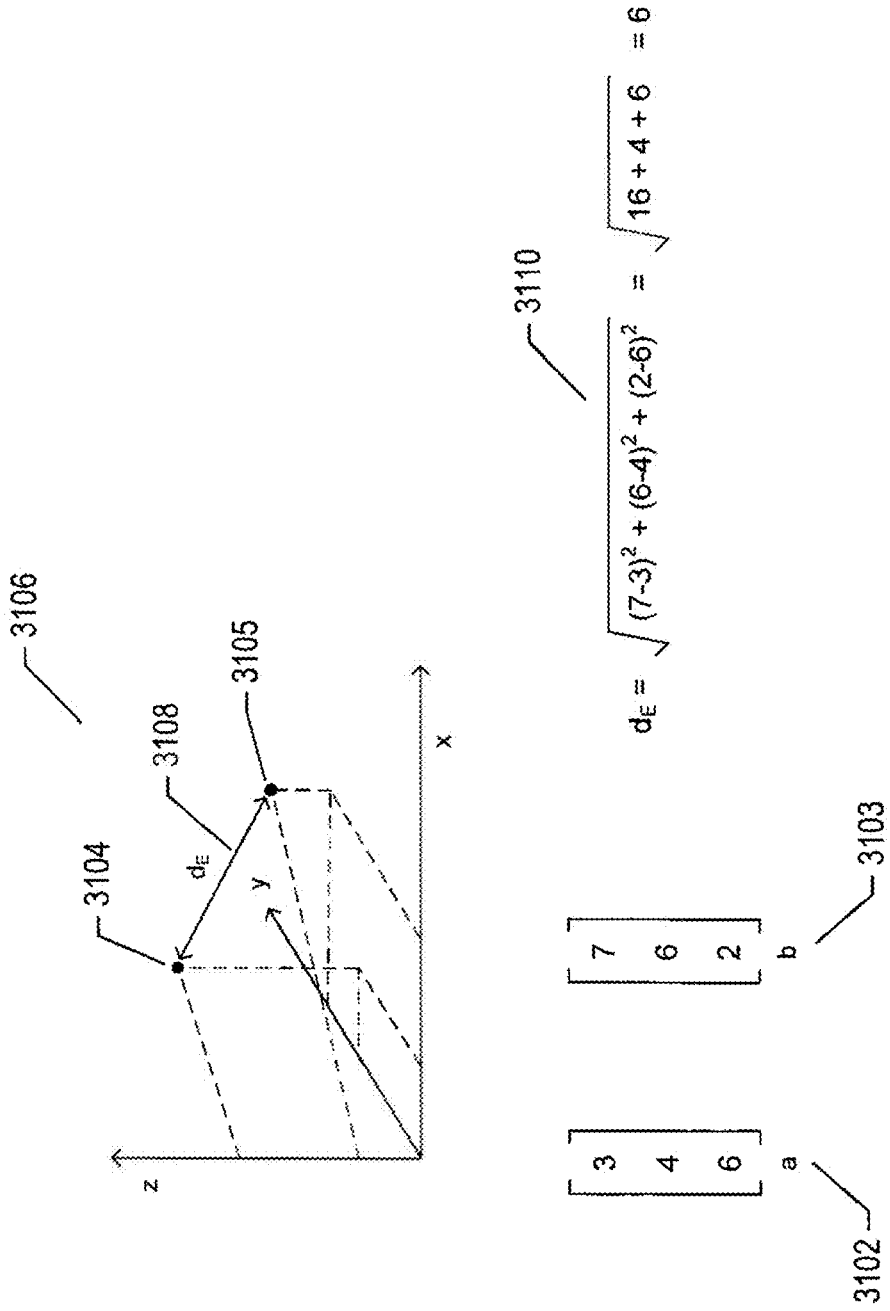

FIG. 31A

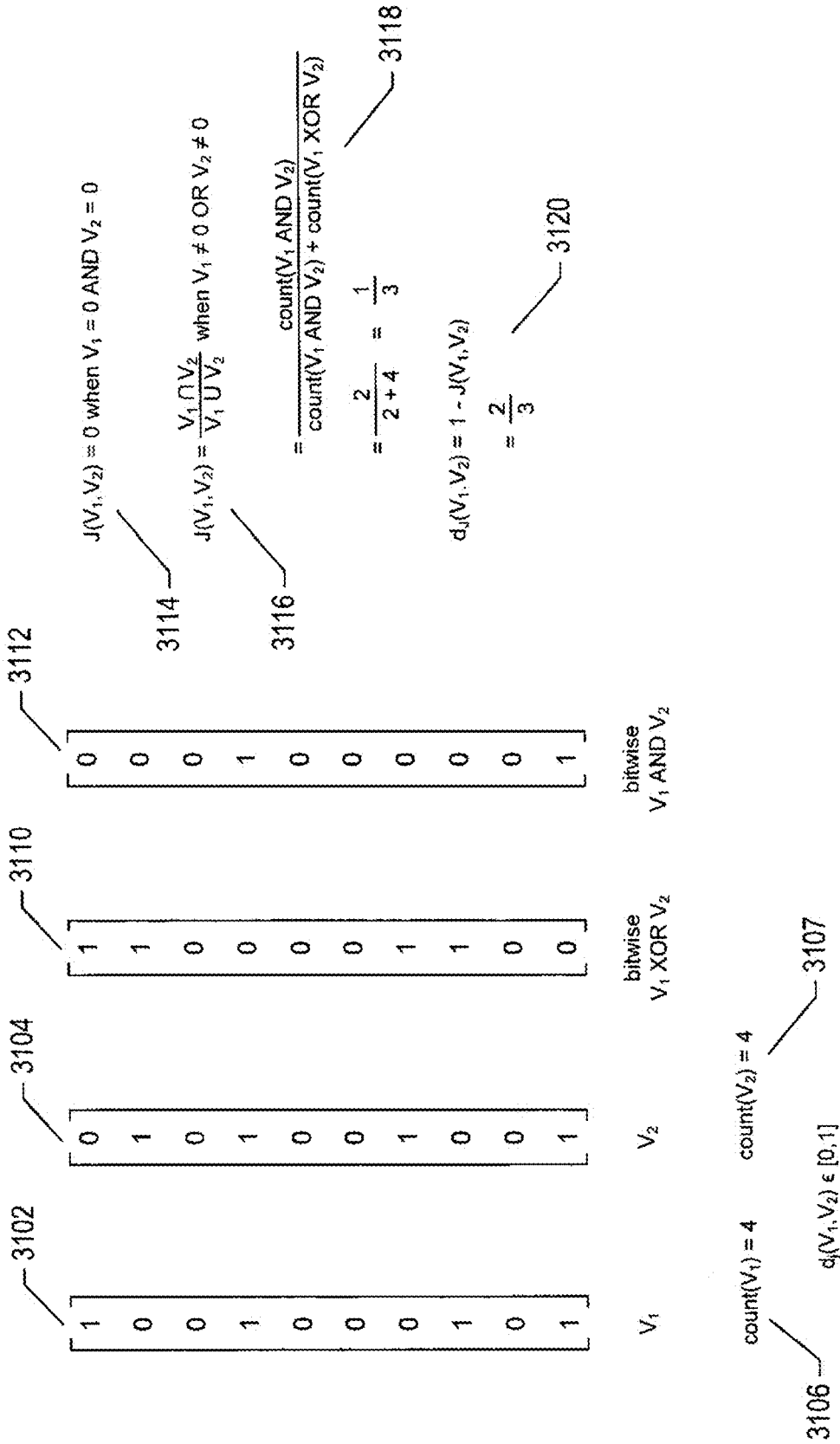

FIG. 31B

$$\begin{bmatrix} 1 & 0 & 0 & 1 & 0 & 0 & 0 & 1 & 0 & 1 \end{bmatrix}$$

$V_1$  3130

$$\begin{bmatrix} 0 & 1 & 0 & 1 & 0 & 0 & 1 & 0 & 0 & 1 \end{bmatrix}$$

$V_2$  3131

3132

$$d_{\cos} = \frac{V_1 \cdot V_2}{\|V_1\| \|V_2\|} = \frac{\sum_i (V_1)_i (V_2)_i}{\sqrt{\sum_i (V_1)_i^2} \cdot \sqrt{\sum_i (V_2)_i^2}}$$

$$= \frac{2}{2+2}$$

$$= \frac{1}{2}$$

FIG. 31C

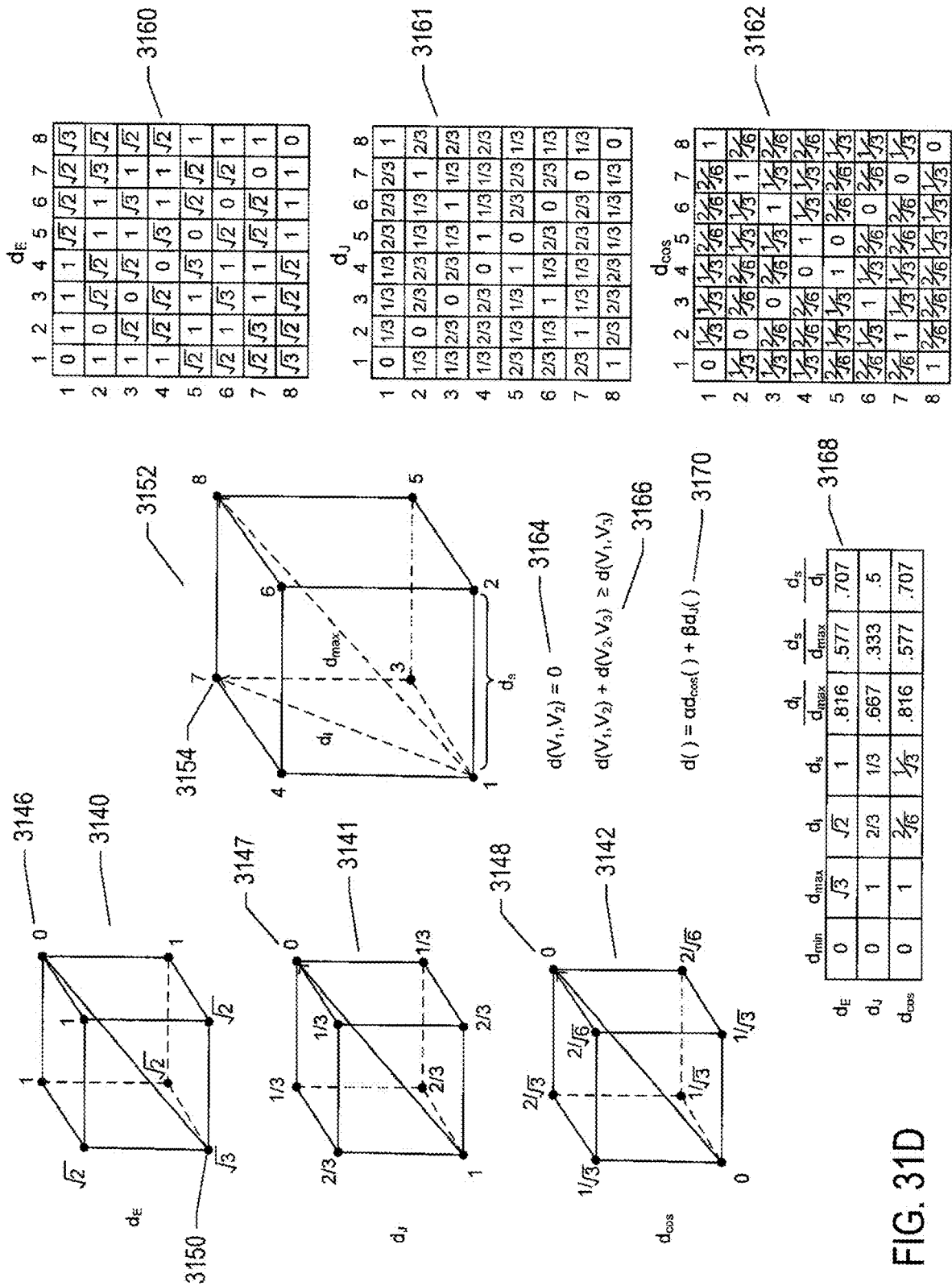

FIG. 31D

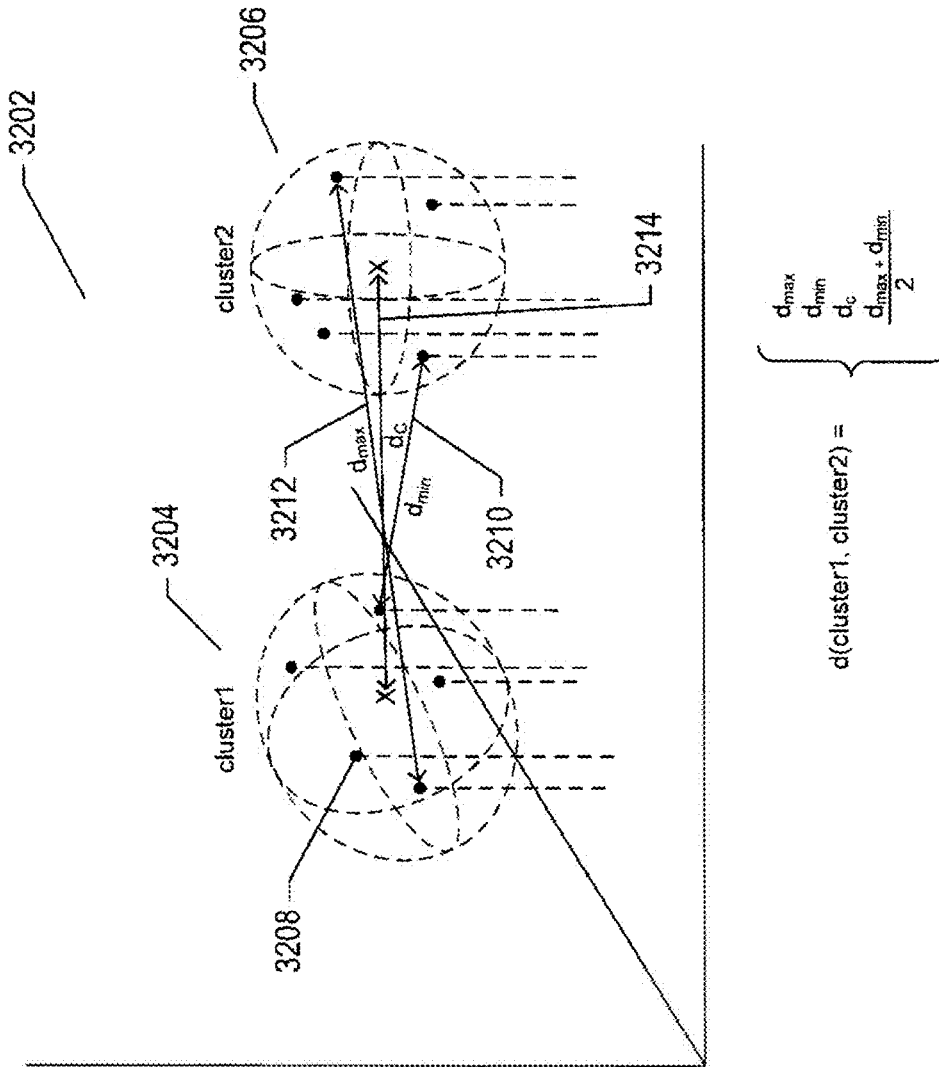

FIG. 32

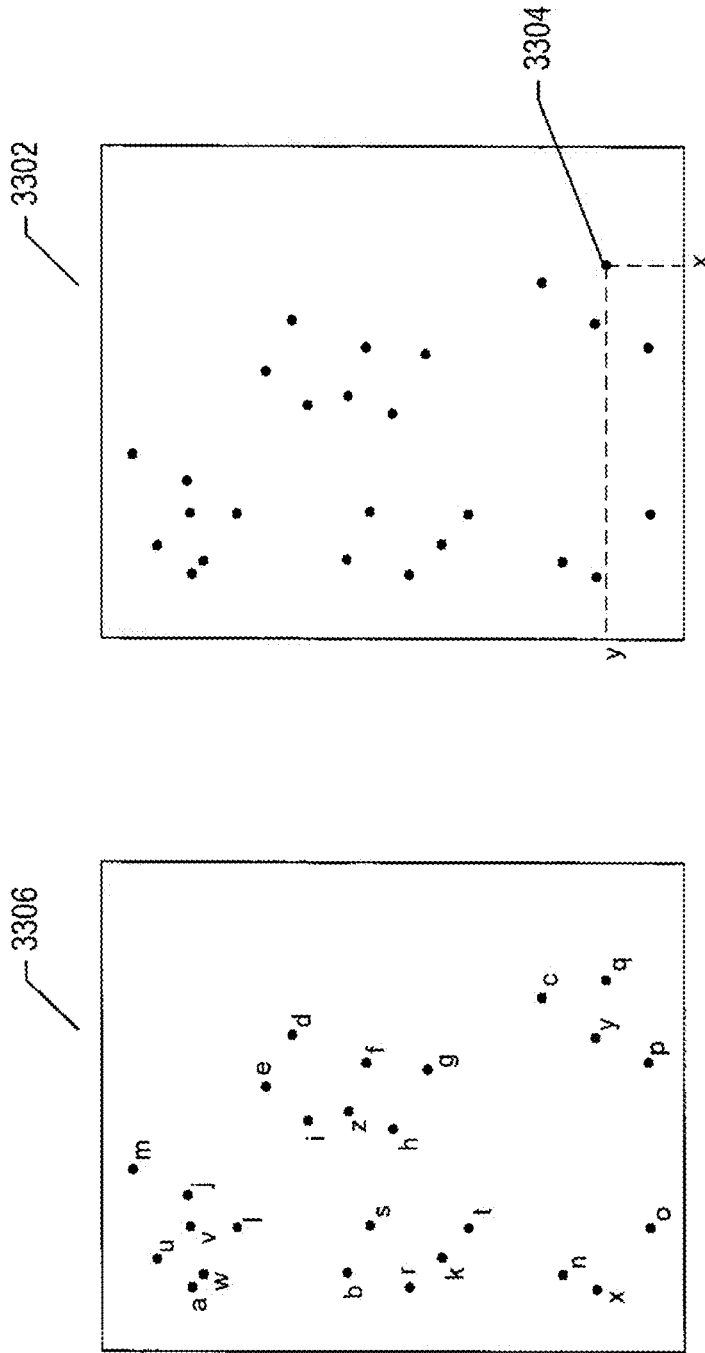

FIG. 33A

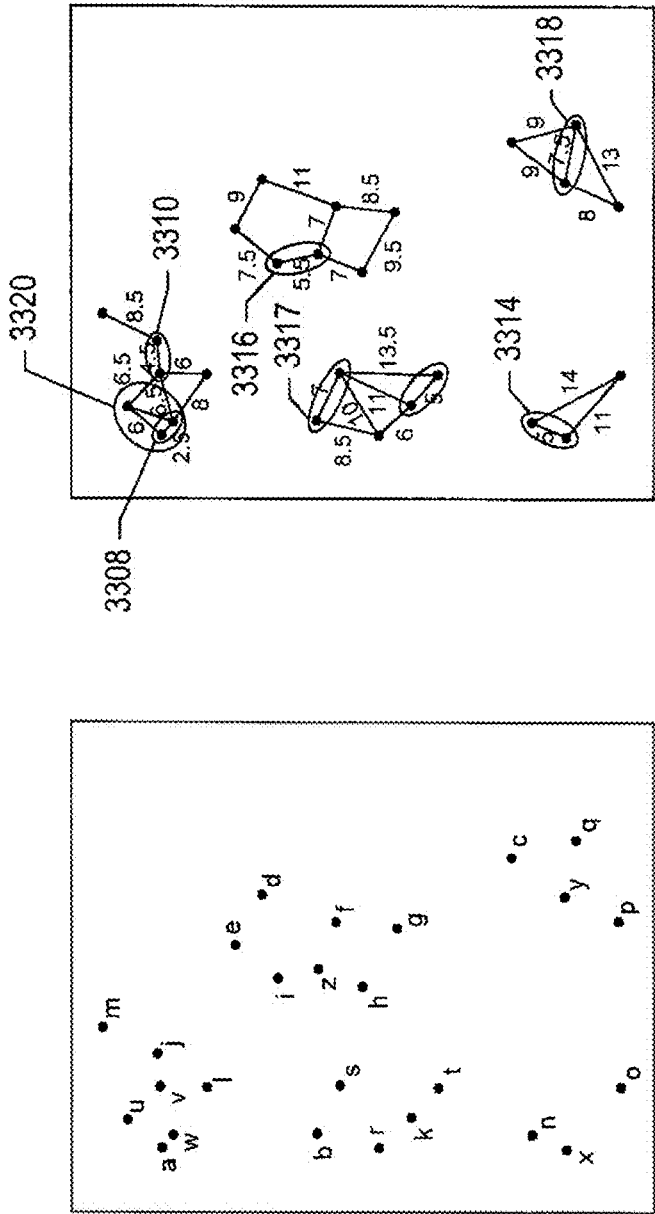

FIG. 33B

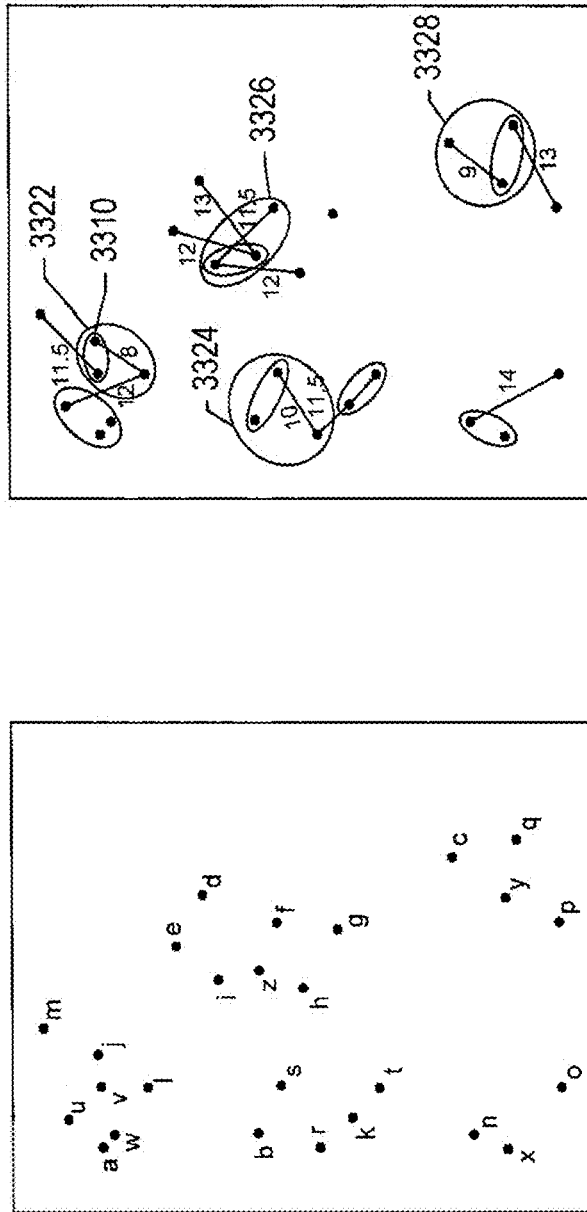

FIG. 33C



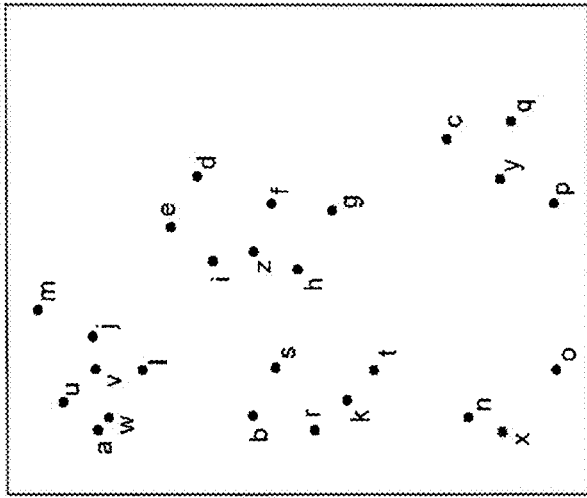
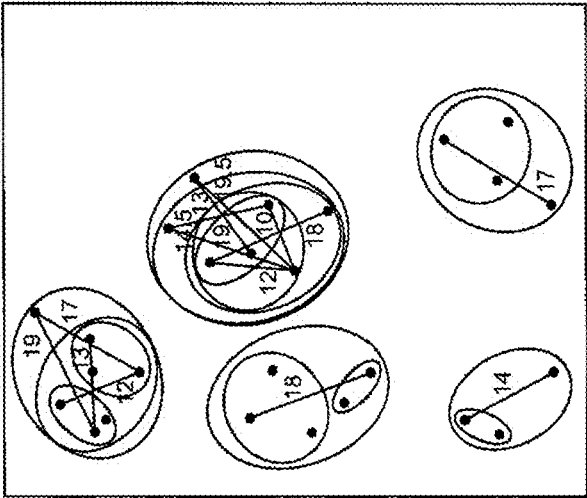

FIG. 33D

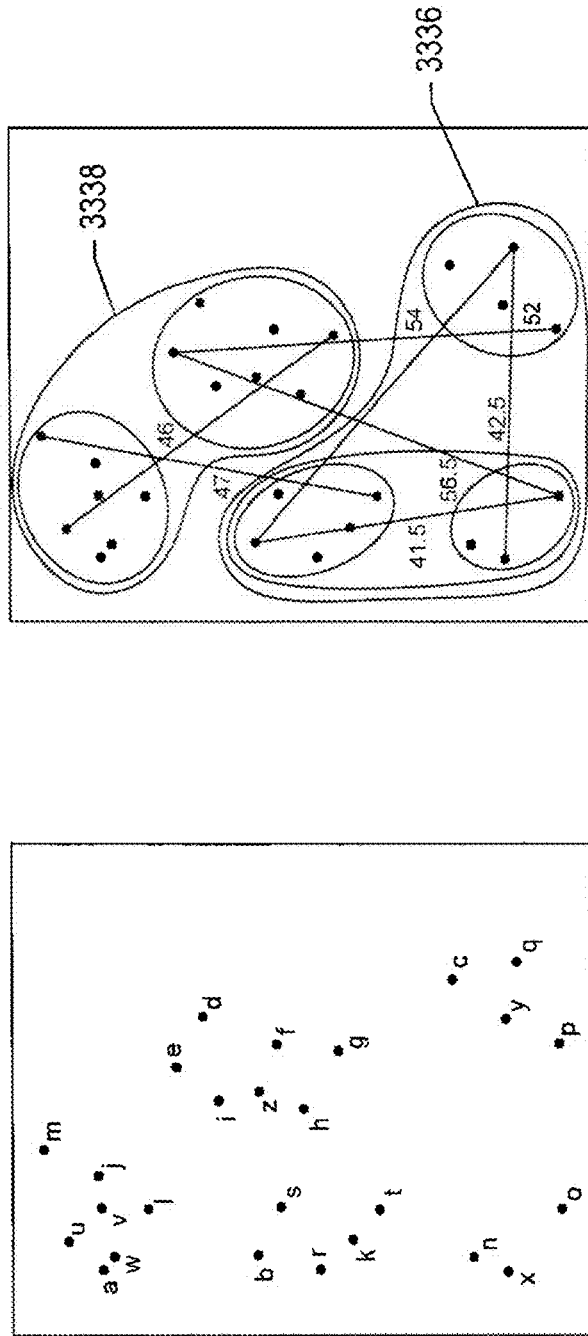

FIG. 33E

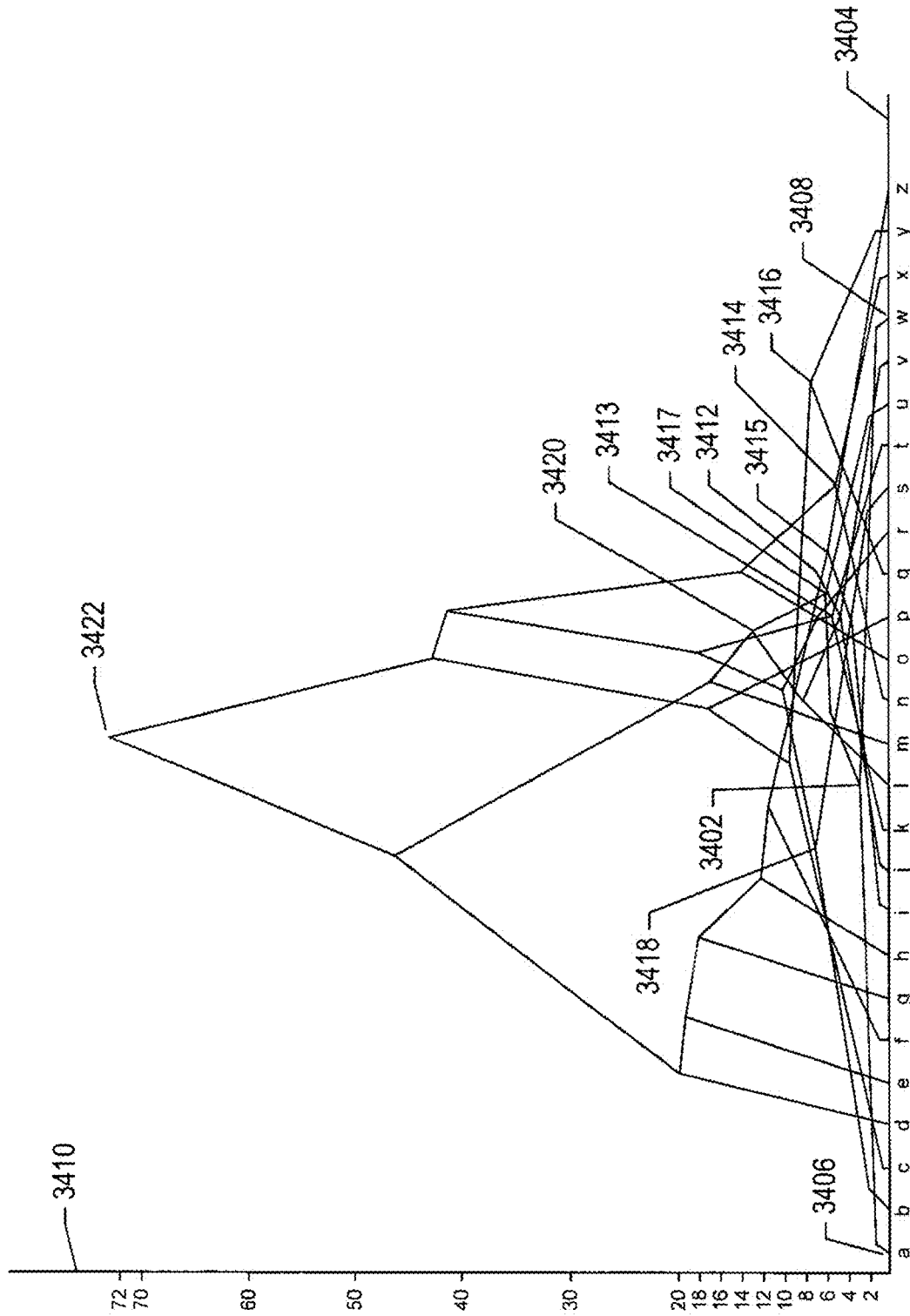

FIG. 34A

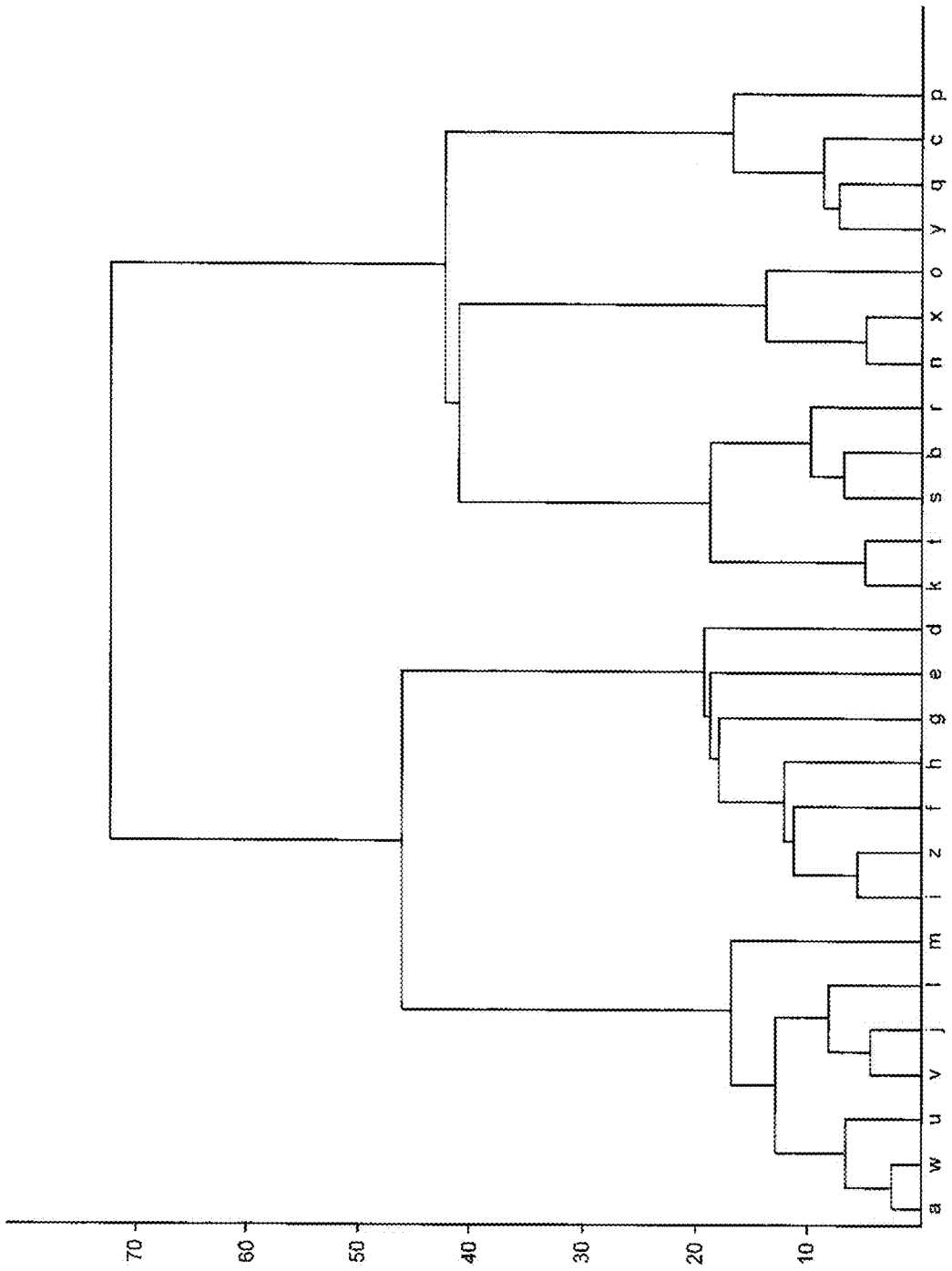

FIG. 34B

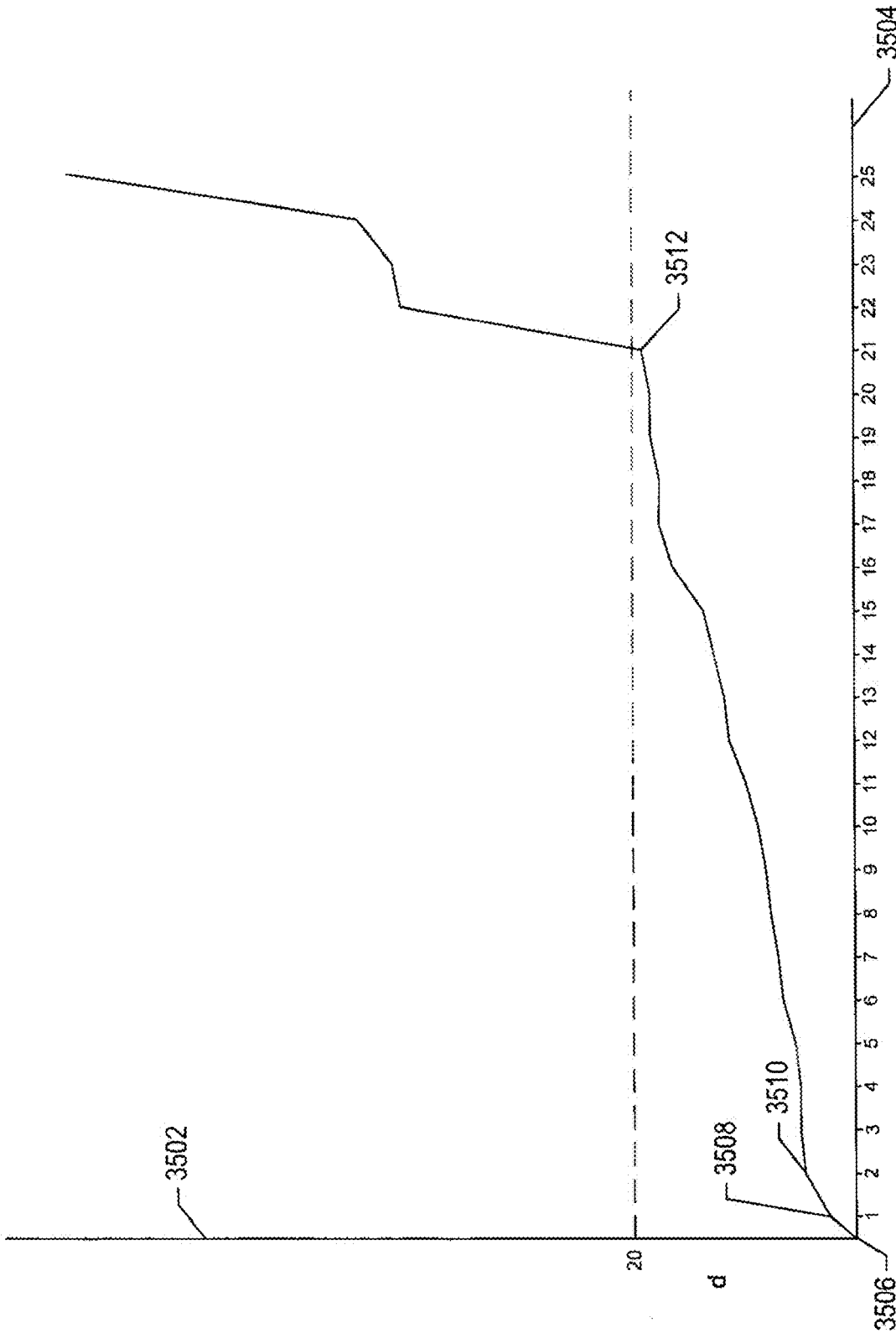

FIG. 35A

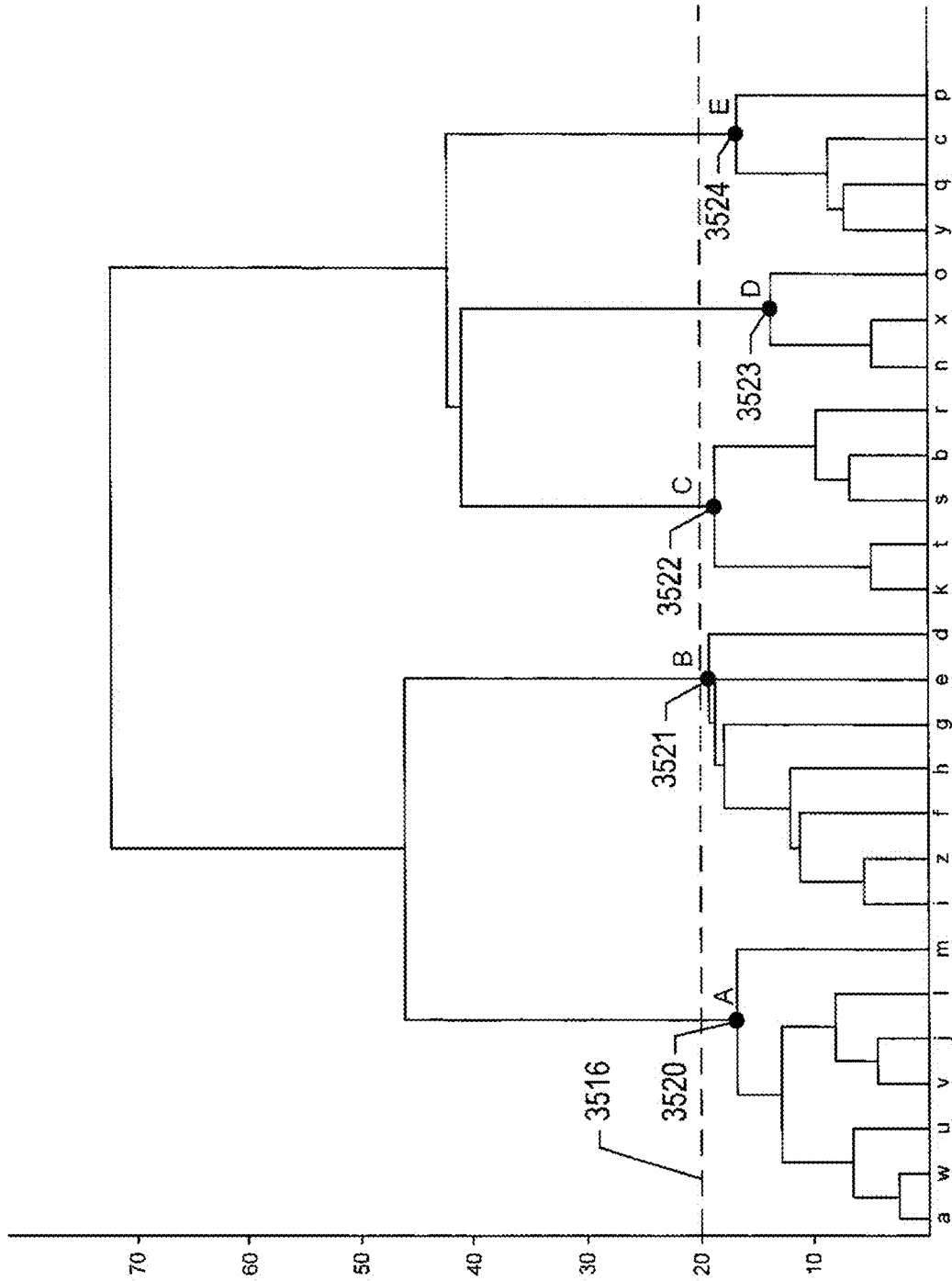

FIG. 35B

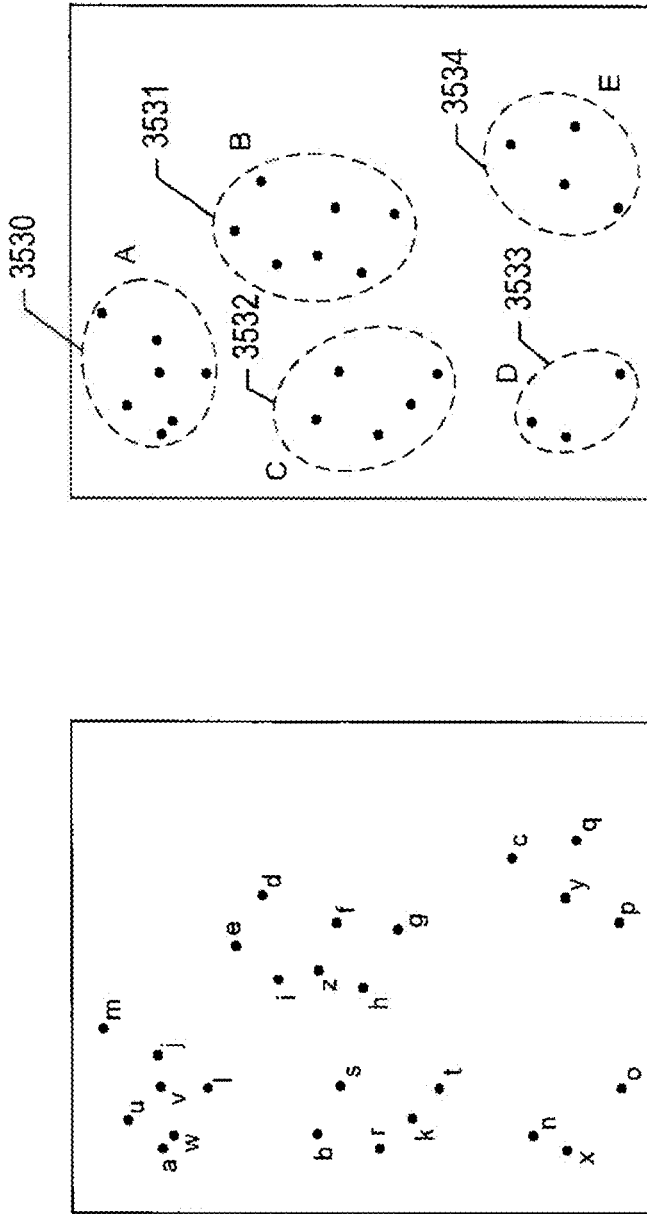

FIG. 35C

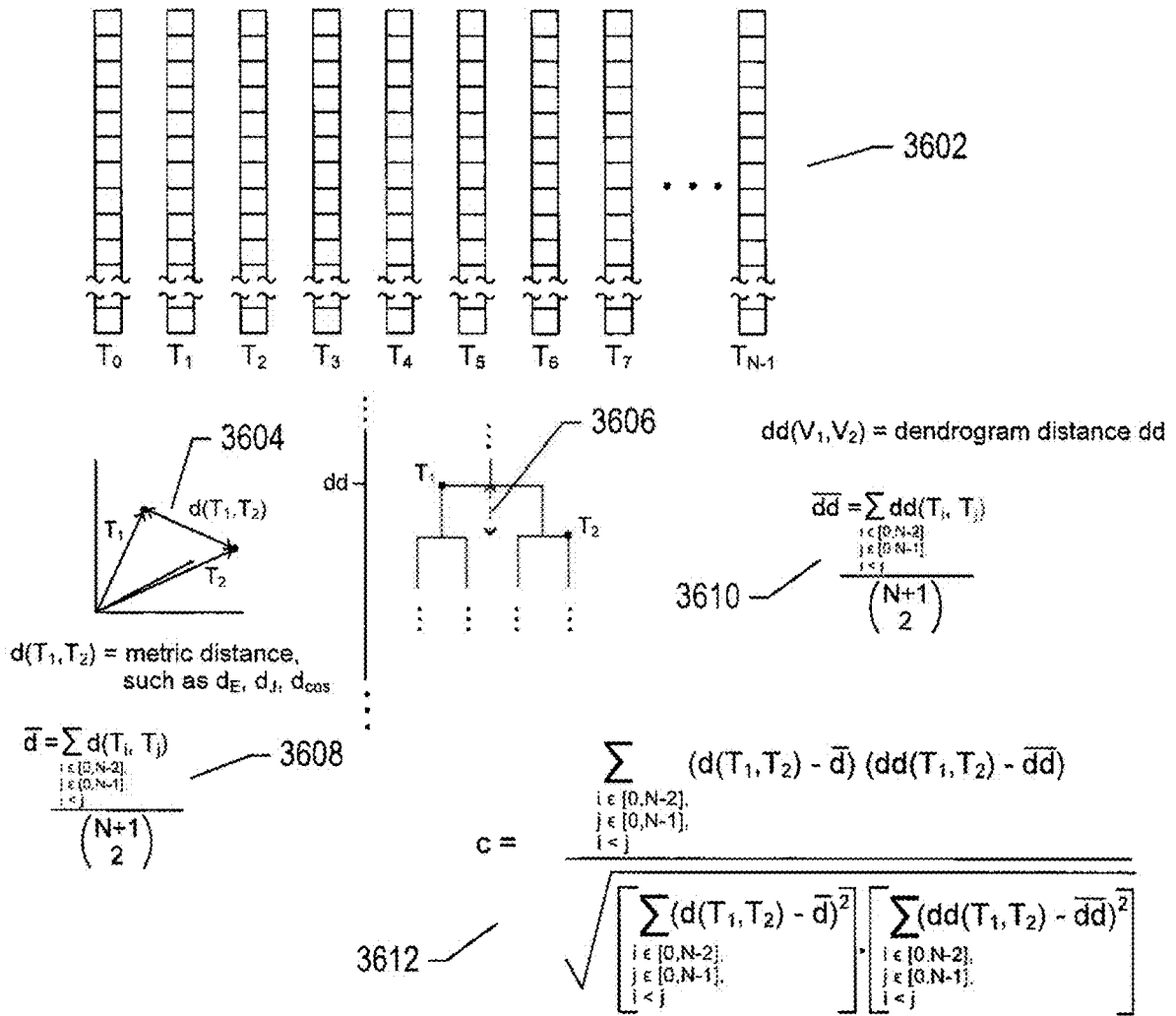

FIG. 36



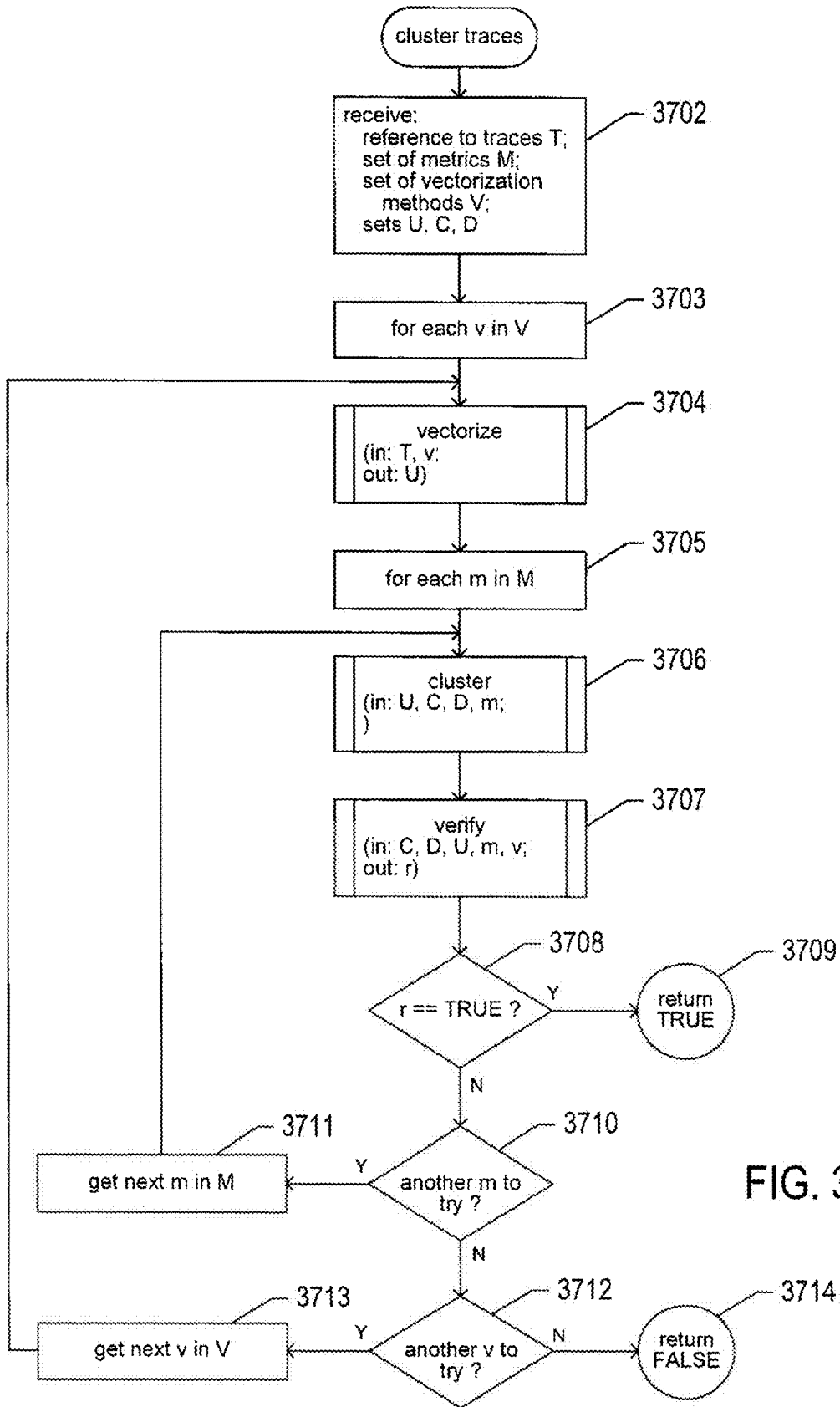

FIG. 37A

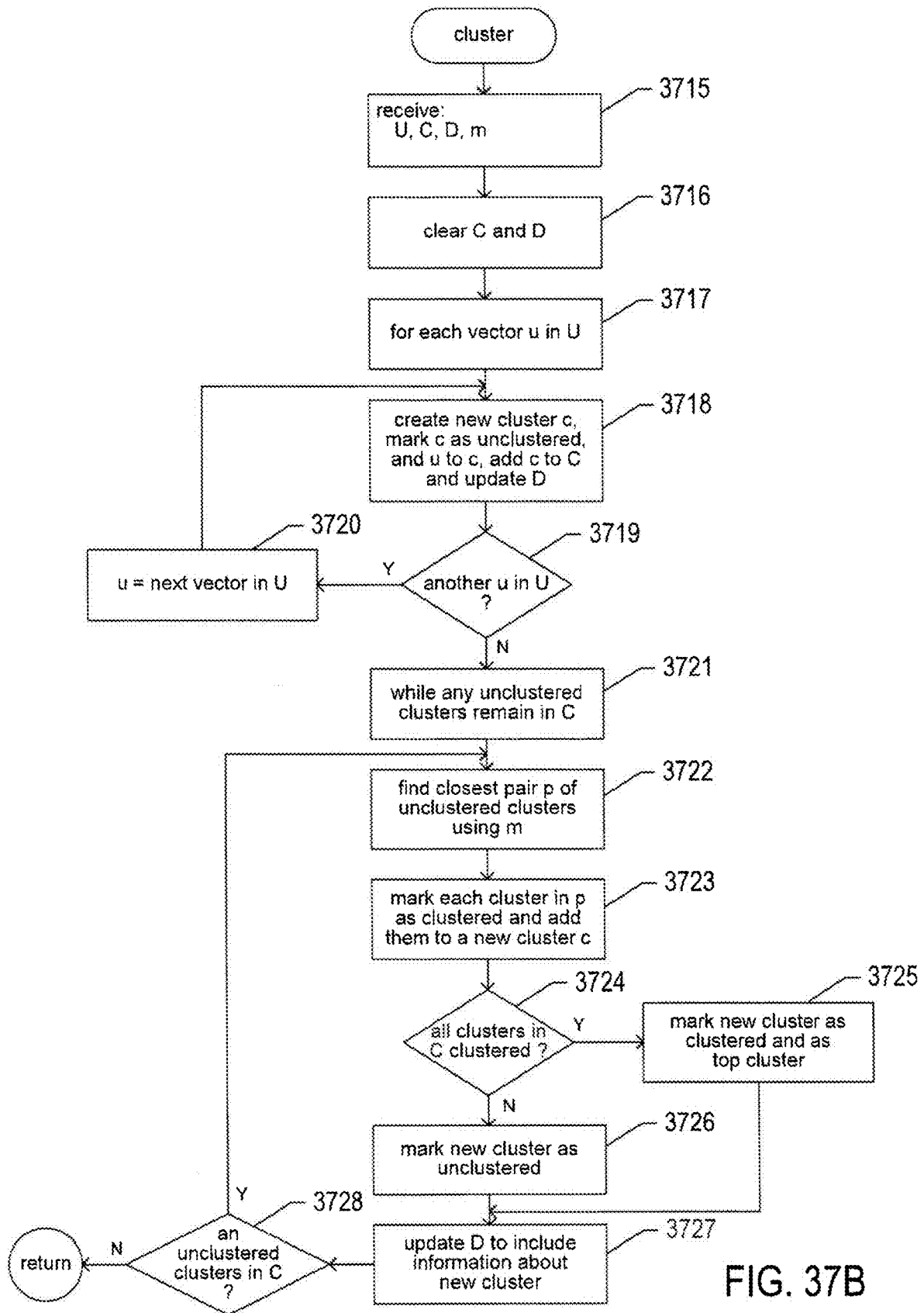

FIG. 37B

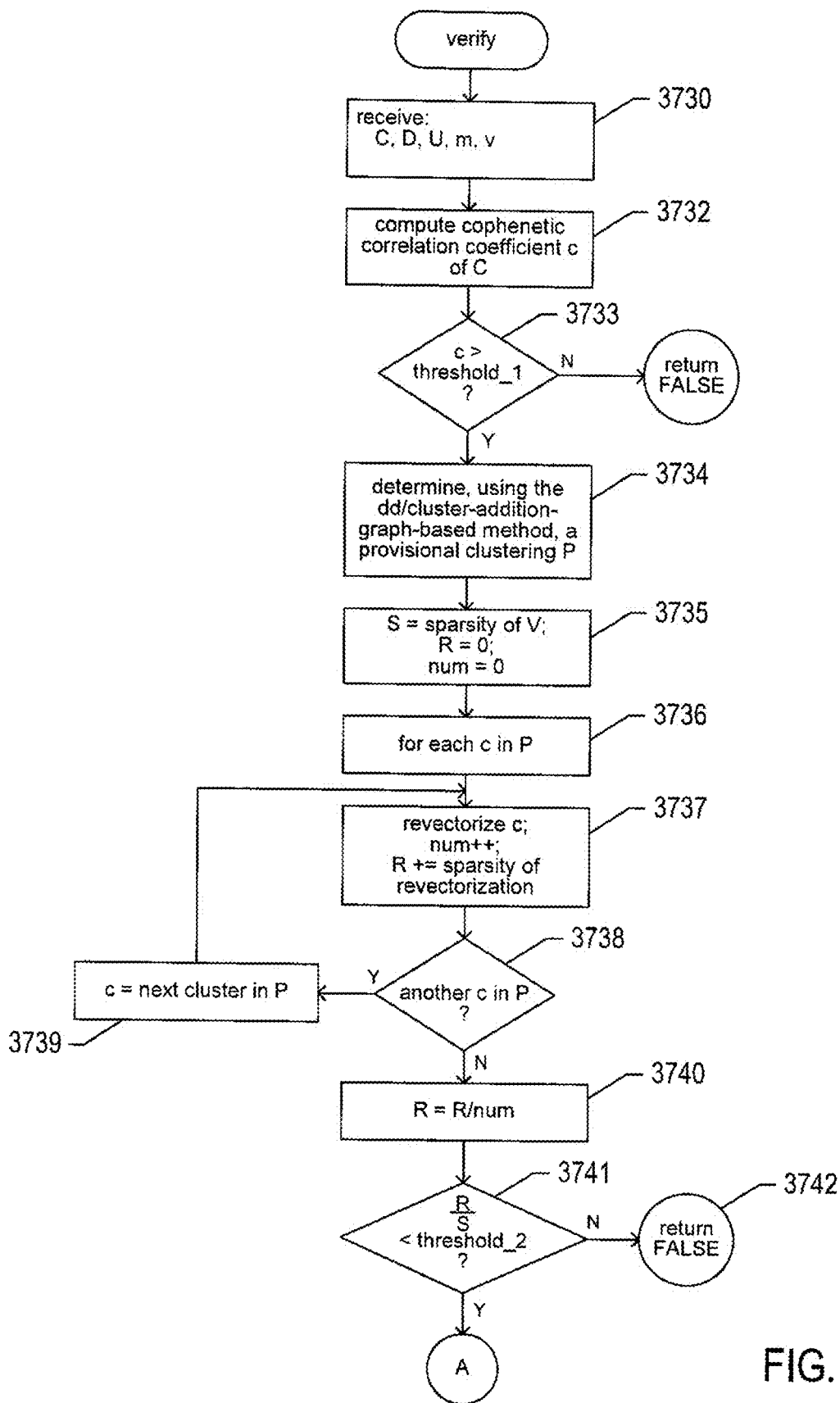

FIG. 37C

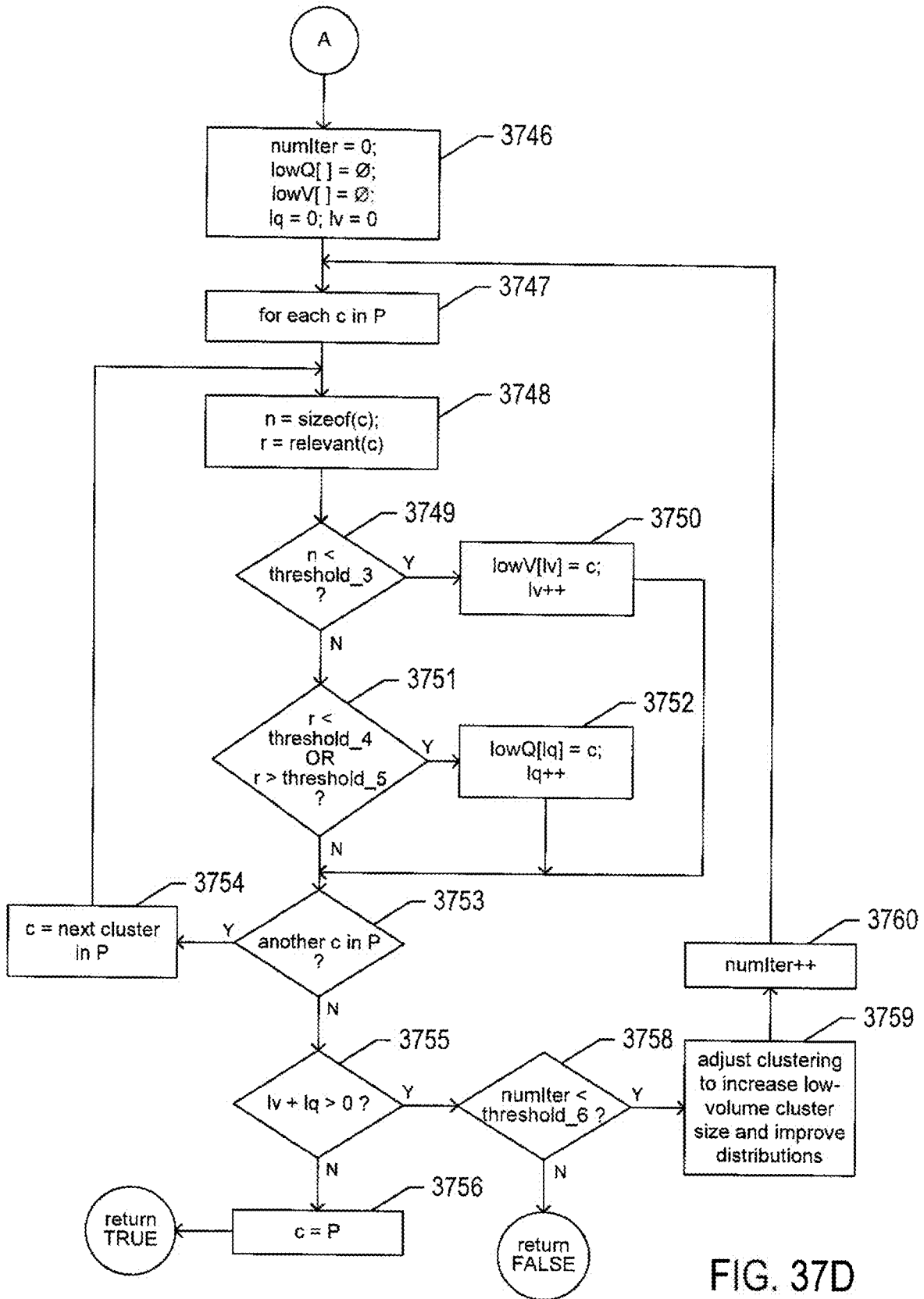

FIG. 37D

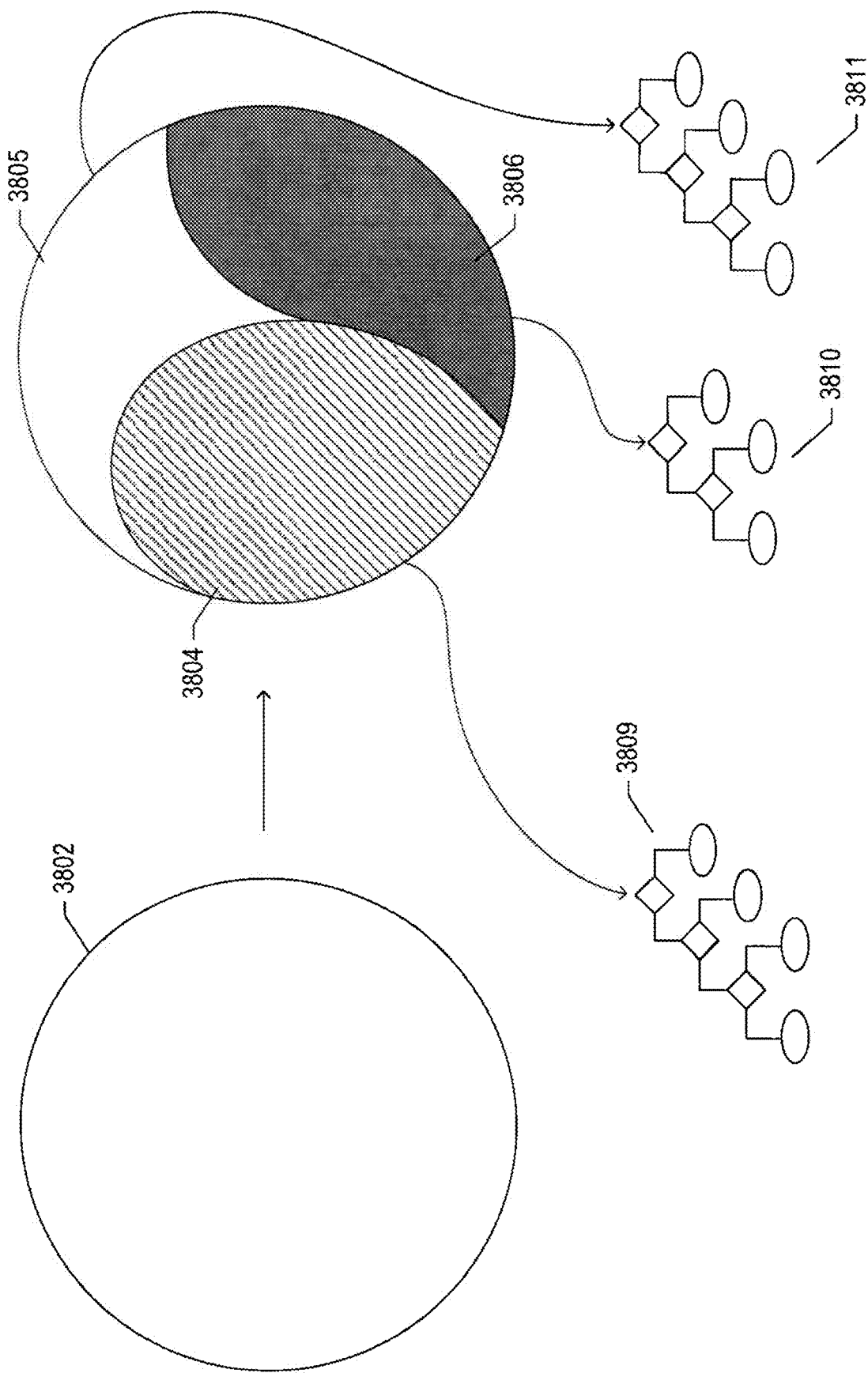

FIG. 38

**METHODS AND SYSTEMS THAT IDENTIFY DIMENSIONS RELATED TO ANOMALIES IN SYSTEM COMPONENTS OF DISTRIBUTED COMPUTER SYSTEMS USING CLUSTERED TRACES, METRICS, AND COMPONENT-ASSOCIATED ATTRIBUTE VALUES**

CROSS-REFERENCE TO RELATED APPLICATION

**[0001]** The application is a continuation-in-part of U.S. patent application Ser. No. 16/833,102, filed Mar. 27, 2020.

TECHNICAL FIELD

**[0002]** The current document is directed to distributed-computer-system and distributed-application administration and management and, in particular, to methods and systems that identify attribute dimensions relevant to anomalies detected in components of distributed applications and distributed computer systems.

BACKGROUND

**[0003]** During the past seven decades, electronic computing has evolved from primitive, vacuum-tube-based computer systems, initially developed during the 1940s, to modern electronic computing systems in which large numbers of multi-processor servers, work stations, and other individual computing systems are networked together with large-capacity data-storage devices and other electronic devices to produce geographically distributed computing systems with hundreds of thousands, millions, or more components that provide enormous computational bandwidths and data-storage capacities. These large, distributed computing systems are made possible by advances in computer networking, distributed operating systems and applications, data-storage appliances, computer hardware, and software technologies. However, despite all of these advances, the rapid increase in the size and complexity of computing systems has been accompanied by numerous scaling issues and technical challenges, including technical challenges associated with communications overheads encountered in parallelizing computational tasks among multiple processors, component failures, and distributed-system management. As new distributed-computing technologies are developed, and as general hardware and software technologies continue to advance, the current trend towards ever-larger and more complex distributed computing systems appears likely to continue well into the future.

**[0004]** As the complexity of distributed computing systems has increased, the management and administration of distributed computing systems has, in turn, become increasingly complex, involving greater computational overheads and significant inefficiencies and deficiencies. In fact, many desired management-and-administration functionalities are becoming sufficiently complex to render traditional approaches to the design and implementation of automated management and administration systems impractical, from a time and cost standpoint, and even from a feasibility standpoint. Therefore, designers and developers of various types of automated management-and-administration facilities related to distributed computing systems are seeking new approaches to implementing automated management-and-administration facilities and functionalities.

SUMMARY

**[0005]** The current document is directed to methods and systems that employ distributed-computer-system metrics collected by one or more distributed-computer-system metrics-collection services, call traces collected by one or more call-trace services, and attribute values for distributed-computer-system components to identify attribute dimensions related to anomalous behavior of distributed-computer-system components. In a described implementation, nodes correspond to particular types of system components and node instances are individual components of the component type corresponding to a node. Node instances are associated with attribute values and node are associated with attribute-value spaces defined by attribute dimensions. A set of call traces is partitioned, by clustering. Using attribute values and call traces, attribute dimensions that are likely related to particular anomalous behaviors of distributed-computer-system components are determined by decision-tree-related analyses for each partition and are reported to one or more computational entities to facilitate resolution of the anomalous behaviors.

BRIEF DESCRIPTION OF THE DRAWINGS

**[0006]** FIG. 1 provides a general architectural diagram for various types of computers.

**[0007]** FIG. 2 illustrates an Internet-connected distributed computing system.

**[0008]** FIG. 3 illustrates cloud computing.

**[0009]** FIG. 4 illustrates generalized hardware and software components of a general-purpose computer system, such as a general-purpose computer system having an architecture similar to that shown in FIG. 1.

**[0010]** FIGS. 5A-D illustrate two types of virtual machine and virtual-machine execution environments.

**[0011]** FIG. 6 illustrates an OVF package.

**[0012]** FIG. 7 illustrates virtual data centers provided as an abstraction of underlying physical-data-center hardware components.

**[0013]** FIG. 8 illustrates virtual-machine components of a VI-management-server and physical servers of a physical data center above which a virtual-data-center interface is provided by the VI-management-server.

**[0014]** FIG. 9 illustrates a cloud-director level of abstraction.

**[0015]** FIG. 10 illustrates virtual-cloud-connector nodes (“VCC nodes”) and a VCC server, components of a distributed system that provides multi-cloud aggregation and that includes a cloud-connector server and cloud-connector nodes that cooperate to provide services that are distributed across multiple clouds.

**[0016]** FIG. 11 illustrates a distributed service-oriented application.

**[0017]** FIGS. 12A-B illustrate a sequence of service calls that implement a particular distributed-service-oriented-application API call or endpoint.

**[0018]** FIGS. 13A-B illustrate service components and service nodes.

**[0019]** FIGS. 14A-C illustrate the scale of certain distributed-service-oriented-applications.

**[0020]** FIGS. 15A-B illustrate components of a call-tracing service.

[0021] FIGS. 16A-H illustrate and how the tracing service, discussed with reference to FIGS. 15A-B, collects a call trace.

[0022] FIG. 17 illustrates distributed-computing-system-component attributes and attribute values.

[0023] FIG. 18 illustrates a simple example of event-message logging and analysis.

[0024] FIG. 19 shows a small, 11-entry portion of a log file from a distributed computer system.

[0025] FIG. 20 illustrates one initial event-message-processing approach.

[0026] FIGS. 21A-B illustrate one of many different possible ways of storing attribute values for system components and metric values for system components generated from event messages or event records.

[0027] FIGS. 22A-B illustrates detection of the system-component operational anomalies using metric data.

[0028] FIGS. 23A-K illustrate one example of the currently disclosed methods for determining root causes of, and attributes that are likely to be relevant to, detected anomalies within distributed heating systems.

[0029] FIGS. 24A-B illustrate a second example of application of the currently disclosed methods for determining root causes of, and attributes that are likely to be relevant to, detected anomalies within distributed heating systems.

[0030] FIGS. 25A-D provide additional examples of identifying relevant dimensions with respect to problem-associated components within a distributed computing system.

[0031] FIGS. 26A-B illustrate data structures and analytical approaches used in the control-flow diagrams provided in FIGS. 27A-F to illustrate the decision-tree-based methods for identifying attribute dimensions relevant to observed anomalies in the operational behaviors of distributed-computer-system components.

[0032] FIGS. 27A-H provide control-flow diagrams that illustrate one implementation of the decision-tree-based analysis used by currently disclosed methods and systems for determining attribute dimensions of the distributed-computer-system components relevant to particular anomalous operational behaviors observed for one or more distributed-computer-system components.

[0033] FIG. 28 illustrates a problem with applying dimensional analysis to very large sets of call traces.

[0034] FIG. 29 illustrates one approach to vectorizing call traces.

[0035] FIGS. 30A-C illustrate several approaches to generating a final vector from the expanded-elements vector 2936 shown in FIG. 29.

[0036] FIGS. 31A-D illustrates several different types of metrics that can be used to determine the distance between two vectors.

[0037] FIG. 32 illustrates various different distance metrics for clusters.

[0038] FIGS. 33A-E illustrate one approach to clustering vectors within the class of clustering methods referred to as “agglomerative” or “bottom-up.”

[0039] FIGS. 34A-B show two versions of a dendrogram generated during the vector clustering illustrated in FIGS. 33A-E.

[0040] FIGS. 35A-C illustrates cluster selection.

[0041] FIG. 36 illustrates the cophenetic correlation.

[0042] FIGS. 37A-D provide control-flow diagrams for a routine “trace types,” and additional routines called by the routine “trace types,” that together partition a set of call

traces into a number of subsets of related traces, each subset representing a different trace type.

[0043] FIG. 38 summarizes the currently disclosed clustering method for partitioning a set of call traces into subsets for dimensional analysis.

#### DETAILED DESCRIPTION

[0044] The current document is directed to methods and systems that automatically identify attribute dimensions of component nodes that are likely related to the causes of component-operation anomalies. In a first subsection, below, a detailed description of computer hardware, complex computational systems, and virtualization is provided with reference to FIGS. 1-10. In a second subsection, distributed service-oriented applications, node attributes, call traces, and metric data are discussed, with reference to FIGS. 11-22B. A third subsection discloses the dimensional-analysis methods and systems to which the current document is directed, with reference to FIGS. 23A-27H. A fourth subsection discloses call-trace-clustering methods and systems to which the current document is directed, with reference to FIGS. 23A-27H.

[0045] Computer Hardware, Complex, Computational Systems, and Virtualization

[0046] The term “abstraction” is not, in any way, intended to mean or suggest an abstract idea or concept. Computational abstractions are tangible, physical interfaces that are implemented, ultimately, using physical computer hardware, data-storage devices, and communications systems. Instead, the term “abstraction” refers, in the current discussion, to a logical level of functionality encapsulated within one or more concrete, tangible, physically-implemented computer systems with defined interfaces through which electronically-encoded data is exchanged, process execution launched, and electronic services are provided. Interfaces may include graphical and textual data displayed on physical display devices as well as computer programs and routines that control physical computer processors to carry out various tasks and operations and that are invoked through electronically implemented application programming interfaces (“APIs”) and other electronically implemented interfaces. There is a tendency among those unfamiliar with modern technology and science to misinterpret the terms “abstract” and “abstraction.” when used to describe certain aspects of modern computing. For example, one frequently encounters assertions that, because a computational system is described in terms of abstractions, functional layers, and interfaces, the computational system is somehow different from a physical machine or device. Such allegations are unfounded. One only needs to disconnect a computer system or group of computer systems from their respective power supplies to appreciate the physical, machine nature of complex computer technologies. One also frequently encounters statements that characterize a computational technology as being “only software,” and thus not a machine or device. Software is essentially a sequence of encoded symbols, such as a printout of a computer program or digitally encoded computer instructions sequentially stored in a file on an optical disk or within an electromechanical mass-storage device. Software alone can do nothing. It is only when encoded computer instructions are loaded into an electronic memory within a computer system and executed on a physical processor that so-called “software implemented” functionality is provided. The digitally encoded computer

instructions are an essential and physical control component of processor-controlled machines and devices, no less essential and physical than a cam-shaft control system in an internal-combustion engine. Multi-cloud aggregations, cloud-computing services, virtual-machine containers and virtual machines, communications interfaces, and many of the other topics discussed below are tangible, physical components of physical, electro-optical-mechanical computer systems.

**[0047]** FIG. 1 provides a general architectural diagram for various types of computers. The computer system contains one or multiple central processing units (“CPUs”) **102-105**, one or more electronic memories **108** interconnected with the CPUs by a CPU/memory-subsystem bus **110** or multiple busses, a first bridge **112** that interconnects the CPU/memory-subsystem bus **110** with additional busses **114** and **116**, or other types of high-speed interconnection media, including multiple, high-speed serial interconnects. These busses or serial interconnections, in turn, connect the CPUs and memory with specialized processors, such as a graphics processor **118**, and with one or more additional bridges **120**, which are interconnected with high-speed serial links or with multiple controllers **122-127**, such as controller **127**, that provide access to various different types of mass-storage devices **128**, electronic displays, input devices, and other such components, subcomponents, and computational resources. It should be noted that computer-readable data-storage devices include optical and electromagnetic disks, electronic memories, and other physical data-storage devices. Those familiar with modern science and technology appreciate that electromagnetic radiation and propagating signals do not store data for subsequent retrieval and can transiently “store” only a byte or less of information per mile, far less information than needed to encode even the simplest of routines.

**[0048]** Of course, there are many different types of computer-system architectures that differ from one another in the number of different memories, including different types of hierarchical cache memories, the number of processors and the connectivity of the processors with other system components, the number of internal communications busses and serial links, and in many other ways. However, computer systems generally execute stored programs by fetching instructions from memory and executing the instructions in one or more processors. Computer systems include general-purpose computer systems, such as personal computers (“PCs”), various types of servers and workstations, and higher-end mainframe computers, but may also include a plethora of various types of special-purpose computing devices, including data-storage systems, communications routers, network nodes, tablet computers, and mobile telephones.

**[0049]** FIG. 2 illustrates an Internet-connected distributed computing system. As communications and networking technologies have evolved in capability and accessibility, and as the computational bandwidths, data-storage capacities, and other capabilities and capacities of various types of computer systems have steadily and rapidly increased, much of modern computing now generally involves large distributed systems and computers interconnected by local networks, wide-area networks, wireless communications, and the Internet. FIG. 2 shows a typical distributed system in which a large number of PCs **202-205**, a high-end distributed mainframe system **210** with a large data-storage system

**212**, and a large computer center **214** with large numbers of rack-mounted servers or blade servers all interconnected through various communications and networking systems that together comprise the Internet **216**. Such distributed computing systems provide diverse arrays of functionalities. For example, a PC user sitting in a home office may access hundreds of millions of different web sites provided by hundreds of thousands of different web servers throughout the world and may access high-computational-bandwidth computing services from remote computer facilities for running complex computational tasks.

**[0050]** Until recently, computational services were generally provided by computer systems and data centers purchased, configured, managed, and maintained by service-provider organizations. For example, an e-commerce retailer generally purchased, configured, managed, and maintained a data center including numerous web servers, back-end computer systems, and data-storage systems for serving web pages to remote customers, receiving orders through the web-page interface, processing the orders, tracking completed orders, and other myriad different tasks associated with an e-commerce enterprise.

**[0051]** FIG. 3 illustrates cloud computing. In the recently developed cloud-computing paradigm, computing cycles and data-storage facilities are provided to organizations and individuals by cloud-computing providers. In addition, larger organizations may elect to establish private cloud-computing facilities in addition to, or instead of, subscribing to computing services provided by public cloud-computing service providers. In FIG. 3, a system administrator for an organization, using a PC **302**, accesses the organization’s private cloud **304** through a local network **306** and private-cloud interface **308** and also accesses, through the Internet **310**, a public cloud **312** through a public-cloud services interface **314**. The administrator can, in either the case of the private cloud **304** or public cloud **312**, configure virtual computer systems and even entire virtual data centers and launch execution of application programs on the virtual computer systems and virtual data centers in order to carry out any of many different types of computational tasks. As one example, a small organization may configure and run a virtual data center within a public cloud that executes web servers to provide an e-commerce interface through the public cloud to remote customers of the organization, such as a user viewing the organization’s e-commerce web pages on a remote user system **316**.

**[0052]** Cloud-computing facilities are intended to provide computational bandwidth and data-storage services such as utility companies provide electrical power and water to consumers. Cloud computing provides enormous advantages to small organizations without the resources to purchase, manage, and maintain in-house data centers. Such organizations can dynamically add and delete virtual computer systems from their virtual data centers within public clouds in order to track computational-bandwidth and data-storage needs, rather than purchasing sufficient computer systems within a physical data center to handle peak computational-bandwidth and data-storage demands. Moreover, small organizations can completely avoid the overhead of maintaining and managing physical computer systems, including hiring and periodically retraining information-technology specialists and continuously paying for operating-system and database-management-system upgrades. Furthermore, cloud-computing interfaces allow for easy and



straightforward configuration of virtual computing facilities, flexibility in the types of applications and operating systems that can be configured, and other functionalities that are useful even for owners and administrators of private cloud-computing facilities used by a single organization.

[0053] FIG. 4 illustrates generalized hardware and software components of a general-purpose computer system, such as a general-purpose computer system having an architecture similar to that shown in FIG. 1. The computer system 400 is often considered to include three fundamental layers: (1) a hardware layer or level 402; (2) an operating-system layer or level 404; and (3) an application-program layer or level 406. The hardware layer 402 includes one or more processors 408, system memory 410, various different types of input-output (“I/O”) devices 410 and 412, and mass-storage devices 414. Of course, the hardware level also includes many other components, including power supplies, internal communications links and busses, specialized integrated circuits, many different types of processor-controlled or microprocessor-controlled peripheral devices and controllers, and many other components. The operating system 404 interfaces to the hardware level 402 through a low-level operating system and hardware interface 416 generally comprising a set of non-privileged computer instructions 418, a set of privileged computer instructions 420, a set of non-privileged registers and memory addresses 422, and a set of privileged registers and memory addresses 424. In general, the operating system exposes non-privileged instructions, non-privileged registers, and non-privileged memory addresses 426 and a system-call interface 428 as an operating-system interface 430 to application programs 432-436 that execute within an execution environment provided to the application programs by the operating system. The operating system, alone, accesses the privileged instructions, privileged registers, and privileged memory addresses. By reserving access to privileged instructions, privileged registers, and privileged memory addresses, the operating system can ensure that application programs and other higher-level computational entities cannot interfere with one another’s execution and cannot change the overall state of the computer system in ways that could deleteriously impact system operation. The operating system includes many internal components and modules, including a scheduler 442, memory management 444, a file system 446, device drivers 448, and many other components and modules. To a certain degree, modern operating systems provide numerous levels of abstraction above the hardware level, including virtual memory, which provides to each application program and other computational entities a separate, large, linear memory-address space that is mapped by the operating system to various electronic memories and mass-storage devices. The scheduler orchestrates interleaved execution of various different application programs and higher-level computational entities, providing to each application program a virtual, stand-alone system devoted entirely to the application program. From the application program’s standpoint, the application program executes continuously without concern for the need to share processor resources and other system resources with other application programs and higher-level computational entities. The device drivers abstract details of hardware-component operation, allowing application programs to employ the system-call interface for transmitting and receiving data to and from communications networks, mass-storage devices, and other I/O devices and

subsystems. The file system 436 facilitates abstraction of mass-storage-device and memory resources as a high-level, easy-to-access, file-system interface. Thus, the development and evolution of the operating system has resulted in the generation of a type of multi-faceted virtual execution environment for application programs and other higher-level computational entities.

[0054] While the execution environments provided by operating systems have proved to be an enormously successful level of abstraction within computer systems, the operating-system-provided level of abstraction is nonetheless associated with difficulties and challenges for developers and users of application programs and other higher-level computational entities. One difficulty arises from the fact that there are many different operating systems that run within various different types of computer hardware. In many cases, popular application programs and computational systems are developed to run on only a subset of the available operating systems and can therefore be executed within only a subset of the various different types of computer systems on which the operating systems are designed to run. Often, even when an application program or other computational system is ported to additional operating systems, the application program or other computational system can nonetheless run more efficiently on the operating systems for which the application program or other computational system was originally targeted. Another difficulty arises from the increasingly distributed nature of computer systems. Although distributed operating systems are the subject of considerable research and development efforts, many of the popular operating systems are designed primarily for execution on a single computer system. In many cases, it is difficult to move application programs, in real time, between the different computer systems of a distributed computing system for high-availability, fault-tolerance, and load-balancing purposes. The problems are even greater in heterogeneous distributed computing systems which include different types of hardware and devices running different types of operating systems. Operating systems continue to evolve, as a result of which certain older application programs and other computational entities may be incompatible with more recent versions of operating systems for which they are targeted, creating compatibility issues that are particularly difficult to manage in large distributed systems.

[0055] For all of these reasons, a higher level of abstraction, referred to as the “virtual machine,” has been developed and evolved to further abstract computer hardware in order to address many difficulties and challenges associated with traditional computing systems, including the compatibility issues discussed above. FIGS. 5A-D illustrate several types of virtual machine and virtual-machine execution environments. FIGS. 5A-B use the same illustration conventions as used in FIG. 4. FIG. 5A shows a first type of virtualization. The computer system 500 in FIG. 5A includes the same hardware layer 502 as the hardware layer 402 shown in FIG. 4. However, rather than providing an operating system layer directly above the hardware layer, as in FIG. 4, the virtualized computing environment illustrated in FIG. 5A features a virtualization layer 504 that interfaces through a virtualization-layer/hardware-layer interface 506, equivalent to interface 416 in FIG. 4, to the hardware. The virtualization layer provides a hardware-like interface 508 to a number of virtual machines, such as virtual machine 510,

executing above the virtualization layer in a virtual-machine layer **512**. Each virtual machine includes one or more application programs or other higher-level computational entities packaged together with an operating system, referred to as a “guest operating system,” such as application **514** and guest operating system **516** packaged together within virtual machine **510**. Each virtual machine is thus equivalent to the operating-system layer **404** and application-program layer **406** in the general-purpose computer system shown in FIG. 4. Each guest operating system within a virtual machine interfaces to the virtualization-layer interface **508** rather than to the actual hardware interface **506**. The virtualization layer partitions hardware resources into abstract virtual-hardware layers to which each guest operating system within a virtual machine interfaces. The guest operating systems within the virtual machines, in general, are unaware of the virtualization layer and operate as if they were directly accessing a true hardware interface. The virtualization layer ensures that each of the virtual machines currently executing within the virtual environment receive a fair allocation of underlying hardware resources and that all virtual machines receive sufficient resources to progress in execution. The virtualization-layer interface **508** may differ for different guest operating systems. For example, the virtualization layer is generally able to provide virtual hardware interfaces for a variety of different types of computer hardware. This allows, as one example, a virtual machine that includes a guest operating system designed for a particular computer architecture to run on hardware of a different architecture. The number of virtual machines need not be equal to the number of physical processors or even a multiple of the number of processors.

[0056] The virtualization layer includes a virtual-machine-monitor module **518** (“VMM”) that virtualizes physical processors in the hardware layer to create virtual processors on which each of the virtual machines executes. For execution efficiency, the virtualization layer attempts to allow virtual machines to directly execute non-privileged instructions and to directly access non-privileged registers and memory. However, when the guest operating system within a virtual machine accesses virtual privileged instructions, virtual privileged registers, and virtual privileged memory through the virtualization-layer interface **508**, the accesses result in execution of virtualization-layer code to simulate or emulate the privileged resources. The virtualization layer additionally includes a kernel module **520** that manages memory, communications, and data-storage machine resources on behalf of executing virtual machines (“VM kernel”). The VM kernel, for example, maintains shadow page tables on each virtual machine so that hardware-level virtual-memory facilities can be used to process memory accesses. The VM kernel additionally includes routines that implement virtual communications and data-storage devices as well as device drivers that directly control the operation of underlying hardware communications and data-storage devices. Similarly, the VM kernel virtualizes various other types of I/O devices, including keyboards, optical-disk drives, and other such devices. The virtualization layer essentially schedules execution of virtual machines much like an operating system schedules execution of application programs, so that the virtual machines each execute within a complete and fully functional virtual hardware layer.

[0057] FIG. 5B illustrates a second type of virtualization. In FIG. 5B, the computer system **540** includes the same

hardware layer **542** and software layer **544** as the hardware layer **402** shown in FIG. 4. Several application programs **546** and **548** are shown running in the execution environment provided by the operating system. In addition, a virtualization layer **550** is also provided, in computer **540**, but, unlike the virtualization layer **504** discussed with reference to FIG. 5A, virtualization layer **550** is layered above the operating system **544**, referred to as the “host OS.” and uses the operating system interface to access operating-system-provided functionality as well as the hardware. The virtualization layer **550** comprises primarily a VMM and a hardware-like interface **552**, similar to hardware-like interface **508** in FIG. 5A. The virtualization-layer/hardware-layer interface **552**, equivalent to interface **416** in FIG. 4, provides an execution environment for a number of virtual machines **556-558**, each including one or more application programs or other higher-level computational entities packaged together with a guest operating system.

[0058] While the traditional virtual-machine-based virtualization layers, described with reference to FIGS. 5A-B, have enjoyed widespread adoption and use in a variety of different environments, from personal computers to enormous distributed computing systems, traditional virtualization technologies are associated with computational overheads. While these computational overheads have been steadily decreased, over the years, and often represent ten percent or less of the total computational bandwidth consumed by an application running in a virtualized environment, traditional virtualization technologies nonetheless involve computational costs in return for the power and flexibility that they provide. Another approach to virtualization is referred to as operating-system-level virtualization (“OSL virtualization”). FIG. 5C illustrates the OSL-virtualization approach. In FIG. 5C, as in previously discussed FIG. 4, an operating system **404** runs above the hardware **402** of a host computer. The operating system provides an interface for higher-level computational entities, the interface including a system-call interface **428** and exposure to the non-privileged instructions and memory addresses and registers **426** of the hardware layer **402**. However, unlike in FIG. 5A, rather than applications running directly above the operating system, OSL virtualization involves an OS-level virtualization layer **560** that provides an operating-system interface **562-564** to each of one or more containers **566-568**. The containers, in turn, provide an execution environment for one or more applications, such as application **570** running within the execution environment provided by container **566**. The container can be thought of as a partition of the resources generally available to higher-level computational entities through the operating system interface **430**. While a traditional virtualization layer can simulate the hardware interface expected by any of many different operating systems, OSL virtualization essentially provides a secure partition of the execution environment provided by a particular operating system. As one example, OSL virtualization provides a file system to each container, but the file system provided to the container is essentially a view of a partition of the general file system provided by the underlying operating system. In essence, OSL virtualization uses operating-system features, such as name space support, to isolate each container from the remaining containers so that the applications executing within the execution environment provided by a container are isolated from applications executing within the execution environments provided by all

other containers. As a result, a container can be booted up much faster than a virtual machine, since the container uses operating-system-kernel features that are already available within the host computer. Furthermore, the containers share computational bandwidth, memory, network bandwidth, and other computational resources provided by the operating system, without resource overhead allocated to virtual machines and virtualization layers. Again, however, OSL virtualization does not provide many desirable features of traditional virtualization. As mentioned above, OSL virtualization does not provide a way to run different types of operating systems for different groups of containers within the same host system, nor does OSL-virtualization provide for live migration of containers between host computers, as does traditional virtualization technologies.

**[0059]** FIG. 5D illustrates an approach to combining the power and flexibility of traditional virtualization with the advantages of OSL virtualization. FIG. 5D shows a host computer similar to that shown in FIG. 5A, discussed above. The host computer includes a hardware layer 502 and a virtualization layer 504 that provides a simulated hardware interface 508 to an operating system 572. Unlike in FIG. 5A, the operating system interfaces to an OSL-virtualization layer 574 that provides container execution environments 576-578 to multiple application programs. Running containers above a guest operating system within a virtualized host computer provides many of the advantages of traditional virtualization and OSL virtualization. Containers can be quickly booted in order to provide additional execution environments and associated resources to new applications. The resources available to the guest operating system are efficiently partitioned among the containers provided by the OSL-virtualization layer 574. Many of the powerful and flexible features of the traditional virtualization technology can be applied to containers running above guest operating systems including live migration from one host computer to another, various types of high-availability and distributed resource sharing, and other such features. Containers provide share-based allocation of computational resources to groups of applications with guaranteed isolation of applications in one container from applications in the remaining containers executing above a guest operating system. Moreover, resource allocation can be modified at run time between containers. The traditional virtualization layer provides flexible and easy scaling and a simple approach to operating-system upgrades and patches. Thus, the use of OSL virtualization above traditional virtualization, as illustrated in FIG. 5D, provides much of the advantages of both a traditional virtualization layer and the advantages of OSL virtualization. Note that, although only a single guest operating system and OSL virtualization layer as shown in FIG. 5D, a single virtualized host system can run multiple different guest operating systems within multiple virtual machines, each of which supports one or more containers.

**[0060]** A virtual machine or virtual application, described below, is encapsulated within a data package for transmission, distribution, and loading into a virtual-execution environment. One public standard for virtual-machine encapsulation is referred to as the “open virtualization format” (“OVF”). The OVF standard specifies a format for digitally encoding a virtual machine within one or more data files. FIG. 6 illustrates an OVF package. An OVF package 602 includes an OVF descriptor 604, an OVF manifest 606, an OVF certificate 608, one or more disk-image files 610-611,

and one or more resource files 612-614. The OVF package can be encoded and stored as a single file or as a set of files. The OVF descriptor 604 is an XML document 620 that includes a hierarchical set of elements, each demarcated by a beginning tag and an ending tag. The outermost, or highest-level, element is the envelope element, demarcated by tags 622 and 623. The next-level element includes a reference element 626 that includes references to all files that are part of the OVF package, a disk section 628 that contains meta information about all of the virtual disks included in the OVF package, a networks section 630 that includes meta information about all of the logical networks included in the OVF package, and a collection of virtual-machine configurations 632 which further includes hardware descriptions of each virtual machine 634. There are many additional hierarchical levels and elements within a typical OVF descriptor. The OVF descriptor is thus a self-describing XML file that describes the contents of an OVF package. The OVF manifest 606 is a list of cryptographic-hash-function-generated digests 636 of the entire OVF package and of the various components of the OVF package. The OVF certificate 608 is an authentication certificate 640 that includes a digest of the manifest and that is cryptographically signed. Disk image files, such as disk image file 610, are digital encodings of the contents of virtual disks and resource files 612 are digitally encoded content, such as operating-system images. A virtual machine or a collection of virtual machines encapsulated together within a virtual application can thus be digitally encoded as one or more files within an OVF package that can be transmitted, distributed, and loaded using well-known tools for transmitting, distributing, and loading files. A virtual appliance is a software service that is delivered as a complete software stack installed within one or more virtual machines that is encoded within an OVF package.

**[0061]** The advent of virtual machines and virtual environments has alleviated many of the difficulties and challenges associated with traditional general-purpose computing. Machine and operating-system dependencies can be significantly reduced or entirely eliminated by packaging applications and operating systems together as virtual machines and virtual appliances that execute within virtual environments provided by virtualization layers running on many different types of computer hardware. A next level of abstraction, referred to as virtual data centers which are one example of a broader virtual-infrastructure category, provide a data-center interface to virtual data centers computationally constructed within physical data centers. FIG. 7 illustrates virtual data centers provided as an abstraction of underlying physical-data-center hardware components. In FIG. 7, a physical data center 702 is shown below a virtual-interface plane 704. The physical data center consists of a virtual-infrastructure management server (“VI-management-server”) 706 and any of various different computers, such as PCs 708, on which a virtual-data-center management interface may be displayed to system administrators and other users. The physical data center additionally includes generally large numbers of server computers, such as server computer 710, that are coupled together by local area networks, such as local area network 712 that directly interconnects server computer 710 and 714-720 and a mass-storage array 722. The physical data center shown in FIG. 7 includes three local area networks 712, 724, and 726 that each directly interconnects a bank of eight servers and a

mass-storage array. The individual server computers, such as server computer **710**, each includes a virtualization layer and runs multiple virtual machines. Different physical data centers may include many different types of computers, networks, data-storage systems and devices connected according to many different types of connection topologies. The virtual-data-center abstraction layer **704**, a logical abstraction layer shown by a plane in FIG. 7, abstracts the physical data center to a virtual data center comprising one or more resource pools, such as resource pools **730-732**, one or more virtual data stores, such as virtual data stores **734-736**, and one or more virtual networks. In certain implementations, the resource pools abstract banks of physical servers directly interconnected by a local area network.

**[0062]** The virtual-data-center management interface allows provisioning and launching of virtual machines with respect to resource pools, virtual data stores, and virtual networks, so that virtual-data-center administrators need not be concerned with the identities of physical-data-center components used to execute particular virtual machines. Furthermore, the VI-management-server includes functionality to migrate running virtual machines from one physical server to another in order to optimally or near optimally manage resource allocation, provide fault tolerance, and high availability by migrating virtual machines to most effectively utilize underlying physical hardware resources, to replace virtual machines disabled by physical hardware problems and failures, and to ensure that multiple virtual machines supporting a high-availability virtual appliance are executing on multiple physical computer systems so that the services provided by the virtual appliance are continuously accessible, even when one of the multiple virtual appliances becomes compute bound, data-access bound, suspends execution, or fails. Thus, the virtual data center layer of abstraction provides a virtual-data-center abstraction of physical data centers to simplify provisioning, launching, and maintenance of virtual machines and virtual appliances as well as to provide high-level, distributed functionalities that involve pooling the resources of individual physical servers and migrating virtual machines among physical servers to achieve load balancing, fault tolerance, and high availability.

**[0063]** FIG. 8 illustrates virtual-machine components of a VI-management-server and physical servers of a physical data center above which a virtual-data-center interface is provided by the VI-management-server. The VI-management-server **802** and a virtual-data-center database **804** comprise the physical components of the management component of the virtual data center. The VI-management-server **802** includes a hardware layer **806** and virtualization layer **808** and runs a virtual-data-center management-server virtual machine **810** above the virtualization layer. Although shown as a single server in FIG. 8, the VI-management-server (“VI management server”) may include two or more physical server computers that support multiple VI-management-server virtual appliances. The virtual machine **810** includes a management-interface component **812**, distributed services **814**, core services **816**, and a host-management interface **818**. The management interface is accessed from any of various computers, such as the PC **708** shown in FIG. 7. The management interface allows the virtual-data-center administrator to configure a virtual data center, provision virtual machines, collect statistics and view log files for the virtual data center, and to carry out other, similar manage-

ment tasks. The host-management interface **818** interfaces to virtual-data-center agents **824**, **825**, and **826** that execute as virtual machines within each of the physical servers of the physical data center that is abstracted to a virtual data center by the VI management server.

**[0064]** The distributed services **814** include a distributed-resource scheduler that assigns virtual machines to execute within particular physical servers and that migrates virtual machines in order to most effectively make use of computational bandwidths, data-storage capacities, and network capacities of the physical data center. The distributed services further include a high-availability service that replicates and migrates virtual machines in order to ensure that virtual machines continue to execute despite problems and failures experienced by physical hardware components. The distributed services also include a live-virtual-machine migration service that temporarily halts execution of a virtual machine, encapsulates the virtual machine in an OVF package, transmits the OVF package to a different physical server, and restarts the virtual machine on the different physical server from a virtual-machine state recorded when execution of the virtual machine was halted. The distributed services also include a distributed backup service that provides centralized virtual-machine backup and restore.

**[0065]** The core services provided by the VI management server include host configuration, virtual-machine configuration, virtual-machine provisioning, generation of virtual-data-center alarms and events, ongoing event logging and statistics collection, a task scheduler, and a resource-management module. Each physical server **820-822** also includes a host-agent virtual machine **828-830** through which the virtualization layer can be accessed via a virtual-infrastructure application programming interface (“API”). This interface allows a remote administrator or user to manage an individual server through the infrastructure API. The virtual-data-center agents **824-826** access virtualization-layer server information through the host agents. The virtual-data-center agents are primarily responsible for off-loading certain of the virtual-data-center management-server functions specific to a particular physical server to that physical server. The virtual-data-center agents relay and enforce resource allocations made by the VI management server, relay virtual-machine provisioning and configuration-change commands to host agents, monitor and collect performance statistics, alarms, and events communicated to the virtual-data-center agents by the local host agents through the interface API, and to carry out other, similar virtual-data-management tasks.

**[0066]** The virtual-data-center abstraction provides a convenient and efficient level of abstraction for exposing the computational resources of a cloud-computing facility to cloud-computing-infrastructure users. A cloud-director management server exposes virtual resources of a cloud-computing facility to cloud-computing-infrastructure users. In addition, the cloud director introduces a multi-tenancy layer of abstraction, which partitions virtual data centers (“VDCs”) into tenant-associated VDCs that can each be allocated to a particular individual tenant or tenant organization, both referred to as a “tenant.” A given tenant can be provided one or more tenant-associated VDCs by a cloud director managing the multi-tenancy layer of abstraction within a cloud-computing facility. The cloud services interface (**308** in FIG. 3) exposes a virtual-data-center management interface that abstracts the physical data center.

[0067] FIG. 9 illustrates a cloud-director level of abstraction. In FIG. 9, three different physical data centers 902-904 are shown below planes representing the cloud-director layer of abstraction 906-908. Above the planes representing the cloud-director level of abstraction, multi-tenant virtual data centers 910-912 are shown. The resources of these multi-tenant virtual data centers are securely partitioned in order to provide secure virtual data centers to multiple tenants, or cloud-services-accessing organizations. For example, a cloud-services-provider virtual data center 910 is partitioned into four different tenant-associated virtual-data centers within a multi-tenant virtual data center for four different tenants 916-919. Each multi-tenant virtual data center is managed by a cloud director comprising one or more cloud-director servers 920-922 and associated cloud-director databases 924-926. Each cloud-director server or servers runs a cloud-director virtual appliance 930 that includes a cloud-director management interface 932, a set of cloud-director services 934, and a virtual-data-center management-server interface 936. The cloud-director services include an interface and tools for provisioning multi-tenant virtual data center virtual data centers on behalf of tenants, tools and interfaces for configuring and managing tenant organizations, tools and services for organization of virtual data centers and tenant-associated virtual data centers within the multi-tenant virtual data center, services associated with template and media catalogs, and provisioning of virtualization networks from a network pool. Templates are virtual machines that each contains an OS and/or one or more virtual machines containing applications. A template may include much of the detailed contents of virtual machines and virtual appliances that are encoded within OVF packages, so that the task of configuring a virtual machine or virtual appliance is significantly simplified, requiring only deployment of one OVF package. These templates are stored in catalogs within a tenant's virtual-data center. These catalogs are used for developing and staging new virtual appliances and published catalogs are used for sharing templates in virtual appliances across organizations. Catalogs may include OS images and other information relevant to construction, distribution, and provisioning of virtual appliances.

[0068] Considering FIGS. 7 and 9, the VI management server and cloud-director layers of abstraction can be seen, as discussed above, to facilitate employment of the virtual-data-center concept within private and public clouds. However, this level of abstraction does not fully facilitate aggregation of single-tenant and multi-tenant virtual data centers into heterogeneous or homogeneous aggregations of cloud-computing facilities.

[0069] FIG. 10 illustrates virtual-cloud-connector nodes ("VCC nodes") and a VCC server, components of a distributed system that provides multi-cloud aggregation and that includes a cloud-connector server and cloud-connector nodes that cooperate to provide services that are distributed across multiple clouds, VMware vCloud™ VCC servers and nodes are one example of VCC server and nodes. In FIG. 10, seven different cloud-computing facilities are illustrated 1002-1008. Cloud-computing facility 1002 is a private multi-tenant cloud with a cloud director 1010 that interfaces to a VI management server 1012 to provide a multi-tenant private cloud comprising multiple tenant-associated virtual data centers. The remaining cloud-computing facilities 1003-1008 may be either public or private cloud-computing

facilities and may be single-tenant virtual data centers, such as virtual data centers 1003 and 1006, multi-tenant virtual data centers, such as multi-tenant virtual data centers 1004 and 1007-1008, or any of various different kinds of third-party cloud-services facilities, such as third-party cloud-services facility 1005. An additional component, the VCC server 1014, acting as a controller is included in the private cloud-computing facility 1002 and interfaces to a VCC node 1016 that runs as a virtual appliance within the cloud director 1010. A VCC server may also run as a virtual appliance within a VI management server that manages a single-tenant private cloud. The VCC server 1014 additionally interfaces, through the Internet, to VCC node virtual appliances executing within remote VI management servers, remote cloud directors, or within the third-party cloud services 1018-1023. The VCC server provides a VCC server interface that can be displayed on a local or remote terminal, PC, or other computer system 1026 to allow a cloud-aggregation administrator or other user to access VCC-server-provided aggregate-cloud distributed services. In general, the cloud-computing facilities that together form a multiple-cloud-computing aggregation through distributed services provided by the VCC server and VCC nodes are geographically and operationally distinct.

[0070] Distributed Service-Oriented Applications, Node Attributes, Call Traces, and Metric Data

[0071] FIG. 11 illustrates a distributed service-oriented application. In FIG. 11, a number of servers, such as server 1102, are shown within a distributed computer system. The servers run various different services, such as front-end service 1104. Services are executables that provide functionality to other computational entities through a service interface, such as a RESTful application programming interface ("AP") accessed through network communications using REST-protocol requests, although many other communications protocols and programming interfaces can be used. A distributed service-oriented application can be considered to be a collection of various different services, running within virtual machines executing within servers of one or more distributed computer systems, that cooperate to implement a distributed application, although various different types of implementations are possible. The component services of the distributed application are often registered with a registration-and-subscription service 1106 to which other services can subscribe in order to receive updates with regard to the addition, removal, and changes to the array of available service components. In the example distributed service-oriented application illustrated in FIG. 11, a set of front-end-service instantiations 1104 and 1108-1111 communicate with remote clients and users through the Internet 1112 and communicate, via local-area networks and wide-area networks within the distributed computer system, with the many different service instantiations within the distributed computer system that together comprise the distributed service-oriented application, such as services 1116 and 1117 running within server 1118.

[0072] FIGS. 12A-B illustrate a sequence of service calls that implement a particular distributed-service-oriented-application API call or endpoint. In a first step 1202, a remote user or client sends a request to the distributed service-oriented application, resulting in a call to one of the front-end-service instances 1204. The front-end-service instance, in a second step 1206, calls a component-service instance 1208 in order to launch execution of the distributed-service-

oriented-application request-handling machinery for the received request. In FIG. 12A and in subsequent figures and discussions, the component services are referred to by alphanumeric labels, such as the label “S5” for the component service that includes the component-service instance 1208. In a third step 1210, component-service instance S5 calls component service S3 1212. In a fourth step 1214, component service S5 calls component-service instance S4 1216 which, in turn, calls component-service instance S6 1218 in a fifth step 1220. Component-service instance S6 then calls the additional component-service instances S8 1222, S9 1224, and S10 1226 in steps 1228 1229 and 1230, respectively. Each of the various component services carry out certain tasks and functionalities that contribute to execution of the user or client request. For example, component-service instance S5 1208 may receive and queue the request, call component-service instance S3 1212 to authenticate and authorize the request, and then call component-service instance S4 1216 to parse and to carry out the requested task. Component-service instance S6 1218 may handle a particular type of task or set of tasks, and may call data-storage-and-retrieval component-service instance S8 1222, a data-analysis component-service instance S9 1224, and a linear-algebra-computation component-service instance S10 1226, as one example. Each component-service instance call shown in FIG. 12A is associated with a relative timestamp, such as relative timestamp 1230 associated with the initial call to the front-end service 1204.

[0073] FIG. 12B illustrates a directed graph that represents the service calls, shown in FIG. 12A, that together comprise implementation of the distributed-service-oriented application API call or endpoint discussed with reference to FIG. 12A. In the case of the directed graph, or call trace, shown in FIG. 12B, the graph is generalized to represent calls made to services, rather than particular service instances. A service instance is a particular service executable running on a particular hardware device, while a service is the logical service, which may be implemented by one or more service instances. The instances that together comprise a particular service are referred to as a “node.” For example, in FIG. 11, five different front-end-service instances together implement the front-end service, or front-end-service node. The root node of the directed graph 1240 represents the initial call to the front-end service 1204. Each remaining node in the directed graph represents a service component called by another service component of the distributed service-oriented application. Each node contains an indication of the service component as well as a relative timestamp for the initial call to the service component. The directed graph shown in FIG. 12B is a relatively simple directed graph. However, in more complex distributed-service-oriented application API-call implementations, the directed graph may contain cycles and a larger number of nodes. The relative timestamps indicate the time order of service calls.

[0074] FIGS. 13A-B illustrate service components and service nodes. FIG. 13A illustrates a service component within a server of a distributed computing system. The server 1302 includes a hardware layer 1304, a virtualization layer 1306, and a virtual machine 1308, executing within the execution environment provided by the virtualization layer 1306. Of course, a server is a complex device that includes many thousands of hardware and computer-instruction-implemented components, not shown in high-level illustrations, such as FIG. 13A. Within the virtual machine, a guest

operating system 1310 executes and provides an execution environment for a service-component executable 1312. The hardware layer 1304 includes one or more communications interfaces, such as communications interface 1314, through which the server computer exchanges messages, such as message 1316, with remote computational entities via one or more local networks 1318 and, in some cases, wide-area networks. Network messages, for commonly used communications hardware and protocols, generally include a target Internet-protocol address 1320, which routes the messages to the communications interface 1314, as well as a port number 1322, which routes the message through the virtualization layer and guest operating system to a particular application, such as the service-component executable 1312. The service-component executable can carry out communications with many different remote computational entities, including, as further discussed below, a distributed call-trace service 1324. Dashed arrow 1325 represents an exchange of messages via the many internal components of the server and many external components between the server and the hardware on which the distributed call-trace service executes. Similarly, the virtualization layer can carry out communications with many different remote computational entities, including a VDC or VCC management server and distributed metrics-collection services 1326.

[0075] FIG. 13B illustrates a service node. A service node within the distributed computer system is a collection of the instances of the particular service, including the portions of the underlying server that support execution of the service instances. For example, in FIG. 13B, service node 1330 includes three service-component executables 1332-1334 running on servers 1336-1338. The VDC or VCC management servers and/or distributed metrics collection service can collect aggregate metrics 1340 for the service node and the distributed call-tracing service may collect call traces 1342 for service nodes. A service node is often a dynamic entity, since service-node instances may be shut down and removed, for example, under low workload conditions, and new service-node instances may be launched and initialized, for example, when workloads increase past a reasonable aggregate load on the current service-node instances. The service node is logically like a labeled container that can hold arbitrary numbers of service-node instances.

[0076] FIGS. 14A-C illustrate the scale of certain distributed-service-oriented-applications. In the simple example shown in FIG. 11, there are only a relatively small number of servers and component-service instances present. However, consider the more realistic computational environment inhabited by one or more distributed service-oriented applications shown in FIG. 14A. In a realistic distributed-computing-system environment, there may be literally hundreds or thousands of server computers supporting concurrent execution of tens, hundreds, or more different distributed service-oriented applications. As shown in FIG. 14B, the service-component instances for the distributed service-oriented application discussed with reference to FIG. 11 may be widely dispersed throughout hundreds or thousands of servers that include many additional instances of the same types of service components employed by the distributed service-oriented application used by other distributed service-oriented applications. It is even possible that multiple distributed service-oriented applications share particular instances of certain of the service components. The service-component instances associated with the distributed service-

oriented application discussed with reference to FIG. 11 are marked with surrounding ellipses in FIG. 14B. It would be a challenging task to identify them, among hundreds or thousands of other instances of the same types of services, let alone figure out how they cooperate to provide the distributed-service-oriented-application API.

[0077] FIG. 14C illustrates an example directed graph representing the topology of a distributed service-oriented application. Each node in the graph corresponds to a service node and the arrows indicate calls made by service nodes to other service nodes. The directed graph may include many different subgraphs, such as a sub graph corresponding to the call trace shown in FIG. 12B, for the various different entrypoints of the distributed-services-oriented-application API. For example, the subgraph corresponding to the call trace shown in FIG. 12B consists of nodes 1402-1409. A different entrypoint might be implemented by the subgraph comprising nodes 1402 and 1410-1412. The problem domain to which the current document is directed is the problem of attempting to determine causes of, or subsets of the components of a distributed computer system relevant to, particular operational anomalies detected from metric data in complex distributed-computing environments, including distributed-computing environments supporting large, complex, distributed, service-oriented applications. Currently available diagnostic methods may be inefficient, provide unmanageably complex user interfaces, and may lack sufficiently focused, analytical approaches to providing productive suggestions for potential causes of anomalous operational behaviors of distributed-computer systems and distributed-computer-system components.

[0078] FIGS. 15A-B illustrate components of a call-tracing service. FIG. 15A illustrates, using the same illustration conventions used in FIG. 13A, the call-tracing components included in servers and other computational platforms supporting the execution of distributed-service-oriented-application components. Virtual machine 1502 within server 1504 supports execution of two different service instances 1506 and 1508. Each service instance, or service application, includes a trace client 1510-1511. The trace clients communicate with a trace agent 1512 that runs in the execution environment provided by the virtual machine 1502. The trace clients represent generally minimal instrumentation included in service applications to support call tracing. Many modern service applications are designed and developed to support call tracing, and include generalized trace clients that can communicate with a variety of different types of trace agents provided by different call-tracing services.

[0079] FIG. 15B illustrates additional components of a call-tracing service. The trace agents 1520-1522 in multiple servers 1524-1526 that support execution of a distributed service-oriented application communicate with a centralized trace collector 1528 that collects and processes trace data received from the trace agents and stores the processed data in a trace database 1530. The trace collector may be a single executable or may be a distributed application. A query service 1532 accesses the trace database on behalf of remote clients 1534 to display traces 1536 corresponding to the submitted queries. Thus, for example, a system administrator working to understand some type of operational anomaly detected within a distributed computer system may submit a query to the query service for particular subsets of the traces

collected by the tracing service that the system administrator believes to be relevant to the operational anomaly.

[0080] FIGS. 16A-H illustrate how the tracing service, discussed above with reference to FIGS. 15A-B, collects a call trace. FIGS. 16A-H all use the same illustration conventions, next described with respect to FIG. 16A. FIG. 16A shows four different servers 1602-1605 that each includes a service instance 1606 containing a trace client 1608 and a trace agent 1610. As shown in FIG. 16A, a remote client of a distributed service-oriented application 1612 requests a service, as represented by curved arrow 614. When the service instance 1606 receives the request, the service instance invokes the trace client 1608 to send tracing information related to the service request to the trace agent 1610. The trace agent packages the information into a new-request message 1616 that is transmitted to the trace collector 1618 of a call-tracing service. The new-request message may contain an indication that the message is a new-request message, identifiers for the service application, host server computer, and the called distributed-service-oriented-application entrypoint, a timestamp indicating the time that the service request was received, and whatever additional information is collected by the trace client and trace agent. The trace collector launches a new call trace, including generating a unique trace identifier for the new call trace, and stores information extracted from the new-request message into a first call-trace frame 1620 stored within memory, a persistent store, or both memory and a persistent store, depending on the implementation. As shown in FIG. 16B, the trace collector returns the trace identifier 1622 to the trace agent 1610 which, in certain implementations, returns the trace identifier to the trace client 1608 so that the trace identifier can be included in subsequent messages relevant to the trace sent by various trace agents within servers supporting execution of service instances of the distributed service-oriented application that cooperate to execute the service request on behalf of the remote client.

[0081] As shown in FIG. 16C, while executing the service request, service instance 1606 makes an internal service-request call to service instance 1624. When making this service request, service instance 1606 invokes the trace client 1608 to include the trace identifier for the service request in the request message 1626 sent to service instance 1624. When service instance 1624 receives the request message, the trace client 1628 within service instance 1624 forwards relevant information about the service request to the trace agent 1630 within the server 1632 that hosts service instance 1624. The trace agent, in turn, forwards a span message 1634 to the trace collector 1618. The trace collector uses the trace identifier within the span message to locate the stored call trace and to add, to the stored call trace, a second call-trace frame 1636. As shown in FIG. 16D, when the service instance 1624 subsequently makes a service request to service instance 1638 during execution of the service request 1626 received from service instance 1606, service instance 1638 invokes the trace client 1642 to transmit service-request information to trace agent 1642, which, in turn, forwards a span message 1644 to the trace collector 1618. The trace collector uses information in the span message to add a third trace-call frame 1646 to the stored call trace corresponding to the trace identifier received in the service request 1648. FIG. 16E illustrates a final span message 1650 transmitted as a result of a service request 1652 made by the service instance 1638 to service instance



**1654.** The final span message **1650** is used to add a fourth call-trace frame **1656** to the stored call trace within the trace collector **1618**.

**[0082]** As shown in FIG. 16F, when service instance **1654** completes executing the service request, the trace client **1658** is invoked to communicate termination of the request to the trace agent **1660**, which sends a span-terminate message **1662** to the trace collector **1618**. The trace collector adds a completion or termination timestamp **1664** to the final call-trace frame **1656**, thus completing the final call-trace frame. As each service instance in the stack of service instances contributing to execution of the original service request finishes its internal request, each service instance invokes its trace client to transmit information to the corresponding trace agent so that the trace agent forwards a span-terminate message to the trace collector **1618**. FIG. 16G illustrates sending of a final message by the first service instance **1606** in the stack of service instances via the trace client **1608** and trace agent **1610**. In this case, the trace agent sends an end-request message **1666**, rather than a span-terminate message, to the trace collector **1618**, which adds the final timestamp **1668** to the first call-trace frame **1620**. Then, as shown in FIG. 16H, the trace collector encodes the completed call trace into an encoded-trace message **1670** which is forwarded to the trace database (**1530** in FIG. 15B) for storage.

**[0083]** Of course, there are a variety of different ways to implement a call-tracing service. The above discussion with reference to FIGS. 15A-16H is intended to describe one of the many possible approaches.

**[0084]** FIG. 17 illustrates distributed-computing-system-component attributes and attribute values. In the example shown in FIG. 17, attribute values are associated with service instances. As mentioned above with reference to FIG. 11, in many modern distributed service-oriented applications, the service instances register with a service-instance registration-and-subscription service (**1106** in FIG. 11). In the attribute-value-assignment system illustrated in FIG. 17, when a service instance registers with the service-instance registration-and-subscription service, the service instance includes formatted attribute/attribute-value pairs in the registration message sent to the service-instance registration-and-subscription service. The service-instance registration-and-subscription service **1702** then encodes the attribute/attribute-value pairs in a formatted text message, such as a JSON encoding of the attribute/attribute-value pairs **1704**, and transmits the text message to an attribute-value-collector component **1706** of an attribute service, which stores the attribute values in an attribute database **1708**. The attribute service also provides an attribute-query service **1710** which allows system administrators and other privileged personnel to view the attribute values associated with one or more service instances. An attribute service may similarly provide attribute-value storage and query services for other types of distributed-computer-system components. Many alternate methods for attribute-value collection, storage, and retrieval are possible.

**[0085]** FIG. 18 illustrates a simple example of the generation and collection of status, informational, and error data the distributed computing system. In FIG. 18, a number of computer systems **1802-1806** within a distributed computing system are linked together by an electronic communications medium **1808** and additionally linked through a communications bridge/router **1810** to an administration

computer system **1812** that includes an administrative console **1814**. As indicated by curved arrows, such as curved arrow **1816**, multiple components within each of the discrete computer systems **1802** and **1806** as well as the communications bridge/router **1810** generate various types of status, informational, and error data that is encoded within event messages which are ultimately transmitted to the administration computer **1812**. Event messages are but one type of vehicle for conveying status, informational, and error data, generated by data sources within the distributed computer system, to a data sink, such as the administration computer system **1812**. Data may be alternatively communicated through various types of hardware signal paths, packaged within formatted files transferred through local-area communications to the data sink, obtained by intermittent polling of data sources, or by many other means. The current example, the status, informational, and error data, however generated and collected within system subcomponents, is packaged in event messages that are transferred to the administration computer system **1812**. Event messages may be relatively directly transmitted from a component within a discrete computer system to the administration computer or may be collected at various hierarchical levels within a discrete computer and then forwarded from an event-message-collecting entity within the discrete computer to the administration computer. The administration computer **1812** may filter and analyze the received event messages, as they are received, in order to detect various operational anomalies and impending failure conditions. In addition, the administration computer collects and stores the received event messages in a data-storage device or appliance **1818** as large event-message log files **1820**. Either through real-time analysis or through analysis of log files, the administration computer may detect operational anomalies and conditions for which the administration computer displays warnings and informational displays, such as the warning **1822** shown in FIG. 18 displayed on the administration-computer display device **1814**.

**[0086]** FIG. 19 shows a small, 11-entry portion of a log file from a distributed computer system. In FIG. 19, each rectangular cell, such as rectangular cell **1902**, of the portion of the log file **1904** represents a single stored event message. In general, event messages are relatively cryptic, including generally only one or two natural-language sentences or phrases as well as various types of file names, path names, and, perhaps most importantly, various alphanumeric parameters. For example, log entry **1902** includes a short natural-language phrase **1906**, date **1908** and time **1910** parameters, as well as a numeric parameter **1912** which appears to identify a particular host computer.

**[0087]** FIG. 20 illustrates one initial event-message-processing approach. In FIG. 20, a traditional event log **2002** is shown as a column of event messages, including the event message **2004** shown within inset **2006**. Automated subsystems may process event messages, as they are received, in order to transform the received event messages into event records, such as event record **2008** shown within inset **2010**. The event record **2008** includes a numeric event-type identifier **2012** as well as the values of parameters included in the original event message. In the example shown in FIG. 20, a date parameter **2014** and a time parameter **2015** are included in the event record **2008**. The remaining portions of the event message, referred to as the “non-parameter portion of the event message,” is separately stored in an entry in a table



of non-parameter portions that includes an entry for each type of event message. For example, entry **2018** in table **2020** may contain an encoding of the non-parameter portion common to all event messages of type a12634 (**2012** in FIG. **20**). Thus, automated subsystems may transform traditional event logs, such as event log **2002**, into stored event records, such as event-record log **2022**, and a generally very small table **2020** with encoded non-parameter portions, or templates, for each different type of event message.

**[0088]** FIGS. **21A-B** illustrate one of many different possible ways of storing attribute values for system components and metric values for system components generated from event messages or event records. FIG. **21A** shows three simple relational-database tables **2102-2104** that are used to store attribute values for system components in one implementation of the attribute database discussed above with reference to FIG. **17**. The table **Attributes 2102** stores, for each attribute, an identifier, and alphanumeric name, and a type. In this example, attributes may have discrete values or integral values within a range of values. The table **Discrete\_Attribute\_Values 2103** stores the possible discrete values for attributes of the discrete type and the table **Integral\_Attribute\_Values 2104** stores the numeric range for attributes of the integral type. These tables may be accessed using structured query language (“SQL”) queries or via programs with embedded SQL queries. Pseudocode examples for various data-access routines are provided in the lower left portion of FIG. **21A**. The routine **getID 2106** returns the identifier for an attribute corresponding to an attribute name furnished as an argument. The routine **getType 2108** returns the type of an attribute corresponding to an attribute name furnished as an argument. The routine **getNum 2110** returns a number of possible values for an attribute corresponding to an attribute name furnished as an argument.

**[0089]** FIG. **21B** shows additional relational-database tables that can be used to store indications of the attributes associated with various system components and metric values collected for various system components within a distributed computer system. The table **Components 2120** stores an identifier, a name, and a type or each of the system components. The table **Component\_Relationships 2122** stores relationships between pairs of components, with the relationships including contains and contained\_within. The table **Component\_Attributes 2124** stores attribute values for the attributes of various system components. The table **Metrics 2126** stores an identifier and name for each of the different metrics collected for system components and the table **Metric\_Values 2128** stores timestamped metric values collected from event messages or event records for system components. FIGS. **21A-B** are intended to illustrate one possible approach to storing attribute values and metric values for the components of a distributed computer system, but many other approaches are possible.

**[0090]** FIGS. **22A-B** illustrates detection of the system-component operational anomalies using metric data. In the two-dimensional plot **2202** shown in FIG. **22A**, each point, such as point **2204**, represents a metric value collected at a particular point in time, with the vertical axis **2206** presenting metric values and the horizontal axis **2208** representing time. The metric values in this plot quickly rise from the origin **2210** to a stable metric-value range **2212** within which the metric values vary over time. However, at time point **2214**, the value of the collected metric **2216** has risen above the stable value range and rises again to a series of

higher values **2218** at subsequent time points. The sudden departure from a stable value range may be identified as an anomaly. Anomaly detection can be automatically carried out by computing various statistical quantities and looking for values of the statistical quantities that fall above or below particular threshold values. For example, the metric values may be normally distributed about a mean, as represented by the curve plotted in plot **2220** in the lower left portion of FIG. **22A**. The curve **2222** represents the distribution of values about the mean **2224** and the horizontal axis **2226** is incremented in standard deviations. The mean is calculated from accumulated metric values as indicated by expression **2230**, the variance is calculated via expression **2232**, and the standard deviation is the square root of the variance, as indicated by expression **2234**. A z-statistic **2236** represents the distance, in standard deviations, of a metric value from the mean. One method of detecting anomalies is to compute the z-statistic for metric values and identify metric values with absolute z-statistic values greater than or equal to some threshold value to be potentially anomalous. Of course, metric values may include a significant amount of noise, and additional considerations may be employed to separate likely anomalies from potentially anomalous metric values, including various computed statistics indicating the probability of encountering anomalous z-statistic values, the distributions of potentially anomalous values, co-occurrences of potentially anomalous values of one metric with potentially anomalous values of other metrics, trends in metric values over time, and many other considerations. FIG. **22B** illustrates a different type of anomaly that may be automatically detected. Plot **2240** shows metric values plotted with respect to time, as in plot **2202** in FIG. **22A**. In this case, the metric values regularly oscillate up through the metric value **2242** recorded at time **2244**. Thereafter, there is no apparent regular pattern to the distribution of metric values respect to time. This type of anomaly may be detected by determining a prediction function that predicts the next metric value based on the metric values preceding that metric value, in time **2246**. When the absolute value of the difference between the observed value and predicted value for a metric is greater than or equal to a threshold value, a potential anomaly is indicated **2248**. The example shown in FIGS. **22A-B** are meant to provide illustrations of a few of the many different possible types of metric-value-anomaly indications and methods for automatically detecting these indications. There is a very large literature concerning time-series-data analysis and anomaly detection, with many sophisticated approaches to detecting many different types of anomalies are described in this literature.

#### Dimensional-Analysis Methods and Systems

**[0091]** In the previous subsection of this document, a number of components of the currently disclosed methods and systems have been described. Call-tracing services are currently commercially available. Event-message collection, logging, and analysis, and generation of metric data from collected and processed event messages, are also well known, with many currently commercially available data collection and analysis products used for administration and management of distributed computer systems. Although systems for associating attribute values with distributed-system components may not be currently commercially available, there are many different types of attributes-based and attribute-value-based systems and technologies used in

computing, with standard methods of encoding attribute/attribute-value pairs, such as JSON, well known in modern technology. The currently disclosed methods and systems employ metric data, call traces, and attribute values associated with system components in order to identify likely root causes or likely relevant attribute dimensions for identified anomalies in the operational behavior of one or more components of a distributed computer system and, in particular, to identify root causes and likely relevant attribute dimensions for the service-oriented-application components of distributed service-oriented applications. While analysis of metric data and call traces have been employed separately and in combination for attempting to determine the causes of anomalous operational behaviors of system components of distributed computer systems, the currently disclosed methods and systems use metric data, call traces, and component-associated attributes, along with efficient analytical methods, to efficiently and reliably identify root causes of, and likely attribute dimensions relevant to, various types of anomalies within distributed computer systems.

[0092] FIGS. 23A-K illustrate one example of the currently disclosed methods for determining root causes of, and attribute dimensions that are likely to be relevant to, detected anomalies within distributed heating systems. In this example, as shown in FIG. 23A, a relatively small, simple distributed computer system includes four levels of server computers 2302-2305. The server computers in the first level 2302, such as server computer 2306, each includes a service instance of a service node A, such as service instance 2307 in server computer 2306. Attribute values for three attributes are maintained by an attribute service and via call traces for each of the service-A-node instances. The three attributes include: (1) version, the version number for the service-instance implementation; (2) geo, the geographical region from which service requests are received by the service-A-node instances; and (3) server, or host, the identity of the server or host on which the service-A-node instance runs. Each service-A-node instance is associated with a version-attribute value, a geo-attribute value, and a server attribute value. For example, for service-A-node instance 2307 and server 2306, the version-attribute value is "1.1" 2308, the label "geo" indicates that the requests received by the service-A-node instances are associated with geographical-region values, and the service-A-node instance 2307 runs on a server "s<sub>1</sub>," as indicated by the label "s<sub>1</sub>." The label "A" 2309 indicates the service-oriented-application type, or node, to which the service instance 2307 belongs and the label "s<sub>1</sub>" is an identifier for server 2306. In this example, there are five different geographical regions: NW, SW, MW, NE, and S. Cloud 2310 indicates that server 2306 receives service requests from the NE and S geographical regions. The servers in layer 2303 each contains a service instance of a service-B node and a service instance of a service-C node. The servers in layer 2304 each contains a service instance of the service-D node and a service instance of the service-E node. The servers in layer 2305 each contains a service instance of the service-F node. Each instance of the services B, C, D, E, and F is associated with a version attribute, as described above for the instances of service A, a configuration attribute that has values S, M, and F indicating a minimal, standard, or full configuration with respect to allocated memory, networking, and processor-bandwidth resources, and a server attribute, as discussed above with reference to instances of service A. Arrows, such as arrow

2311, indicate networking links or paths that connect remote service-requesting entities to first-level servers that internally connect servers of one level to servers of another level. Although single-headed arrows are used for the links, the links are all, of course, bi-directional.

[0093] FIG. 23B shows three different call-trace patterns corresponding to three different types of service requests that are received and executed by the distributed service-oriented application comprising instances of nodes A, B, C, D, E, and F. For the first type of service request, the service request is received by an instance of node A 2312 which, in turn, requests an internal service from an instance of node B 2313. When that internal service request completes, the result is returned to the instance of node A 2312. For the second type of service request, the service request is received by an instance of node A 2314 which, in turn, requests an internal service from an instance of application service C 2315 which, in turn, requests an internal service from an instance of application service D 2316. The third type of service request is received by an instance of node A and executed by successive internal requests to nodes C 2318, E 2319, and F 2320. In this example, node F is a persistent-storage service that stores data in a database. In an initial series of internal requests, among other things, the data is passed to an instance of node F, which prepares the database for a commit operation. In a second series of internal requests, the node F receives a confirmation indication allowing the commit operation to proceed so that the data is persistently stored as part of an atomic transaction.

[0094] As shown in FIG. 23C, the attributes associated with the node instances can be thought of as dimensions of a three-dimensional attribute-value space associated with the node. The attribute-value space is represented by a series of two-dimensional sections. For example, node A comprises five node instances 2321 and is represented by a three-dimensional attribute-value space 2322 comprising five two-dimensional sections, four of which 2323-2326 are shown in FIG. 23C, each corresponding to a different geographical region. Each two-dimensional section, such as two-dimensional section 2323, includes rows corresponding to version-attribute values and columns corresponding to server-attribute values. A similar representation of a three-dimensional attribute-value space 2327 includes two-dimensional sections, each corresponding to a configuration-attribute value, with each two-dimensional section including rows corresponding to version-attribute values and columns corresponding to server-attribute values.

[0095] FIG. 23D illustrates an initial detection of an operational anomaly within the distributed service-oriented application and distributed computer system discussed above with reference to FIGS. 23A-C. As shown in FIG. 23D, the node-F instance running on server s<sub>1,7</sub> has exhibited anomalous operational behavior as a result of a commit\_time\_outs metric value that exceeds a threshold value. This metric value represents the number of commit timeouts in a recent time interval due to failures to receive confirmations from service-A nodes allowing persistent storage of received data within the database. The darkened cell 2328 in the representation of the attribute-value space 2329 indicates the detected anomalous operational behavior of the node-F instance running on server s<sub>1,7</sub>. Of course, the initial indication of a problem with a single node-F instance provides little information about the ultimate cause of the failure. The failure may represent a hardware problem with server s<sub>1,7</sub>, a

problem with the database used by node F for storing transaction data, problems with any of the intermediate nodes in forwarding confirmation messages from node A to node F, various types of networking problems, or many other more complex problems.

**[0096]** Next, as shown in FIG. 23E, additional anomalous operational behavior is detected in node-F instances **2330** and **2331**. At this point in time, it is clear that a serious problem may be developing within the distributed service-oriented application. The problem is not specific to any single server, since the problem-associated node-F instances are distributed across the server-attribute dimension. Similarly, because the problem-associated node-F instances are distributed across the version-attribute dimension, the problem has not arisen as a result of a single-version implementation bug. No other anomalous behaviors have been detected in any of the other nodes, so there is very little information available to a system administrator or automated management system with regard to what may be causing the increasingly serious anomalous operational behavior within the distributed service-oriented application.

**[0097]** FIG. 23F illustrates the recent call traces that had been collected by the call-trace service which include spans touching one of the three failing node-F instances running on servers  $s_{17}$ ,  $s_{18}$ , and  $s_{21}$ . As mentioned above, the query service provided by the call-tracing service allows a system administrator, other professional, or an automated management system to retrieve collected call traces defined by one or more query parameters. The call traces are abbreviated to only the initial downward path of service requests and internal service requests that include nodes A, C, E, and F. One approach to attempting to analyze the anomalous operational behavior of the distributed service-oriented application is to use the relevant call traces, shown in FIG. 23F, to annotate the dimensional representations of the other nodes observed in the call traces. The other nodes that occur in call traces ending with the three failing node-F instances running on servers  $s_{17}$ ,  $s_{18}$ , and  $s_{21}$  may be, in some way, related to the observed anomalous operational behaviors of these failing node-F instances.

**[0098]** FIG. 23G shows, using crosshatching, the other node instances of the currently call traces shown in FIG. 23F. The crosshatched cells of the representations of the three-dimensional attribute-value space associated with the other nodes correspond to these other node-instances observed in the call traces. First, consider the three-dimensional attribute-value space **2334** for node E. The node-E instances that occur in the call traces are clearly distributed across the server-attribute dimension, the version-attribute dimension, and the configuration-attribute dimension. There is no indication, in the pattern of marked cells within the representation of the three-dimensional attribute-value space **2334** for node E, that any particular subset of the node E instances might be responsible for the failures observed in the three failing node-F instances. Similar comments apply to the crosshatched cells in the three-dimensional attribute-value space **2335** for node C and even more clearly apply to the crosshatched cells in the three-dimensional attribute-value space **2336** for node A. Thus, the subset of recently collected traces that include spans touching the three failing node-F instances, shown in FIG. 23F, fail to provide useful information with respect to the root cause of the anomalous operational behavior.

**[0099]** FIG. 23H shows a representation of the full set of the most recent collected call traces for the distributed service-oriented application. The call traces shown in FIG. 23F are a subset of the full set of the most recent collected call traces. At this point, a decision-tree-like analysis may be attempted on the set of call traces shown in FIG. 23H in order to identify attribute dimensions that may explain the three failing node-F instances. In this approach, each of the different node dimensions is considered in order to find a decision-tree-node expression that will partition the full set of call traces into a set of call traces that includes only the three failing node-F instances. Consideration of the first node dimension, which is the host attribute for node A, is shown in FIG. 23I. First, the expression “A.host=1” is used in the first node **2338** of a decision tree. When the expression evaluates to TRUE for a call trace, the node-F instance in the call trace, if there is a node-F instance in the call trace, is placed in a left-hand set **2339**. When the expression evaluates to FALSE for a call trace, if there is a node-F instance in the call trace, the node-F instance in the call trace is placed in a right-hand set **2340**. As can be seen in FIG. 23I, the expression “A.host=1” in the first node of the decision tree does not produce the set of servers  $s_{17}$ ,  $s_{18}$ , and  $s_{21}$  in the left-hand set. It does produce the set of servers  $s_{17}$  and  $s_{18}$ , which means that the expression “A.host=1” may be, in part, relevant to the explanation of the failing of the three node-F instances, but is not the whole story. When the other single-value expressions for the server attribute of node A are tried for the expression in the root node of the decision tree, only the expression “A.host=5” **2341** produces a left-hand set that includes failing node-F instances, but like the expression “A.host=1,” the expression “A.host=5” fails to produce the full set of failing node-F instances. FIG. 23J illustrates first nodes of possible decision trees that include expressions containing multiple values for the first attribute dimension. Not surprisingly, only the expression “A.host=1 OR A.host=5” **2342** leads to the desired left-hand set **2344**. This is an indication that the failure of the three node-F instances may be related to the node-A instances running on servers  $s_1$  and  $s_5$ .

**[0100]** FIG. 23K illustrates the decision-tree-like analysis using the second node dimension geo. A decision tree **2345** with a first node including the expression “geo=NE” produces the desired set of node-F instances **2346**. The expression “geo=NE” is simpler than the expression “A.host=1 AND A.host=5,” and thus may constitute more relevant information with regard to the cause of the observed node F-instance failures. The analysis carried out by the currently disclosed methods and systems seeks simple and powerful dimensional explanations of the observed pattern of operational-behavior anomalies. In the current example, the expression “geo=NE” it is, in fact, the best clue, or indication, of the root cause of the three failing node F nodes, which is correlated with the geo dimension.

**[0101]** In this example, the underlying cause of the commit failures in the three node F-instances running on servers  $s_{17}$ ,  $s_{18}$ , and  $s_{21}$  is a problem with network transmissions from the region NE. 10% of the messages sent from remote clients in the NE region to the node-A instances running on servers  $s_1$  and  $s_5$  are lost or dropped. These are the only servers that receive messages from the NE region. Messages that are lost and dropped during back-end-fourth communications within transactions are handled by the node-A instances resending messages for which responses were

expected. Since 90% of these resent messages receive responses, only 1% of the response messages fail repeatedly. Because only repeatedly failing response messages result in commit timeouts, only the node-F instance running on server  $s_{17}$  initially experienced a sufficient number of commit timeouts to exceed the warning-level metric, as shown in FIG. 23D. This is because roughly half of the internal service requests received by the node-F instance running on server  $s_{17}$  are made as a result of remote-client requests from region NE arriving at the node-A instances running on servers  $s_1$  and  $s_5$ . Eventually, the node-F instances running on servers  $s_{18}$  and  $s_{21}$ , for each of which roughly a quarter of the received internal service requests are made as a result of remote-client requests from region NE, experienced a sufficient number of commit timeouts to exceed the warning-level metric, as shown in FIG. 23E. Since the failing node-F instances running on servers  $s_{17}$ ,  $s_{18}$ , and  $s_{21}$  all receive internal requests made as a result of remote-client requests from regions other than region NE, there was no discernible pattern in the attribute dimensions of the node-A instances, as shown in FIG. 230. Of course, had the attribute dimensions for the node-A instances included a message-retry-above-threshold attribute collected by the call-tracing service, an indicative pattern in that dimension may have been observed, as a result of which a likely relevant dimension would have been identified from the call-trace subset shown in FIG. 23F. However, because there was no such attribute dimension for the node-A instances, the likely relevant geo dimension was only identified from the full set of call traces, shown in FIG. 23H, and the decision-tree-based analysis discussed with reference to FIGS. 23I-K. This example shows that dimensional patterns may emerge in nodes that are not adjacent to nodes identified as exhibiting anomalous operational behavior in the collected call traces, and even quite far removed from the problem nodes. In this example, no anomalous operational behaviors were identified in intermediate nodes C and E, and no dimensional patterns were evident in these nodes.

[0102] FIGS. 24A-B illustrate a second example of application of the currently disclosed methods for determining root causes of, and attributes that are likely to be relevant to, detected anomalies within distributed heating systems. The distributed service-oriented application shown in FIG. 24A is similar to that shown in FIG. 23A, with the exception that the servers at each level are more densely connected with servers at adjacent levels. As shown in FIG. 24B, `commit_time_outs` warnings are observed for the node-F instances running on servers  $s_{19}$ ,  $s_{20}$ , and  $s_{21}$ , as indicated by the shaded cells 2402-2404 in the representation of the attribute-value space 2406 for node F. Using only the recent collected call traces that include the node-F instances running on servers  $s_{18}$ ,  $s_{19}$ , and  $s_{20}$ , as shown for the first example in FIG. 23F, crosshatching is used to mark the instances of nodes E, C, and A observed in the recent collected call traces that include the node-F instances running on servers  $s_{19}$ ,  $s_{20}$ , and  $s_{21}$ . As can be seen in FIG. 24B, the marked instances of node A are distributed across the geo-attribute dimension, but are relatively spatially confined in the version-attribute and server-attribute dimensions. This pattern would suggest that the node-A instances running on servers  $s_2$  and  $s_3$  may be related to the failures of the node-F instances running on servers  $s_{18}$ ,  $s_{19}$ , and  $s_{21}$ . There is only one marked instance of node C, which strongly indicates that the node C instance running on server  $s_4$  may be correlated with the failures of

the node-F instances running on servers  $s_{18}$ ,  $s_{19}$ , and  $s_{20}$ . The marked node E instances are clustered across two different servers and two different versions, again showing indications that the node E instances running on servers  $s_{13}$  and  $s_{14}$  may be related to the failures of the node-F instances running on servers  $s_{18}$ ,  $s_{19}$ , and  $s_{20}$ . In this case, the highly localized marked subspace in the attribute-value space for node C, in fact, is consistent with the actual source of the errors—a failing hardware network-interface controller in server  $s_8$ . Thus, when call-trace analysis reveals a subspace of the attribute-value space corresponding to a single node instance, the analysis strongly points to a single-server root cause. In more complex, but similar cases, relevant nodes and node instances are revealed by a decision-tree-like analysis which seeks the simplest explanation for partitioning a set of call traces into a first set of call traces that include the problematic node instances and a second set of call traces that either includes only non-problematic node instances or includes both the problematic node instances as well as additional node instances.

[0103] FIGS. 25A-D provide additional examples of identifying relevant dimensions with respect to problem-associated components within a distributed computing system. As shown in FIG. 25A, a simple distributed service-oriented application 2502 includes five types of service nodes: (1) a load-balancer node 2504; (2) an API-server node 2506; (3) a redis-cache node 2508; (4) a dbserver node 2510; and (5) a third-party DBMS node 2512. As with the previous examples, each of these service nodes includes multiple instances, and the service-node instances are associated with attribute values. There are two different types of call traces produced by service-request calls to the distributed service-oriented application as indicated by arrows in the distributed-service-oriented-application diagram 2502 and indicated by the call trace representations 2514 and 2516. Note that the different service nodes are represented by single-character abbreviations, or labels, shown below the disk-shaped representations of the nodes in the distributed-service-oriented-application diagram 2502.

[0104] FIG. 25B illustrates a first example of a dimensional analysis of a detected problem in the distributed service-oriented application discussed above with reference to FIG. 25A. In FIG. 25B, as with FIGS. 25C-D, discussed below, a portion of the attribute-value space associated with each service node is represented by a two-dimensional section, such as two-dimensional section 2520 shown associated with the redis-cache node 2508. In the two-dimensional section 2522 associated with the third-party-DBMS node 2524, all of the cells corresponding to a particular server are marked to indicate that the third-party-DBMS node instances associated with the particular server have been determined, by metric analysis, to be exhibiting some type of problem or failure. The remaining service nodes are all associated with two-dimensional sections of the attribute-value space in which the marked attribute values that occur in the call traces that include the problem instances of the third-party-DBMS node are distributed across both of the dimensions, revealing no particularly relevant pattern with respect to the problem-associated third-party-DBMS node instances. In this case, the relevant server-attribute dimension associated with the problem-associated third-party-DBMS node instances is indicative of a problem, such as an overloaded CPU, on a particular server.

[0105] FIG. 25C illustrates a second example of a dimensional analysis of a detected problems in the distributed service-oriented application discussed above with reference to FIG. 25A. In this example, numerous instances of the third-party-DBMS node have been determined to be exhibiting anomalous operational behavior via metric analysis. However, the shaded cells, such as cell 2530, in the two-dimensional section of the attribute-value space 2532 associated with the third-party-DBMS node are distributed across both dimensions, revealing no particular pattern or locality within the attribute-value space. When the recently collected call traces that include the problem-associated instances of the third-party-DBMS node are analyzed, and the attribute values of the other service-node instances that appear in these call traces are marked by crosshatching in the remaining two-dimensional sections associated with the other service nodes, the two-dimensional section 2534 associated with the dserver service node 2536 indicates that only version 3.1 dserver instances occur in the call traces. This is a strong indication that there is a problem with version 3.1 dserver instances that is the root cause of the observed third-party-DBMS-node instance failures. No such pattern is evident in the two-dimensional sections associated with the remaining service nodes. In this case, the root cause arises from generation of malformed SQL queries by the version 3.1 dserver instances.

[0106] FIG. 25D illustrates a third example of a dimensional analysis of a detected problems in the distributed service-oriented application discussed above with reference to FIG. 25A. In this example, a portion of the dserver service-node instances associated with a particular server have been identified as exhibiting anomalous operational behavior, as indicated by shading of cells 2548-2542. When the attribute values associated with other service-node instances that appear in the call traces that include the dserver service-node instances exhibiting anomalous operational behavior, instances of the third-party-DBMS node associated with a particular server, as indicated by the crosshatched cells 2544-2546 along a single server-attribute dimension, are observed. In this case, the observed pattern of relevant attribute values along the two server-attribute dimensions for instances of the dserver and for instances of the third-party-DBMS node indicate a problem involving the two servers corresponding to the two relevant server-attribute dimensions. In fact, in this case, the problem arises from a failing network connection between these two servers. Not all of the cells in each of the two relevant dimensions are marked, indicating that dserver service-node instances associated with the relevant server-attribute dimension are able to communicate with other third-party-DBMS-node instances and third-party-DBMS-node instances associated with the relevant server-attribute dimension in the two-dimensional section 2548 receive internal service requests from dserver service-node instances associated with servers other than the server corresponding to the relevant dimension in the two-dimensional section 2550.

[0107] In order to analyze metric-data, attribute-value data, and call-trace data, decision-tree-based analyses are used, as mentioned above. It is not necessary, in general, to construct an entire decision tree, nor is it necessary to even construct partial tree-like data structures. Instead, all of the relevant dimensions associated with all of the relevant service nodes may be considered, in turn, to determine

whether or not a small number of logical decision-tree nodes could be used to partition relevant call traces into call traces associated with some localized subregion of the attribute-value space associated with one or more service nodes of a distributed service-oriented application. This same technique can be extended to analyze other types of distributed-computing-system components, in addition to distributed service nodes. However, the current examples are based on distributed service nodes as examples of distributed-computer-system components because call-tracing services have been developed to trace service requests through a distributed service-oriented applications. Similar types of tracing services may be developed for other types of distributed-computer-system components, in which case the currently disclosed methods would be applicable to dimensional analysis with respect to the other types of distributed-computer-system components. A decision-tree-based analysis can be employed in order to determine whether a localized region of the attribute-value space of service nodes that appear in call traces that include problem-associated service-node instances can be found, such as the case discussed with reference to FIG. 25C, in which all of the version 3.1 instances of the dserver node, and only the version 3.1 instances of the dserver node, appear in the call traces that include the problem-associated third-party-DBMS-node instances. A decision-tree-based analysis can also be employed in the example discussed above with reference to FIGS. 23A-K, where an attribute-value-based partitioning was found for partitioning all of the recently collected call traces into call traces that include only the problematic service-node instances. The two types of decision-tree-based analyses are slightly different, and dimension-based analysis of collected data to find attribute dimensions related to detected problems may use both types of decision-tree based analyses as well as additional types of decision-tree based analyses. In all cases, the currently disclosed methods seek relatively simple explanations corresponding to locality of relevant-node-instance attributes within the attribute-value space associated with the service nodes and corresponding to only a few decision-tree nodes with relatively simple partitioning expressions, as further discussed below.

[0108] FIGS. 26A-B illustrate data structures and analytical approaches used in the control-flow diagrams provided in FIGS. 27A-F, discussed below, to illustrate decision-tree-based methods for identifying attribute dimensions relevant to observed anomalies in the operational behaviors of distributed-computer-system components. FIG. 26A shows a data structure that stores call traces combined with attribute values, including attribute values obtained directly from call traces as well as attribute values maintained by an attribute service, as discussed above. The traces data structure 2602 includes a full set of recently received call traces 2604, with each call trace represented by a row in the tabular data structure. The service nodes in each call trace are represented by higher-level columns 2606-2610, each of which contains multiple lower-level columns, each lower-level column representing the value for an attribute maintained for the service node. For example, higher-level column 2606 represents a first service node and the lower-level columns 2612 2613 and 2614 store values for attributes a1, a2, and a3 for the first service-oriented-application. FIG. 23H provides an example of a tabular data structure storing recently collected call traces. The column T-map 2615 contains

Boolean values indicating whether or not each call trace of the recently received call traces **2604** is to be considered during the current decision-tree-based analysis. Thus, this column is used to select the set of call traces to be used for a particular analysis. In the above-discussed examples, one such subset that is commonly used is the subset of call traces that include problem-associated service-node instances. Thus, as shown in diagram **2616** in FIG. **26A**, the T-map column is used to select the current traces **2618**, or current subset of the full set of traces, for an analysis. The column R **2620** is used to identify the relevant call traces for a decision-tree-based partitioning of the current call traces. For example, the relevant call traces may be call traces that include particular service-node instances identified as exhibiting anomalous operational behaviors. The decision-tree-based partitioning seeks to find several decision-tree nodes containing relatively simple partitioning expressions that will partition the current nodes into a set containing the relevant traces, and only the relevant traces, and another set that, depending on the particular type of decision-tree analysis, may contain only the non-relevant traces or may contain both relevant and non-relevant traces. As indicated by diagram **2622**, the Boolean values in the column R select a subset of the current traces **2624**, and a function is applied to those selected traces to produce a set of relevant target-node instances **2626**, such as the particular service-node instances identified as exhibiting anomalous operational behaviors. Thus, decision-tree-based partitioning attempts to partition all of the service-node instances associated with current traces into the set of relevant target-node instances **2626** and another set **2628** that includes non-relevant target-node instances as well as, in some cases, relevant target-node instances. Finally, the data structure includes a current\_node pointer **2630** and a target\_node pointer **2632**. The target\_node pointer points to the service node that contains instances considered to be target instances for partition **2626** and the current\_node pointer points to the service node associated with the attribute dimensions that are to be used in the decision-tree-based analysis in an attempt to partition the target-node instances. In certain cases, the current\_node pointer and the target\_node pointer may point to the same service node.

[0109] FIG. **26B** illustrates the decision-tree-based analysis used in currently disclosed methods. The analysis considers the attribute values associated with instances of the service node referenced by the current\_node pointer **2640**. The analysis attempts to build a small decision tree **2642** that can be used to partition the current traces into a set of relevant target-node instances **2644** and other sets **2645-2646** containing non-relevant target-node instances. In the case of an analysis where the current\_node pointer and the target\_node pointer point to the same service node, the relevant target-node instances may often occur in all of the current call traces and the non-relevant target-node-instance sets would be empty at the lowest level of the decision tree. Each node of the decision tree includes a Boolean expression, such as expressions **2646-2647** in decision-tree nodes **2648** and **2649**, respectively. A Boolean expression **2650** includes one or more terms, with multiple terms separated by Boolean OR operators. Each term indicates that a particular attribute  $a_i$  of the current node has a particular value, such as the attribute value  $a_{im}$ . The traces input to the node are partitioned by the node into traces for which the expression returns a TRUE result and traces for which the expres-

sion returns a FALSE result, as indicated by diagram **2652**. When the decision-tree-based analysis succeeds, the left-most leaf set of the decision tree **2654** contains all of the relevant target-node instances and only the relevant target-node instances. The goal of the analysis **2656** is to find a portion of a decision tree that generates the relevant target-node instances with minimal cost, where the cost **2658** is equal to the number of attribute values in all of the expressions along a path of nodes leading to the relevant target-node instances summed with the depth of the decision tree minus one. In other words, the analysis seeks the simplest explanation that partitions the current traces into a set of traces corresponding to the relevant target-node instances. The product result produced by the analysis **2660** is one or more decision-tree synopses indicating the cost of the decision tree, the number of attributes or nodes in the path of the relevant target-node instances, and the expressions in each of those nodes. These decision-tree synopses can be sorted by cost to produce an ordered set of likely relevant attribute dimensions related to a set of target service-node instances. There are many well-known decision-tree methods, including 1D3 and J48/C4.5. Many specific approaches to decision-tree analysis may be employed in the currently disclosed methods.

[0110] FIGS. **27A-IH** provide control-flow diagrams that illustrate one implementation of the decision-tree-based analysis used by currently disclosed methods and systems for determining attribute dimensions of the distributed-computer-system components relevant to particular anomalous operational behaviors observed for one or more distributed-computer-system components. FIGS. **27A-B** provides a control-flow diagram for a routine find\_node\_relative\_dimensions that processes call traces in the logical traces data structure **2602** described above with reference to FIG. **26A** to find a best decision tree, or portion of a decision tree, to partition target-node instances based on attribute values for the node referenced by current\_node. In step **2701**, the routine find\_node\_relative\_dimensions receives the traces data structure and a reference to a memory location for storing a result. In step **2702**, the local set variables relevant\_instances, remaining\_instances, current\_traces, and attributes are initialized to contain no entries. Set variables operate like mathematical sets, and contain only a single entry for any particular value. In addition, the cost field of the result referenced by the reference result is set to 0, a value indicating that the dimensional analysis has failed. In the for-loop of steps **2703-2706**, the attributes associated with the node referenced by current\_node are placed into the set attributes. In the for-loop of steps **2707-2715**, each trace in the traces data structure is considered, with t representing the index of a trace. Those traces indicated to be members of the current traces by the T-map are placed into the set variable current\_traces in step **2709**. In step **2710**, a function instance is used to obtain an identifier for the target-node instance corresponding to the currently considered trace. The function returns a non-instance-identifying value when the target-node instance does not appear in the current trace. The determined target-node-instance identifier, if it has a target-node instance-identifying value, is placed in the set variable remaining\_instances and, when the instance is indicated in the R column of the traces data structure to be a relevant target-node instance, as determined in step **2712**, the determined target-node-instance identifier is placed into the set variable relevant\_instances in step **2713**. Moving to

FIG. 27B, in a series of conditional steps 2716-2718, the routine `find_node_relative_dimensions` determines whether or not there is sufficient data in the traces data structure for dimensional analysis. For example, when there are no attributes associated with the current node, when the number of current traces is below a threshold value, or when the set variable `relevant_instances` is empty, indicating that there are no relevant target nodes for the analysis, routine `find_node_relative_dimensions` returns. Otherwise, in step 2719, routine `find_node_relative_dimensions` calls the routine `build_partial_D_tree` to attempt to logically generate a portion of the left-hand edge of a decision tree that would select the relevant target nodes and only the relevant target nodes from the current call traces.

[0111] FIGS. 27C-D provide control-flow diagrams for the routine `build_partial_D_tree`, called in step 2719 of FIG. 27B. In step 2720, the routine `build_partial_D_tree` receives the trace data structure 2602 along with the reference result, the set variables `relevant_instances`, `remaining_instances`, `current_traces` and attributes, a variable depth containing the currently considered level of the decision tree, a variable cost containing the current cost of the decision tree. In step 2721, local variable `best` is initialized to a large integer value, local variable `best_a` is initialized to contain no attribute, local variable `best_ct` is initialized to contain a large integer value, local variable `best_nxt_exp` is initialized to contain the empty string, and the local set variable `best_remaining` is initialized to the empty set. In the for-loop of steps 2722-2731, each attribute `a` in the set `attributes` is considered for being the attribute in a next node of the partial decision tree. In step 2723, a routine `partition_on_attribute` is called to logically create a node corresponding to the currently considered attribute `a`, returning the cost of the expression in the node `ct`, the expression for the node `nxt_exp`, and the set of target-node instances `remaining` that remain after the expression in the node and in any higher-level nodes are applied to the current traces. When the routine `partition_on_attribute` returns an empty set `remaining`, as determined in step 2724, the partial decision trees complete, and the dimensional analysis has identified a set of relevant dimensions to explain the relevant target nodes. In this case, in step 2725, values are entered into the `cost` and `num_attributes` fields of the result and the current node expression is entered into the subfield of the expressions field corresponding to the depth of the node generated by the routine `partition_on_attribute`. When the set `remaining` returned by the routine `partition_on_attribute` is equal to the set `remaining_instances`, as determined in step 2726, the routine `partition_on_attribute` failed to find an attribute that would further decrease the number of target-node instances, as a result of which control flows to step 2730, where the routine `build_partial_D_tree` determines whether to continue iterating the for-loop of steps 2722-2731. Otherwise, in step 2727, a total cost function is used to determine a cost metric for the node that would be associated with the currently considered attribute `a` and, when this cost metric is lower than the contents of the local variable `best`, as determined in step 2728, the parameters for the node that would be associated with the currently considered attribute are stored in the local variables in step 2729. Continuing in FIG. 27D, in a series of conditionals, the routine `build_partial_D_tree` determines whether or not to continue the dimensional analysis. When no attribute was found for association with a new node by the routine `partition_on_attribute`, as deter-

mined in step 2732, the analysis has failed and the routine `build_partial_D_tree` returns. In step 2733, the attribute `best_a` is removed from the set `attributes`. When the set `attributes` is not empty, as determined in step 2734, there is no point continuing the dimensional analysis and so the routine `build_partial_D_tree` returns. When the current depth of the decision tree is equal to a threshold value, as determined in step 2735, the partial decision tree is already too complex and costly to represent a valid relevant-dimension determination, and therefore the routine `build_partial_D_tree` returns. In other words, as the depth of the tree grows, the complexity of the decision-tree-analysis-generated explanation for the partitioning of the current traces into a set of traces corresponding to the relevant target-node instances increases, and a point may be reached where the explanation has no relevance to the higher-level dimensional analysis of observed anomalies. A more comprehensive determination that considers the entropy of the remaining partitioning task may be undertaken to determine when to short-circuit the dimensional analysis, in alternative implementations. Otherwise, in step 2736, the routine `build_partial_D_tree` is recursively called to attempt to generate an additional node along the left edge of the partial decision tree. When that call fails, as determined in step 2737, the routine `build_partial_D_tree` returns. Otherwise, in step 2738, the expression for the node created by the `build_partial_D_tree` is entered into the proper position within the subfield of the expressions field of the result.

[0112] FIGS. 27E-F provides a control-flow diagram for the routine `partition_on_attribute`, called in step 2723 of FIG. 27C. In step 2739, the routine `partition_on_attribute` receives the traces data structure, the set variables `relevant_instances`, `remaining_instances`, and `current_traces`, and the attribute `a`. In step 2740, a local set variable `val` is initialized to the empty set. In the for-loop of steps 2741-2744, all of the current traces are considered in order to determine the set of different values for attribute `a`, which are stored in set variable `val`. In step 2745, the routine `best_value` is called to further partition the target-node instances in the set variable `remaining_instances`, returning the left-hand resultant partition, `remaining`, for a decision-tree node based on a value `v` selected from the value stored in the set variable `vals`. When the set `remaining` is empty, as determined in step 2746, the node containing an expression including the attribute value `v` is sufficient for a partitioning that generates the relevant target-node instances, and therefore the routine `partition_on_attribute` returns, in step 2747, an expression for the node as well as a cost of 1 in the return value `ct`, when the set `remaining` is equal to the set `remaining_instances`, as determined in step 2748, the routine `best_value` failed to find a value that provided additional partitioning of the target-node instances in the set `remaining_instances`. In this case, the routine `partition_on_attribute` returns, with the failure detected in the calling routine `build_partial_D_tree`. Continuing in FIG. 27F, since the set `remaining` still includes target-node instances that need to be filtered, the value `v` is removed from the set `val` in step 2749 and the routine `best_value` is again called in step 2750. If another attribute value is found by the routine `best_value`, and if this attribute value further partitions the target-node instances of the set `remaining`, as determined in step 2751, then, in step 2752, the routine `partition_on_attribute` returns a node expression that includes both the previously identified attribute value in the attribute value determined in step 2750 as well as a cost

of 2. Otherwise, when the second call to the routine `best_value` did not provide a value that further partitioned the target-node instances, as determined in step 2751, an expression containing only the initial identified value, identified in step 2745, and a cost of 1 is returned in step 2753. In the implementation shown in FIGS. 27A-G, node expressions with more than two attribute values are not considered, since once more than two attribute values are needed to produce a partitioning, the likelihood that the attribute is a significant and relevant dimension is considered to be below a threshold probability. In other words, in the illustrated and described implementation, the dimensional analysis is looking for attribute dimensions with highly localized value subsets that might explain the observed problem-associated, or relevant target-node instances.

[0113] FIG. 27G provides a control-flow diagram for the routine `best_value`, called in step 2745 in FIG. 27E and in step 2750 in FIG. 27F. The routine `best_value` attempts to select a best attribute value from the attribute values in the set `val` for partitioning the target-node instances in the set `remaining_instances` to produce a resultant set as close as possible to the relevant target-node instances. In step 2754, the routine `best_value` receives the traces data structure, the sets `relevant_instances`, `remaining_instances`, `current_traces`, and `val`, and the currently considered attribute `a`. In step 2755, local variable `v` is set to a non-attribute-value value and local set `remaining` is set to contain the same target-node instances is contained in the set `remaining_instances`. In the outer for-loop of steps 2756-2778, each attribute value `iv` in the set `val` is considered. For each considered attribute value `iv`, the local set `rem` set to the empty set, in step 2757 and, in the for-loop of steps 2758-2764, a partitioning of the target-node instances in the set `remaining` is carried out based on currently considered attribute value `iv`. In the for-loop of steps 2758-2764, each trace in the current traces is considered. When the currently considered trace has a value for attribute `a` equal to the currently considered attribute value `iv`, as determined in step 2759, the instance `i` for the target-node instance contained in the currently considered trace is determined by a call to a function `instance`, in step 2760. The function `instance` returns a node identifier in the case that the target node does not appear in the currently considered trace. When the instance `i` is not contained in the set `remaining_instances`, as determined in step 2761, the for-loop of steps 2759-2764 is terminated, because the partitioning carried out by the for-loop of steps 2759-2064 should not add any non-relevant target-node instances to the left-hand partition produced by the decision-tree node that includes an expression containing the currently considered attribute value. Otherwise, the instance `i` is added to the set `rem`, in step 2762. Upon completion of the for-loop of steps 2759-2064, the routine `best_value` determines, in step 2065, whether the number of target-node instances in the set `rem` is less than the number of target-node instances in the set `remaining`. If so, the local variable `v` is set to the currently considered attribute value `iv` and the set `remaining` is set to contain the contents of the set `rem`, in step 2766, since the partitioning produced by the currently considered attribute value `iv` is better than that produced by any previously considered attribute values during execution of the for-loop of steps 2758-2064. At the completion of the for-loop of steps 2756-2778, all of the attribute values in the set `val` have been considered, and the routine `best_value` returns.

[0114] FIG. 27H provides an indication of how the above-described decision-tree-based dimensional analysis is incorporated into an overall dimensional analysis based on metric values, attribute values, and call traces. FIG. 27 H provides a control-flow diagram for a routine `find_relevant_dimensions`, which illustrates a family of approaches to the dimensional analysis disclosed in the current document. In step 2779, metric data is used to identify problem nodes and problem-node instances, as discussed above with reference to FIGS. 22A-B. In step 2780, attribute-value data and call-trace data are used, together, to generate collected call-trace-and-attribute-value data, such as the data stored in the traces data structure discussed above with reference to FIG. 26A. In step 2781, an array of results is allocated to hold results such as the result 2660 discussed above with reference to FIG. 26B. In the for-loop of steps 2782-2792, each identified problem node `p` it is considered. In step 2783, the column `R` of the traces data structure is set to identify traces that include problem-associated instances of the currently considered problem node `p`. In step 2784, the `T`-map column of the traces data structure is set to identify call traces that include the currently considered problem node `p`. In the inner for-loop of steps 2785-2790, each of the different nodes `n` in the current traces identified by the `T`-map column are considered. In step 2786, the currently considered node `n` and currently considered target node `p` are input to the routine `find_node_relevant_dimensions`, discussed above with reference to FIGS. 27A-F. When the routine `find_node_relevant_dimensions` produces a result with a cost greater than 0, as determined in step 2787, the result is added to the set `results` in step 2788. Thus, for each identified problem node, relevant attribute dimensions for the nodes in the call traces that include the problem node are identified in the nested for-loops of steps 2782-2792. As indicated by ellipses 2793, many other dimensional analyses may be carried out, by including considerations of larger sets of call traces, and by varying other parameters provided to the routine `find_node_relevant_dimensions`. Furthermore, other approaches to identifying relevant attribute dimensions, in addition to those embodied in the routine `find_node_relevant_dimensions`, may be employed in additional dimensional analyses. Finally, all of the results collected in the set `results` may be sorted by cost and then encoded for transmission to one or more recipients, in step 2794.

#### Currently Disclosed Clustering Methods and Systems

[0115] FIG. 28 illustrates a problem with applying the above-discuss dimensional analysis to very large sets of call traces. In many cases, and often at early stages of anomalous operational behaviors within distributed computer systems, only a small percentage of the collected call traces are relevant to, or contain information useful for identifying, an emerging anomalous operational behavior. As an emerging problem cascades within a distributed computer system, a generally larger, increasing percentage of the call traces becomes relevant, but even in the latter stages, only a fraction of the total collected call traces contain information relevant to the cascading anomalous operational behaviors. In FIG. 28, a large circular area 2802 represents the total collected call traces and smaller circular areas 2804 and 2806 represent increasingly smaller subsets of the total collected call traces. When the above-discussed decision-tree-based dimensional analysis is applied to the total col-



lected call traces, as represented by curved arrow **2808**, the resulting decision tree **2810** may be large and complex, since complex logic may be needed to differentiate the small fraction of relevant call traces from the much larger fraction of non-relevant call traces in the total set of collected call traces. It may even be possible, in certain cases, that the above-discussed decision-tree-based dimensional analysis may fail to provide a decision tree that fully partitions the relevant call traces from the total set of call traces. When the above-discussed decision-tree-based dimensional analysis is applied to the smaller subset **2804** of the collected call traces, as represented by curved arrow **2812**, it is often the case that the resulting decision tree **2814** may be more compact and less complex, since fewer non-relevant call traces may need to be filtered out during dimensional analysis. When the above-discussed decision-tree-based dimensional analysis is applied to the smallest subset **2806** of the collected call traces, as represented by curved arrow **2816**, the resulting decision tree **2818** may be even more compact and less complex. The complexity and size of the decision tree produced by dimensional analysis is often inversely proportional to the utility of the decision tree for identifying attribute dimensions relevant to anomalous operational behavior within the distributed computer system. However, simply selecting a small subset of the call traces to which to apply the above-discussed dimensional analysis does not provide a workable solution to this problem, since, as discussed above, call traces that initially appear to be non-relevant may, in fact, be necessary for identifying root causes of anomalous operational behaviors. A full set of call traces therefore generally needs to be analyzed, since it cannot be predicted, in advance of determining a root cause for an anomalous operational behavior or error condition, which subset of the collected call traces is relevant to identifying the root cause.

[0116] One approach to addressing the problem discussed in the preceding paragraph is to use a clustering method to partition the total set of collected call traces into smaller subsets of related call traces, each subset of related traces representing a particular trace type. The disclosed approach involves vectorization of call traces, selection of a first distance metric for call-trace vectors and a second distance metric for call-trace-vector clusters, clustering call-trace vectors using the selected distance metrics, and application of the above-discussed decision-tree-based dimensional analysis to each cluster of call traces. Each of these steps are next discussed with reference to illustrations.

[0117] FIG. 29 illustrates one approach to vectorizing call traces. Plot **2902** illustrates the time sequence of service calls that together implement a distributed-application entrypoint, with a horizontal time axis **2904** and a vertical call-depth axis **2906**. A call to the distributed-application entrypoint begins with execution of the first service call **B 2908**. This service call, in an example distributed application, is active from time  $t_0$  **2910**, when the entrypoint call is received by the distributed application, to time  $t_e$  **2912**, when the call to the distributed-application entrypoint finishes. Service B first calls service J **2914**, which twice calls service C **2916-2917**. Service B then calls service R **2918**, which calls service F **2920**. Service B next calls service G **2922**, which then calls service M **2924**, which, in turn, calls service A **2926**. Finally, service B calls service K **2928**. The attributes associated with each service instance that executes in order to carry out the entrypoint call are shown in the plot

in parentheses, such as attributes  $a_1$ ,  $a_2$ , and  $a_3$  **2930** associated with an instance of service B. A call trace is collected for the sequence of service calls, as discussed above, and can be represented as graph **2932**. The call trace, in one vectorization approach, is vectorized by generating a vector with elements corresponding to the unique service calls in the call trace and ordered according to a service-ordering method **2934**. Attribute values for the service calls are then included within expanded elements of an expanded-elements vector **2936**. In many implementations, a final binary vector **2938** corresponding to vector **2936** is generated. In alternative approaches, a final vector with real-valued or integer-valued elements may be instead generated. A binary final vector is assumed in much of the following discussion.

[0118] FIGS. 30A-C illustrate several approaches to generating a final vector from the expanded-elements vector **2936** shown in FIG. 29. In a first approach, shown in FIG. 30A, the final bit vector **3002** includes a bit for each possible service-call/attribute-value pair observed in a set of collected call traces. In FIG. 30A, the three attribute values **3004** recorded for the call to an instance of service B **3006** are shown, with each attribute value including a first index indicating the attribute and a second index indicating a particular value of the indicated attribute. The three observed attribute values **3004** are mapped to the particular bits **3008-3010** corresponding to the service-call/attribute-value pairs, and those bits are set to 1 while the remaining bits associated with the service B are set to 0. In this approach, had there been multiple calls to service B with different attribute values, then all of the attribute values observed in the multiple calls would have corresponding bits set to 1. Similar mappings of service-call/attribute-value pairs for the other called services produce a final binary vector for the call trace.

[0119] FIG. 30B illustrates an alternative approach to generating a final vector from the expanded-elements vector **2936** shown in FIG. 29. In this approach, an index is assigned to each possible combination of attribute values for each service, and the final bit vector **3020** includes a separate bit for each index. A table **3022** is shown in FIG. 30B that contains all possible attribute-value combinations for service B. Each row in the table represents a different possible combination of attribute values. The index of a row serves as a single-integer representation of a particular combination of attribute values. In this case, the set of attribute values for the instances of service B **3024** in call trace **2932** shown in FIG. 29 is mapped to row **3026** and table **3022**, and the index of that row is used to identify the bit **3028** in the final bit vector **3020** corresponding to the set of attribute values **3024**. That bit is set to 1 and all the other bits associated with service B are set to 0, when generating the final bit vector for call trace **2932**. Here again, had multiple calls been made to a particular service in a call trace, the bits in the final bit vector corresponding to the cumulative set of attribute values for the multiple calls would be set to 1.

[0120] FIG. 30C illustrates a third approach to generating a final vector from the expanded-elements vector **2936** shown in FIG. 29. In this approach, similar to the approach discussed with reference to FIG. 30B, each service-call/attribute-value-set pair is mapped to a particular element in the final vector **3030**. However, the final vector contains real values, rather than bit values. The real values represent a fraction of service calls in the call trace corresponding to a particular service-call/attribute-value-set pair. There are, of

course, many alternative possibilities for vectorizing call traces. In all cases, the vectorization process is designed to produce different vectors for different types of call traces so that, as discussed below, a metric can be devised to produce distances from pairs of vectors that reflect the degree of dissimilarity between the call traces represented by the vectors.

[0121] FIGS. 31A-D illustrates several different types of metrics that can be used to determine the distance between two vectors. FIG. 31A illustrates the Euclidean distance metric. Two three-dimensional vectors  $a$  and  $b$  3102-3103 are plotted as points 3104 and 3105, respectively, in a three-dimensional plot 3106. The Euclidean distance  $d_E$  3108 between the two vectors is equal to the magnitude of the vector obtained by subtracting one vector from the other, which can be computed 3110 as the square root of the squared sums of the differences between the coordinates of the two vectors. The Euclidean distance  $d_E$  is the common physical distance associated with a three-dimensional real-world spaces. The Euclidean distance  $d_E$  is generally real valued and can be computed for vectors with real-valued, integer-valued, and bit-valued elements. The Euclidean distance between vectors 3102 and 3103 is 6.

[0122] FIG. 31B illustrates the Jaccard distance metric. The Jaccard distance metric  $d_1$  is a set-based distance metric that produces a real value in the range  $[0, 1]$ . A bit vector can be considered to represent a set by considering the elements of the vector as possible members of the set and considering those elements with value 1 as the members of the set. Two bit vectors  $v_1$  3102 and  $v_2$  3104 are shown on the left-hand side of FIG. 31B. The function  $\text{count}()$  computes the number of 1-valued elements in a bit vector supplied as an argument to the function 3106-3107. The bitwise exclusive-OR operator generates vector 3110 from vectors  $v_1$  3102 and  $v_2$  3104. Each element in the resultant vector 3110 is the value of a binary XOR operation applied to the corresponding elements of the two vector operands. The bitwise AND operator generates vector 3112 from vectors  $v_1$  3102 and  $v_2$  3104. Each element in the resultant vector 3112 is the value of a binary AND operation applied to the corresponding elements of the two vector operands. When both vectors are 0, the Jaccard coefficient  $J$  is 0 (3114 in FIG. 31B). Otherwise, the coefficient  $J$  is equal to the number of elements in the intersection of the two sets represented by vectors  $v_1$  3102 and  $v_2$  3104 divided by the number of elements in the union 3116 of the two sets represented by vectors  $v_1$  and  $v_2$ , which can be calculated 3118, from bit vectors, using the above-described count function and bitwise logical operators. The Jaccard distance metric  $d_1$  is computed as  $1-J$  (3120 in FIG. 31B). When both vectors are identical, the Jaccard distance metric  $d_1$  is 0. When both vectors represent two sets without any common elements, the Jaccard distance metric  $d_1$  is 1. The Jaccard distance  $d_1$  between bit vectors  $v_1$  3102 and  $v_2$  3104 is  $2/3$ .

[0123] FIG. 31C illustrates the cosine-similarity distance metric  $d_{\cos}$ . FIG. 31C shows the same two vectors 3130-3131 shown as bit vectors  $v_1$  3102 and  $v_2$  3104 in FIG. 31B. The cosine of the angle between two vectors is equal to the dot product of the two vectors divided by the product of the length of the two vectors 3132. The cosine-similarity distance metric  $d_{\cos}$  is the cosine of the angle between two input vectors and is a real number in the range  $[0, 1]$ .

[0124] FIG. 31D illustrates the three different distance metrics discussed above with reference to FIGS. 31A-C. On

the left-hand side of FIG. 31D, the different metric distances between a diagonal vector and the other vectors with integral-valued elements in a unit cube are shown for unit cubes 3140-3142. Each vertex in the unit cube corresponds to a different vector with integer-valued elements. The diagonal body vector 3144 has coordinates  $(1, 1, 1)$ . The distance between this vector and itself is 0, as indicated by numeric labels 0 3146-3148. The distance between each of the other vectors and the diagonal body vector are shown next to the point corresponding to the other vectors. For example, the Euclidean distance  $d_E$  between the vector  $(0, 0, 0)$  and the vector  $(1, 1, 1)$  is  $\sqrt{3}$ . The value  $\sqrt{3}$  appears next to the point 3150 corresponding to vector  $(0, 0, 0)$ .

[0125] A unit cube 3152 is shown in the center of FIG. 31D, with each vertex assigned a numeric label, such as the numeric label "7" assigned to vertex 3154. The three matrices 3160-3162 show the distances between each pair of vertices in the unit cube. Matrix 3160 shows the Euclidean distances, matrix 3161 shows the Jaccard distances, and matrix 3162 shows the cosine-similarity distances. Comparison of the matrices reveals that they all have the same general form. There are only four different distances between vertices in the unit-cube example: (1) 0, or  $d_{min}$ , the minimum distance which is the distance between a vector and itself; (2)  $d_{max}$ , the distance between vectors corresponding to vertices connected by a body diagonal; (3)  $d_1$ , the distance between vectors corresponding to vectors connected by a face diagonal; and (4)  $d_s$ , the distance between vectors connected by an edge. Were the numeric values in the three matrices replaced by  $d_{min}$ ,  $d_{max}$ ,  $d_1$ , and  $d_s$ , they would be identical. The requirement for a distance metric is that the distance between a vector and itself is 0, as expressed by the equation 3164, and that the triangle inequality hold for all pairs of vectors, as expressed by equation 3166. As can be seen in table 3168, the numerical values and ratios between the numerical values for the unit-cube distances vary among the three different distance metrics. It is possible to define additional distance metrics as linear combinations of the Jaccard distance and one of the other metrics, as expressed by equation 3170. The above-discussed distance metrics, and other types of distance metrics, can be used during the clustering of call traces, discussed below.

[0126] FIG. 32 illustrates various different distance metrics for clusters. The three-dimensional plot 3202 in FIG. 32 shows two different clusters 3204 and 3206, each containing points, such as point 3208, corresponding to vectors. The two different clusters represent a partitioning of the entire set of points into two groups based on distance. Each point in a cluster is closer to the other points of the cluster than to any point in the external, different cluster. Clustering of vectors representing call traces represent a partitioning of the call traces into sets of related call traces. Clustering involves use of distance metrics that represent distances between clusters, and these cluster-distance metrics are based on vector-distance metrics, such as the vector-distance metrics discussed above with reference to FIGS. 31A-D. One cluster-distance metric,  $d_{min}$ , is the minimum distance between a pair of points, one point in the pair selected from the first cluster and the other point in the pair selected from the second cluster. Double-headed arrow 3210 represents the  $d_{min}$  distance between the two clusters shown in FIG. 32. Another cluster-distance metric,  $d_{max}$ , is the maximum distance between any two points selected from the two clusters.

Double-headed arrow **3212** shows the  $d_{max}$  distance between clusters **3204** and **3206**. Yet another cluster-distance metric,  $d_c$ , is the distance between the centers of the two clusters, represented by double-headed arrow **3214**. Any of these three distance metrics can be used for clustering. Various other cluster-distance metrics can also be used.

[**0127**] FIGS. **33A-E** illustrate one approach to clustering vectors within the class of clustering methods referred to as “agglomerative” or “bottom-up.” FIGS. **34A-B** show two versions of a dendrogram generated during the vector clustering illustrated in FIGS. **33A-E**. FIGS. **33A-E** show a two-dimensional clustering example and these figures are discussed, below, in parallel with FIG. **34A**.

[**0128**] A two-dimensional set of vectors, each vector represented by a point in a two-dimensional space or surface, is shown in rectangle **3302** in FIG. **33A**. Each point, such as point **3304**, represents a two-dimensional vector that can be alternatively represented by a set of coordinates  $(x, y)$ . The same set of vectors is shown in rectangle **3306**, with each vector-representing point associated with a lower-case-letter label. Two-dimensional vectors are used in this example because they are easy to incorporate in illustrations. Call-trace vectors normally are of much larger dimension, from tens to hundreds of elements. Clustering involves assigning each vector to its own, initial single-vector cluster and then iteratively merging the two closest-in-distance clusters to produce a merged cluster with a greater number of members than either of the two clusters from which the merged cluster is produced. In FIG. **33B**, distances between various different vector-representing points are shown. The single-vector clusters corresponding to vectors *a* and *w* are first two single-vector clusters to be merged. This initial merger is indicated by the small enclosing ellipse **3308**. The distance between these two vectors is 2.5, as shown by the numeric label associated with the line segment connecting them. Turning to FIG. **34A**, a first point representing the first cluster merger **3402** is placed at a vertical distance of 2.5 above the horizontal axis **3404** with curves drawn from this point to positions on the horizontal axis corresponding to vector *a* **3406** and vector *w* **3408**. Each of the vectors in the set of vectors is represented by a unique position along the horizontal axis of the dendrogram. The vertical axis **3410** of the dendrogram represents distances between clusters. Any of the cluster-distance metrics, discussed above, based on any of the vector-distance metrics, also discussed above, can be used for clustering.

[**0129**] As also shown in FIG. **33B**, the initial merger in the sequence of mergers carried out during clustering includes the merger of single-vector clusters containing vectors *v* and *j*, represented by ellipsis **3310**, vectors *k* and *t*, represented by ellipse **3312**, vectors *a* and *x*, represented by ellipse **3314**, vectors *i* and *z*, represented by ellipse **3316**, vectors *b* and *s*, represented by ellipse **3317**, and vectors *y* and *q*, represented by ellipse **3318**. In addition, the two-vector cluster represented by ellipse **3308** is merged with the single-vector cluster containing vector *u*, as represented by ellipse **3320**. The 8 mergers represented by ellipses in FIG. **33B** are represented by points **3402** and **3412-3418** in the dendrogram shown in FIG. **34A**. As shown in FIG. **33C**, a next merger, represented by ellipse **3322**, merges the two-vector cluster inscribed within ellipse **3310** with the single-vector cluster containing vector *l*. This merger is represented by point **3420** in the dendrogram shown in FIG. **34A**. Because the mergers are carried out in ascending distance order, the

points corresponding to the mergers occur further and further above the horizontal axis in the dendrogram. Additional mergers are represented in FIG. **33C** by ellipses **3324 3326** and **3328**. The clustering process continues to create larger and larger clusters, as shown in FIGS. **33 D-E**. The final point **3422** in the dendrogram shown in FIG. **34A** represents the merger of the cluster represented by ellipse **3336** and the cluster represented by ellipse **3338** in FIG. **33E**. FIG. **34B** shows an alternative representation of the dendrogram shown in FIG. **34A**, produced by rearranging the order of the vector positions along the horizontal axis. This is a classical representation of a dendrogram and clearly shows the sequence of cluster mergers illustrated in FIGS. **33B-E**.

[**0130**] FIGS. **35A-C** illustrates cluster selection. Following the clustering of the vectors in the example of FIGS. **33A-E** and generation of the dendrogram shown in FIG. **34B**, a group of clusters needs to be selected. The clustering process results in one single cluster represented by the highest point in the dendrogram, but that single cluster, of course, has no analytical value since it does not represent a partitioning of the vectors into related groups. Similarly, the single-vector clusters that represent the initial starting point for clustering have no analytical value, since they also fail to represent a partitioning of vectors into related groups. Instead, a set of clusters at some intermediate height above the horizontal axis in the dendrogram need to be selected as an optimal or near-optimal clustering of the vectors into related groups.

[**0131**] One approach to selecting an optimal clustering involves analysis of a cluster-distance-versus-clustering-sequence graph. This graph can be generated from the dendrogram. FIG. **35A** shows the cluster-distance-versus-clustering-sequence graph for the dendrogram shown in FIG. **34B**. The vertical axis **3502** represents cluster distance and the horizontal axis **3504** represents the sequence of cluster mergers generated during the clustering process. The graph starts at the origin **3506**. A first point on the graph **3508** corresponds to the initial merger of single-vector clusters containing vectors *a* and *w*, which were closest of all single-vector clusters, at a distance of 2.5. The next point **3510** represents merging of the single-vector clusters containing vectors *v* and *j*, at a distance of 4.5. These points are connected by straight-line segments to give the impression of a continuous curve, but the curve is, in fact, discrete. The slope of the curve is relatively shallow up to the point **3512** representing the 21<sup>st</sup> cluster merger. The slope then greatly steepens. Point **3512** is thus the most prominent knee or elbow of the curve. In one approach to finding an optimal clustering, a clustering distance just above the prominent knee point, in the example of FIGS. **33A-35A** at a height of 20 above the horizontal axis, is chosen as the cutoff cluster distance. Then, as shown in FIG. **35B**, a horizontal line at the cutoff distance from the horizontal axis **3516** is drawn across the dendrogram. Any vertical lines passing through this horizontal line are followed back to the closest merger point, and the clusters represented by these merger points are selected as an optimal clustering. In the current case, the merger points **3520-3524** are associated with upper-case-letter symbols A-E corresponding to the vector clusters A-E **3530-3534**, respectively, shown in FIG. **35C**.

[**0132**] FIG. **36** illustrates the cophenetic correlation. The cophenetic correlation provides a numerical indication of how well the clustering distances produced during a clustering of vectors correspond to the distances between the

vectors. A set of  $N$  vectors **3602** is shown at the top of FIG. **36**. The distance  $d$  between a pair of the vectors **3604** is one of the above-discussed metric distances. The clustering distance between the two vectors, or dendrogram distance  $dd$ , is the distance **3606** between the highest level, in the dendrogram, of a merger path that connects the two vectors. An average distance  $\bar{d}$  and an average dendrogram difference  $\overline{dd}$  can be computed from the distances and dendrogram distances for all pairs of vectors, as indicated by expressions **3608** and **3610**, respectively. Finally, the cophenetic coefficient  $c$  is computed as indicated by expression **3612**. It is the ratio of the sum of the products of distance-displacements and dendrogram-distance displacements for all possible vector pairs to the product of the sums of the squared distance displacements and dendrogram-distance displacements for all possible vector pairs. The cophenetic coefficient is a real value in the range  $[0, 1]$ . The closer the cophenetic coefficient to 1, the closer the vector distances are to the dendrogram distances for the vector pairs. Thus, when the cophenetic coefficient has a value greater than a threshold value, the clustering can be considered to be a faithful clustering based on underlying vector differences.

**[0133]** FIGS. **37A-D** provide control-flow diagrams for a routine “trace types,” and additional routines called by the routine “trace types,” that together partition a set of call traces into a number of subsets of related traces, each subset representing a different trace type. FIG. **37A** provides a control-flow diagram for the routine “trace types.” In step **3702**, the routine “trace types” receives a references to a set of call traces  $T$ , a set of cluster-distance metrics  $M$ , a set of vectorization methods  $V$ , and references to memory locations for storing a set of vectors  $U$ , a set of clusters  $C$ , and a dendrogram  $D$ . In an outer for-loop of steps **3703-3713**, each vectorization method  $v$  in the set of vectorization methods  $V$  is considered. In an inner for-loop of steps **3705-3711**, each cluster-distance metric  $m$  in the set of cluster-distance metrics  $M$  is considered. In step **3704**, the call traces in the set of call traces  $T$  are vectorized to produce a set of call-trace vectors  $U$  using the currently considered vectorization method  $v$ . In step **3706**, the call-trace vectors  $U$  are clustered using the currently considered cluster-distance metric  $m$  from the set of cluster-distance metrics  $M$  to produce a set of clusters stored in memory location  $C$  and a corresponding dendrogram stored in memory location  $D$ . In step **3707**, a routine “verify” is called to determine whether or not the current clustering meets various clustering requirements, discussed below. If so, the routine “verify” returns the Boolean value TRUE along with a final clustering in memory location  $C$  and, otherwise, the routine “verify” returns the Boolean value FALSE. When the routine “verify” returns the Boolean value TRUE, as determined in step **3708**, the routine “trace types” returns, in step **3709**, the value TRUE, with the clustering stored in the memory location  $C$ . Otherwise, when there is another clustering-distance metric in the set of clustering-distance metrics  $M$  to try, as determined in step **3710**, a next clustering-distance metric  $m$  is retrieved from the set  $M$  and control returns to step **3706**, for a next iteration of the inner for-loop of steps **3705-3711**. Otherwise, when there is another vectorization method  $v$  in the set of vectorization methods  $V$  to try, as determined in step **3712**, a next vectorization method  $v$  is retrieved from the set  $V$  and control returns to step **3704** for a next iteration of the outer for-loop of steps **3703-3711**. When all possible vectorization methods and cluster-dis-

tance metrics have been tried in an attempt to produce a satisfactory clustering, but no satisfactory clustering is obtained, the routine “trace types” returns the value FALSE in step **3714**.

**[0134]** FIG. **37B** provides a control-flow diagram for the routine “cluster,” called in step **3706** of FIG. **37A**. In step **3715**, the routine “cluster” receives references to the set of vectors  $U$ , memory locations  $C$  and  $D$ , and a cluster-distance metric  $m$ . In step **3716**, the routine “cluster” clears the memory buffers referenced by  $C$  and  $D$ . In the for-loop of steps **3717-3720**, a new cluster is created for each vector  $u$  in the set of vectors  $U$  and added to the set of clusters stored in the memory referenced by  $C$ . Each new single-vector cluster  $c$  is marked as “unclustered” and the dendrogram stored in the memory location referenced by  $D$  is updated to include a point corresponding to each single-vector cluster  $c$ . Then, in each iteration of the while-loop of steps **3721-3728**, the closest pair of unclustered clusters is merged into a new cluster, in steps **3722-3723**, and each cluster of the pair is marked as “clustered.” When all of the current clusters are marked as “clustered,” as determined in step **3724**, the new cluster is marked as “clustered.” in step **3725**. Otherwise, the new cluster is marked as “unclustered,” in step **3726**. The dendrogram is updated to include information about the new cluster in step **3727**. The while-loop of steps **3721-3728** continues until there are no more unclustered clusters in  $C$ .

**[0135]** FIG. **37C-D** provide control-flow diagrams for the routine “verify,” called in step **3707** of FIG. **37A**. In step **3730**, the routine “verify” receives references to memory locations  $C$  and  $D$ , the set of vectors  $U$ , and the cluster-distance metric  $m$  and the vectorization-method  $v$ . In step **3732**, the routine “verify” computes the cophenetic coefficient for the clustering, as discussed above with reference to FIG. **36**. When the computed cophenetic coefficient has a value less than a first threshold value, as determined in step **3733**, the routine “verify” returns the Boolean value FALSE to indicate that the clustering in the memory location  $C$  does not adequately reflect the pairwise call-trace-vector distances. In step **3734**, the routine “verify” determines a provisional optimal clustering  $P$  using the cluster-distance-versus-clustering-sequence-graph-based method discussed above with reference to FIGS. **35A-C**.

**[0136]** The sparsity of a bit vector is the percentage of bits with the value 0 in the vector. Because the bit vectors representing call traces include bits for each possible attribute value or combination of attribute values for all of the service calls related to a distributed application, the call-trace bit vectors tend to be quite sparse. Following partitioning of the set of call traces into subsets of related call traces, via clustering, a re-vectorization of the call traces in each subset should produce vectors that are significantly less sparse than the original call-trace vectors, since the related call traces would be expected to have fewer different attribute values and/or attribute-value combinations. In step **3735**, the routine “verify” determines an average sparsity  $S$  for the original call-trace vectors in the set  $U$ . In addition, local variables  $R$  and  $num$  are set to 0. In the for-loop of steps **3736-3739**, the vectors in each cluster in the provisional clustering  $P$  are re-vectorized and the sparsities of the groups of re-vectorized vectors are accumulated in local variable  $R$ . Local variable  $num$  is incremented to count the number of clusters in the provisional clustering. Following the completion of the for-loop of steps **3736-3739**, local variable  $R$  is divided by local variable  $num$  to produce an

average sparsity for the re-vectorized call traces, in step 3740. When the ratio of R to S is greater than or equal to a second threshold, as determined in step 3741, the routine “verify” returns the Boolean value FALSE, in step 3742, because the clustering has not substantially reduced sparsity of the call-trace vectors and is therefore judged to be ineffective.

[0137] Turning to FIG. 37D, in step 3746, the routine “verify” sets a local variable numIter to 0, sets local set variables lowQ and lowV to the empty set, and sets local variables lq and lv to 0. In the for-loop of steps 3747-3754, each cluster c in the provisional clustering P is considered. In step 3748, local variable n is set to the size of the currently considered cluster and local variable r is set to the percent of the call traces in the currently considered cluster that are considered relevant to an error or other anomalous operational behavior that is being analyzed. When n is less than a third threshold, as determined in step 3749, the currently considered cluster is deemed to be too small for statistical purposes and is therefore entered into the set low V, in step 3750. Otherwise, when the percentage of relevant call traces in the currently considered cluster is less than a fourth threshold or greater than a fifth threshold, the currently considered cluster is considered to have low quality, and is therefore placed in the set lowQ, in step 3752. When the for-loop of steps 3747-3754 completes, and when no clusters were found to be too small or of low-quality, as determined in step 3755, the current provisional clustering is stored in the memory location referenced by C, in step 3756, and the routine “verify” returns the value TRUE. Otherwise, when the number of iterations stored in local variable numIter is greater than or equal to a sixth threshold, as determined in step 3758, the routine “verify” returns the value FALSE, since the clustering is considered to be ineffective. Otherwise, in step 3759, the provisional clustering is adjusted to increase the size of low-volume clusters and to improve the distributions of relevant and non-relevant call traces in the clusters. The adjustments may involve merging clusters, redistributing call traces between clusters, and other such adjustments.

[0138] FIG. 38 summarizes the currently disclosed clustering method for partitioning a set of call traces into subsets for dimensional analysis. The large disk representing the full set of call traces 3802 is partitioned by clustering into three subsets 3804-3806. Dimensional analysis is applied to each subset of call traces to produce relatively concise decision trees 3809-3811. Each decision tree can then be analyzed in order to ascertain the attribute dimensions relevant to a particular type of error in, or anomalous operational behavior of a distributed computer system. This approach solves the problem associated with applying dimensional analysis to a large set of collected call traces, discussed above with reference to FIG. 28, while nonetheless analyzing all of the original call traces. The small, relatively simple decision trees generally produced by this method provide greater explanatory power than an overly complex and large decision tree that may instead be produced by applying dimensional analysis to the full set of call traces. Moreover, in those cases in which dimensional analysis of the full set of call traces does not produce a usable decision tree, the currently disclosed clustering method may provide decision trees that can be used to identify relevant attribute dimensions.

[0139] The present invention has been described in terms of particular embodiments, it is not intended that the invention be limited to these embodiments. Modifications within the spirit of the invention will be apparent to those skilled in the art. For example, any of many different implementations can be obtained by varying various design and implementation parameters, including modular organization, control structures, data structures, hardware, operating system, and virtualization layers, and other such design and implementation parameters. As discussed above, there are many different types of cluster-distance and vector-distance metrics that can be employed during clustering. There are, in addition, a variety of different approaches to verifying clustering integrity, in addition to the cophenetic correlation coefficient. Clustering methods other than the above-described agglomerative method may also be used. Vectorization methods other than the above-described methods can also be employed.

1. A system that determines attribute dimensions correlated with anomalous operational behaviors of components of a distributed computer system, the system comprising:

one or more processors;

one or more memories; and

computer instruction, stored in one or more of the memories that, when executed by one or more of the processors, control the system to

collect metric data,

identify components of the distributed computer system which exhibit anomalous operational behaviors using the collected metric data,

access recently collected call traces from a call-tracing service,

access attribute values for components of the distributed computer system,

cluster the collected call traces into multiple subsets of related call traces, each representing a different trace type,

apply decision-tree-based analysis to each trace type to determine attribute dimensions of component types correlated with the identified components which exhibit anomalous operational behaviors, and

transmit the determined attribute dimensions to a computational entity to facilitate amelioration of the detected anomalous operational behaviors.

2. The system of claim 1 wherein components of the distributed computer system are selected from among:

a distributed service-oriented application;

service nodes of the distributed service-oriented application;

service instances of the service nodes of the distributed service-oriented application;

servers;

mass-storage devices and appliances; and

networking components.

3. The system of claim 1 wherein the metric data comprises a series of timestamped metric values associated with each of multiple metrics, each metric associated with a component or component type of the distributed computer system.

4. The system of claim 1 wherein the call traces each encodes a series of component types related to execution of a requested task or service.

5. The system of claim 4 wherein the call traces each encodes a series of service calls to service nodes within a

distributed service-oriented application related to a service call made by a remote client to the distributed service-oriented application.

6. The system of claim 1 wherein attribute values for components of the distributed computer system are points within an attribute-value space, for which attributes are dimensions, that is associated with the component type of the components.

7. The system of claim 6 wherein component attribute values are collected from one or more of an attribute-value store and call traces that include component types of the components of the distributed computer system which exhibit anomalous operational behaviors.

8. The system of claim 7 wherein the decision-tree-based analyses identify attribute dimensions of component types in which component attribute values are localized, rather than distributed across the dimensions.

9. The system of claim 8 wherein the decision-tree-based analyses determine attributes and attributes values that partition the collected call traces into a subset that contains call traces that include components of the distributed computer system, and only call traces that include components of the distributed computer system which exhibit anomalous operational behaviors, and one or more additional subsets.

10. The system of claim 1 wherein the collected call traces are clustered into multiple trace types by:

- vectorizing the call traces to generate an initial set of call-trace vectors;
- clustering the call-trace vectors;
- choosing a provisional set of clusters; and
- verifying the provisional set of clusters.

11. The system of claim 10 a call trace is vectorized by:

- identifying the unique service calls in the call trace;
- sorting the identified service calls to produce an ordered set of call traces;

- for each service call in the ordered set of call traces,
  - collecting the attribute values for the service-call instances invoked during execution of the service entrypoint represented by the call trace; and
- mapping the ordered set of call traces and collected attributes to a call-trace vector.

12. The system of claim 11 wherein the call-trace vector is a bit vector; and

- a unique bit in the call-trace vector corresponds to each different collected attribute-value/service-call pair.

13. The system of claim 11 wherein the call-trace vector is a bit vector; and

- a unique bit in the call-trace vector corresponds to each different attribute-value-combination/service-call pair.

14. The system of claim 10 wherein the set of call-trace vectors is clustered by:

- initially assigning each call-trace vector to a unique single-vector cluster; and

- iteratively merging a closest pair of clusters into a new cluster, where the distance between pairs of clusters is determined using a cluster-distance metric.

15. The system of claim 10 wherein a provisional set of clusters is chosen by:

- selecting a cut-off clustering distance at a clustering distance greater than the clustering distance of the prominent knee of a cluster-distance-versus-clustering-sequence graph; and

- selecting, as the provisional set of clusters, clusters formed from pairs of clusters closer than the cut-off

clustering distance that were subsequently merged from pairs of clusters further from one another than the cut-off clustering distance.

16. The system of claim 10 wherein the provisional set of clusters is verified by:

- calculating a cophenetic correlation coefficient for the clustering of call-trace vectors and determining that the cophenetic correlation coefficient is greater than a first threshold value;

- determining that a ratio of the average sparsity of the call-trace vectors produced by re-vectorizing the call traces in each cluster of the provisional set of clusters to the sparsity of the initial set of call-trace vectors is less than a second threshold;

- determining the number of call-trace vectors in each cluster of the provisional set of clusters;

- determining the percentage of relevant call-trace vectors specified to be relevant in each cluster of the provisional set of clusters;

- when the number of call-trace vectors in any of the clusters of the provisional set of clusters is less than a third threshold value or the percentage of relevant call traces in any of the clusters of the provisional set of clusters is less than a fourth threshold or greater than a fifth threshold, determining that the provisional set of clusters can be adjusted to produce an adjusted set of clusters that does not include any clusters with a percentage of relevant call traces less than the fourth threshold or greater than the fifth threshold and that does not include any clusters with a number of call-trace vectors less than the third threshold value.

17. A method that identifies attribute dimensions correlated with anomalous operational behaviors of components of a distributed computer system, the method comprising:

- collecting metric data comprising a series of timestamped metric values associated with each of multiple metrics, each metric associated with a component or component type of the distributed computer system;

- identifying components of the distributed computer system which exhibit anomalous operational behaviors using the collected metric data;

- accessing recently collected call traces from a call-tracing service;

- accessing attribute values for components of the distributed computer system;

- clustering the collected call traces into multiple subsets of related call traces, each representing a different trace type,

- applying decision-tree-based analyses to each trace type to determine attribute dimensions of component types correlated with the identified components which exhibit anomalous operational behaviors.

18. The method of claim 17 wherein the collected call traces are clustered into multiple trace types by:

- vectorizing the call traces to generate an initial set of call-trace vectors;

- clustering the call-trace vectors;

- choosing a provisional set of clusters; and

- verifying the provisional set of clusters.

19. A physical data-storage device that stores computer instructions that, when executed by one or more processors of a system that includes one or more memories and one or more mass-storage devices, controls the system to identify

attribute dimensions correlated with anomalous operational behaviors of components of a distributed computer system by:

- collecting metric data comprising a series of timestamped metric values associated with each of multiple metrics, each metric associated with a component or component type of the distributed computer system;
- identifying components of the distributed computer system which exhibit anomalous operational behaviors using the collected metric data;
- accessing recently collected call traces from a call-tracing service;
- accessing attribute values for components of the distributed computer system;
- clustering the collected call traces into multiple subsets of related call traces,
- applying decision-tree-based analyses to each subset of related call traces to determine attribute dimensions of component types correlated with the identified components which exhibit anomalous operational behaviors.

**20.** The physical data-storage device of claim **19** wherein a subset of the collected call traces are clustered into multiple subsets of related call traces by:

- vectorizing the call traces to generate an initial set of call-trace vectors;
- clustering the call-trace vectors;
- choosing a provisional set of clusters; and
- verifying the provisional set of clusters.

\* \* \* \* \*